

# BENT AXIS HYDRAULIC MOTORS

**FIXED DISPLACEMENT**

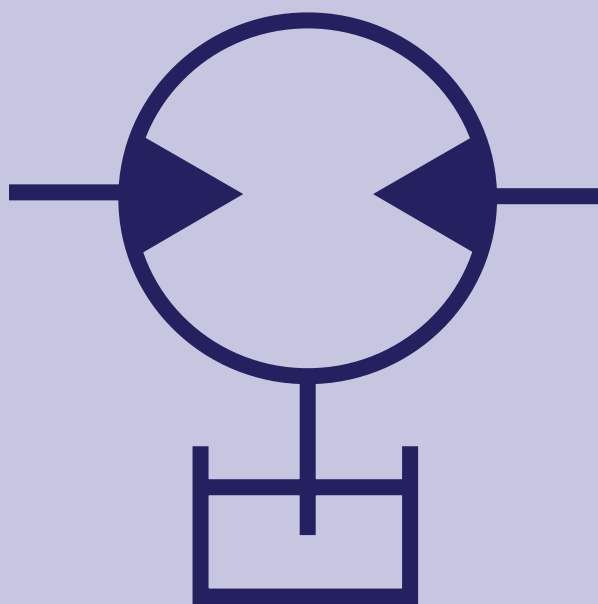

*make it simple*

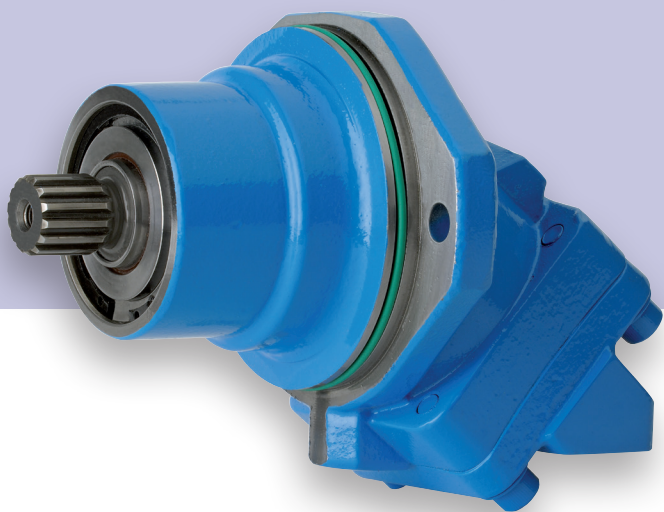
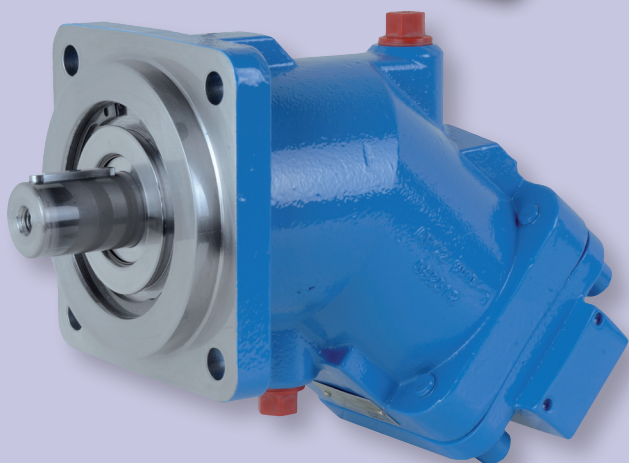
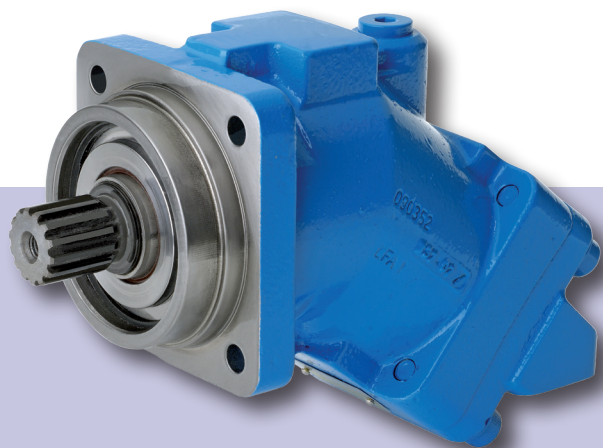

BENT AXIS  
HYDRAULIC MOTORS

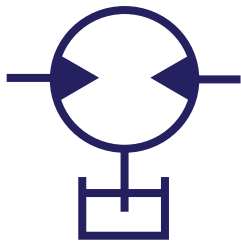

Applications and efficiency .....	4
Definition and advantages .....	5
Operating conditions .....	6
Determination / calculating the right motor .....	9

### M series

Range and characteristics of M series motors .....	11
Order code system of M series motors .....	13
Dimensions M 5 to M 180 .....	14

### MA series

Range and characteristics of MA series motors .....	28
Order code system of MA series motors .....	30
Dimensions MA 10 to 250 .....	31

### MSI series

Range and characteristics of MSI series motors .....	46
Order code system of MSI series motors .....	47
Dimensions MSI 28 to 180 .....	48

### Options | Accessories

Speed sensor .....	60
Flushing valve .....	61
Drainless motor .....	62

Other product lines .....	64
---------------------------	----

## M

- Displacement 5 cc/rev - CETOP
- Displacements from 12 to 180 cc/rev - ISO
- For fixed and mobile applications

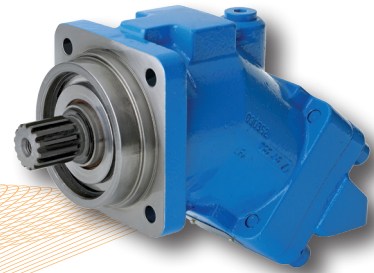

M series

## MA

- SAE
- Displacements from 10 to 250 cc/rev
- For fixed and mobile applications

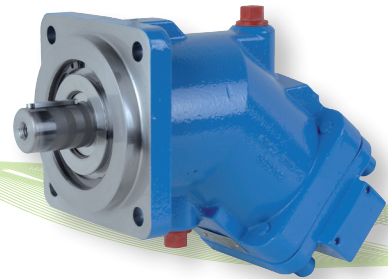

MA series

## MSI

- ISO - semi-integrated
- Displacements from 28 to 180 cc/rev
- For applications mounted on a planetary gearbox

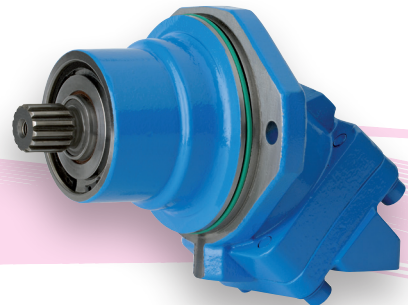

MSI series

## Options

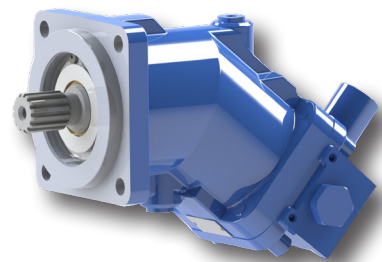

Options  
Accessories

### ► Main applications

Typical applications are those requiring high torque within a small size.

The hydraulic motor is essential for rotations where:

- Mechanical solutions are complex or even impossible.
- Electrical or pneumatic power sources are not available.
- Environments are dangerous (i.e. risk of explosion or extreme temperatures).

### ► Examples of use

- Mowers: drive of grass cutting blade, where mechanical solution would be too complicated or impossible.
- Blowers: compressor drive.
- Wheel drive of undercarriages for construction equipment (motor installed on planetary gearbox).
- Industrial of marine winch drive.
- Fan drives...

## EFFICIENCY OF M / MA / MSI SERIES MOTORS

N motor = 1000 rpm

ISO46 fluid at 77° F (25°C)

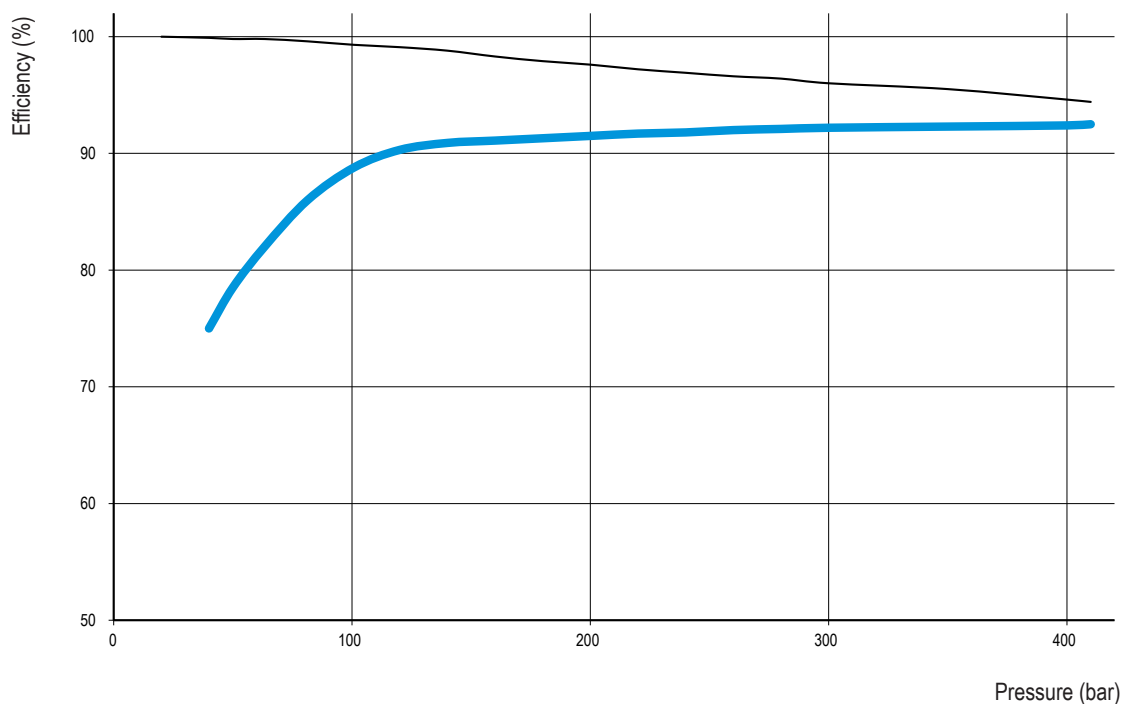

— Global efficiency  
 — Volumetric efficiency

This graph is given as an indication only.  
 For further information, please contact our Technical Service.

## ► Definition of function

Hydraulic motors transform hydraulic flow into rotating speed and hydraulic pressure into mechanical torque.

Motor rotating speed is proportional to the flow which is supplied to it. Torque produced is proportional to the hydraulic pressure the motor receives.



## ► Advantages of LEDUC motors

High quality materials and workmanship. The design choices highlighted below ensure the remarkable reliability and long service life of LEDUC motors.

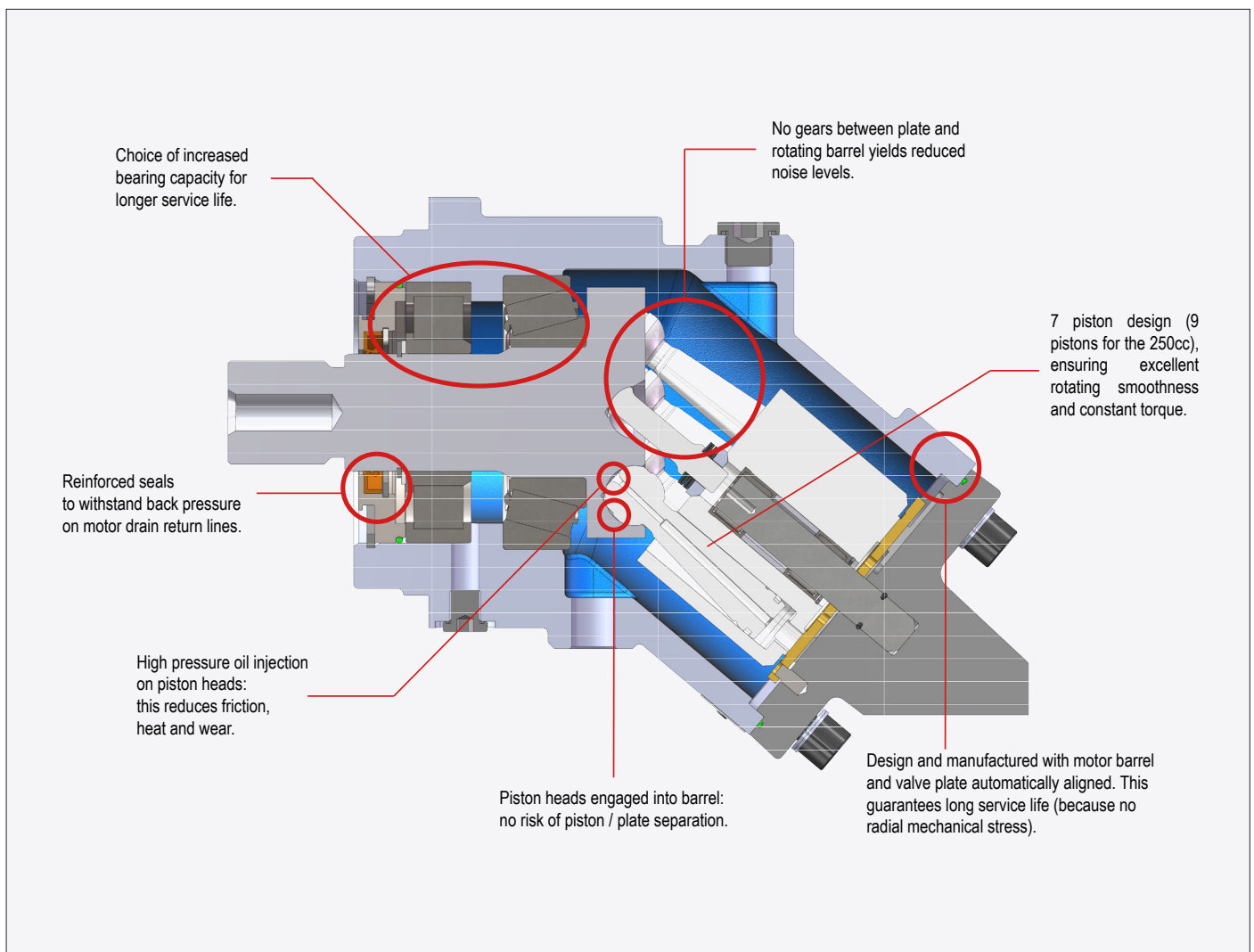

## ► Preparation of the motor

Before starting up, the hydraulic motors must be thoroughly lubricated with oil.

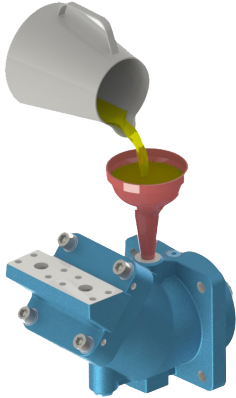

## ► The fluid

LEDUC motors are designed for use with mineral based hydraulic fluid such as HLVP. Using other fluids is possible but may require a modified motor.

Please contact us with details of fluid.

The fluid temperature within the motor must not exceed 90°C.

Recommended viscosity:

- Ideally: between 15 and 400 cSt;
- Maximum range: between 5 and 1600 cSt.

Fluid viscosities as a function of temperature

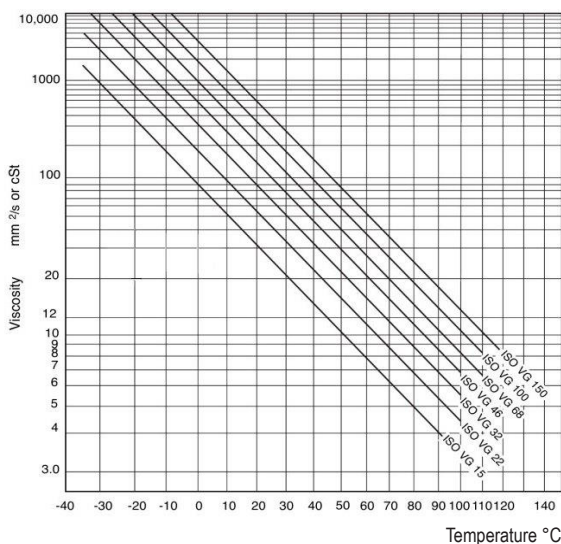

## ► Filtration of the hydraulic fluid

The service life of the motors depends greatly on the quality and the cleanliness of the hydraulic fluid.

We recommend minimum cleanliness as follows:

- NAS 1638 class 9,
- SAE class 6,
- ISO/DIS 4406 class 20/18/15.

For fluids at very high temperatures 194 to 239 °F (90 to 115 °C), we recommend a minimum cleanliness class of 19/17/14 according to ISO 4406.

## ► Rotating speeds

Minimum rotating speed to obtain continuous rotation is 200 rpm (however, in certain conditions, the motor can run at speeds as low as 50 rpm). Maximum rotating speed is given for each model of motor.

## ► Installation positions

LEDUC motors are made to operate in all positions (see details on page 7).

## ► Operating temperatures

- As standard, LEDUC motors are fitted with FKM seals (Viton®). Operating temperatures: from -13 to 239 °F (-25 to 115 °C).
- As an option, HYDRO LEDUC proposes NBR seals, for operating temperatures from -40 to 176°F (-40 to 80°C).

## ► Direction of rotation

The motors rotate clockwise or counter-clockwise depending on the direction of hydraulic flow entering the motor.

**Clockwise rotation (CW)**

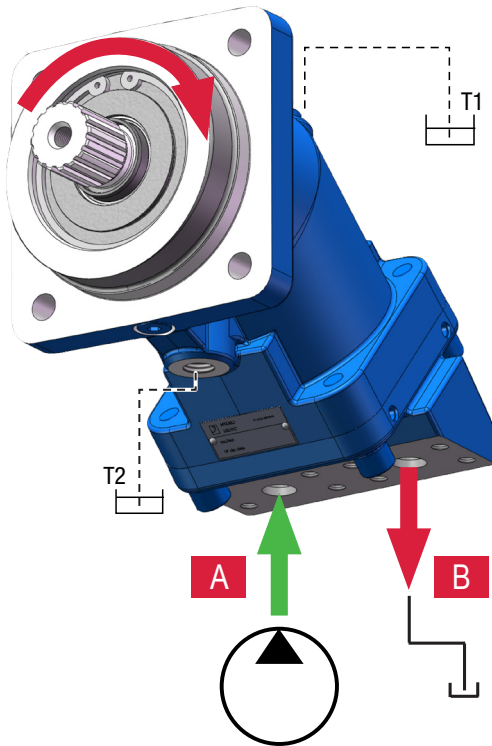

**Counter-clockwise rotation (CCW)**

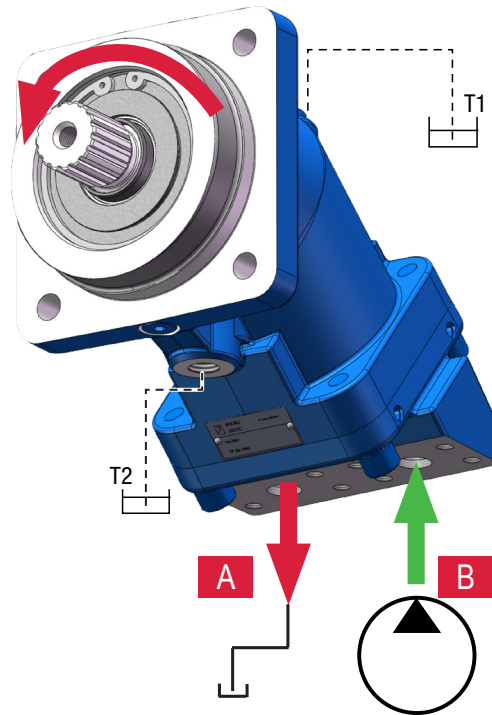

## ► Drain pressure

It is essential to drain the motor, T1 or T2, to avoid excessive pressures on the shaft seal. Maximum acceptable internal pressure depends on motor rotating speed.

However, following these guidelines will avoid problems during operation:

- Maximum internal pressure (int P) regardless of rotating speed (continuous): 4 bar;
- Maximum internal pressure (int P) regardless of rotating speed (peak): 5.5 bar;
- Minimum pressure in the motor housing: must be greater than ambient (external) pressure (ext P).

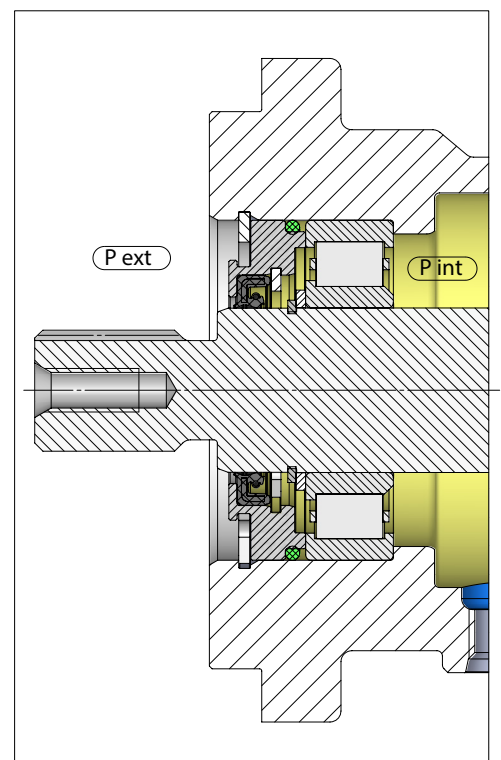

## ► Optimizing Motor Lifespan

In the case of radial force on the motor shaft, maintaining its orientation (as shown in the diagrams below) improves the motor's lifespan.

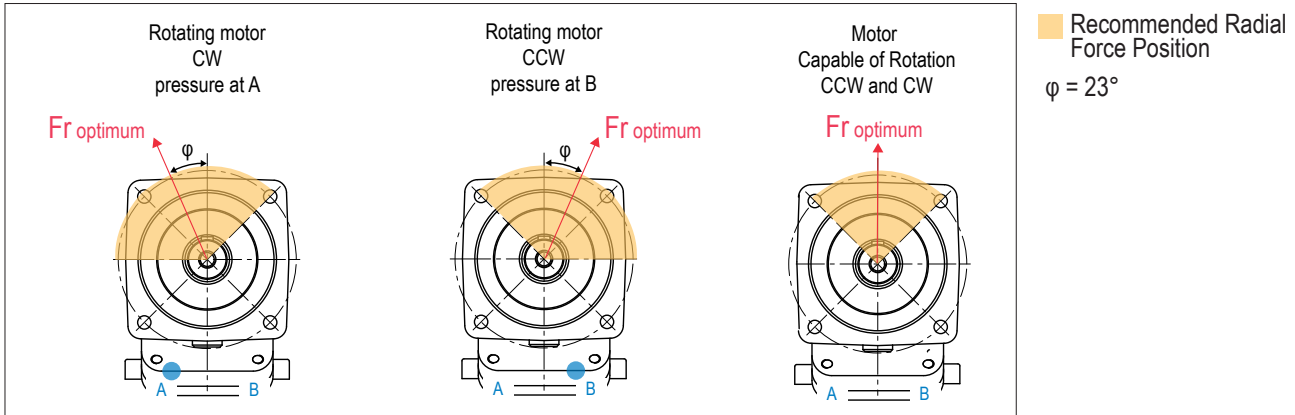

## ► Motor Mounting Positions

LEDUC motors can be used in any mounting position. When in the 'shaft up' position, ensure that the motor housing is completely filled with fluid (for M series motors, purge the air through connection T3).

T3 port is only available in the M series (except for M25 to M41).

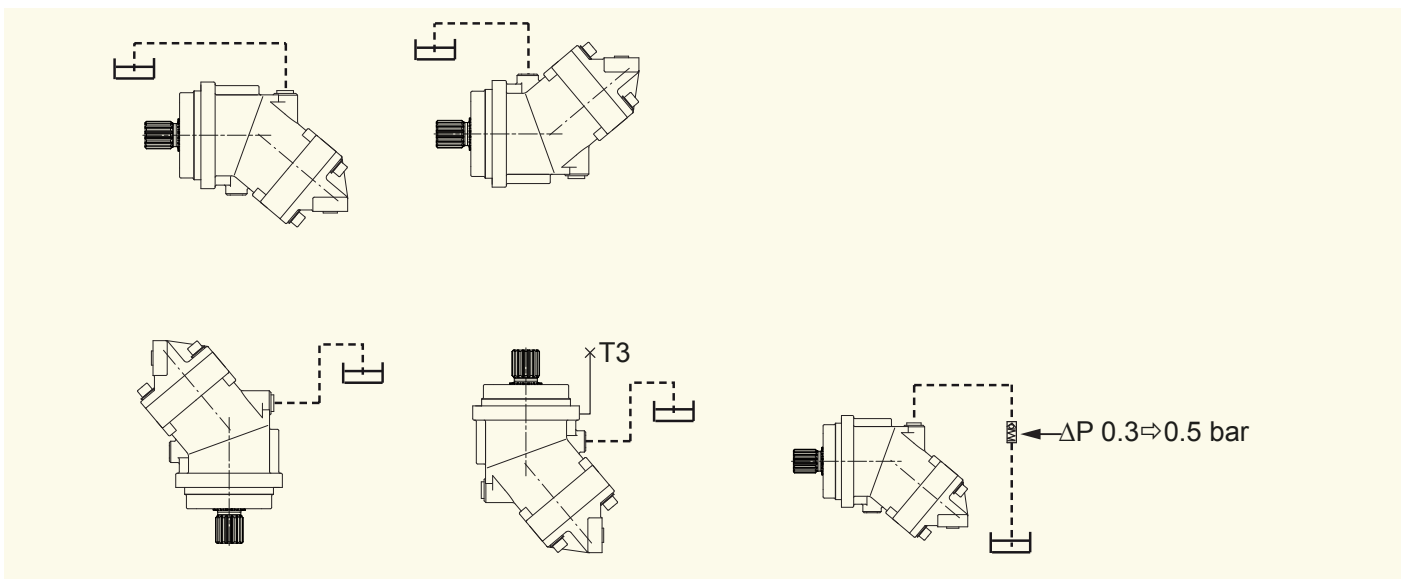

In all cases where the installation level (H) of the motor is positioned higher than the return reservoir of the drain, ensure that the drain is always submerged in the fluid.

Otherwise, add a check valve to the drain as shown in the diagram:

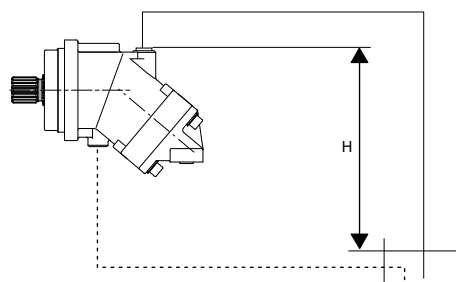



## ► How to determine the correct motor for your application

### Calculations using usual mechanical units:

- N = rotating speed (rpm)
- C = Torque (N.m)
- $\Delta P$  = Pressure difference between A and B (bar)
- Cy = Displacement cc/rev
- Q = Flow (l/min)
- $\eta$  = Efficiency (%)

### 1. Torque supplied by the hydraulic motor

$$\text{Theoretical torque} = \frac{C_y \times \Delta P}{20 \pi} = C_{th}$$

$$\text{Torque } C = C_{th} \times \eta_{motor}$$

For example: a 50 cc/rev motor with a  $\Delta P$  of 250 bar will supply a theoretical torque of 200 N.m.  
Average global efficiency of the motor is 90%, actual torque is thus: 180 N.m).

### 2. Rotating speed of the motor

The rotating speed of the hydraulic motor depends on the flow Q which goes through it, and on the displacement of the motor.

$$N = \frac{Q}{\text{Displ.}} \times 1000$$

### ► Technical assistance

Our Customer Service would be pleased to assist in determining the right motor for your application.

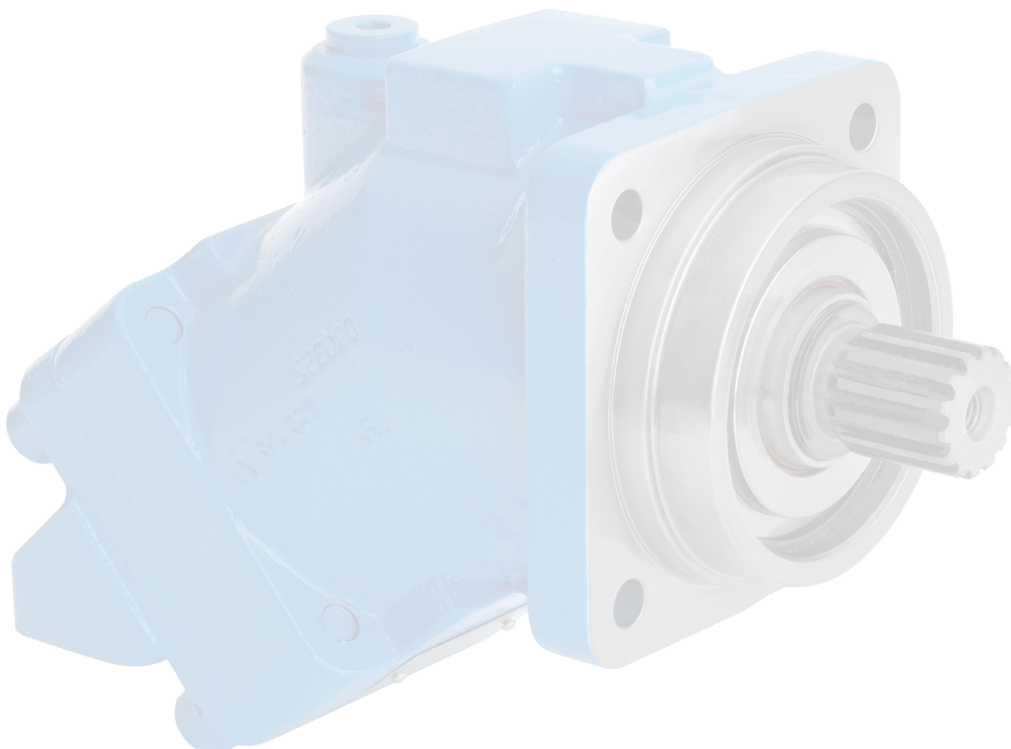

## ► Example

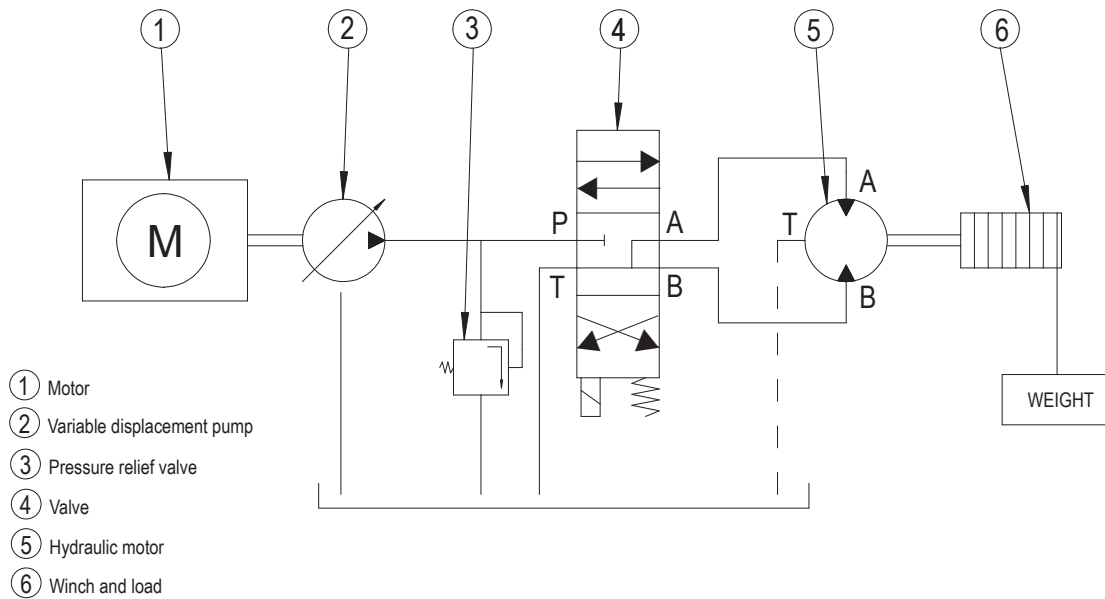

The receiving organ (winch) ⑥ needs to rotate at  $N = 400$  rpm and supply an actual torque of 200 N.m.  
 The hydraulic pump ② is capable of operating at pressure  $P$  up to 350 bar.

### 1. Calculating the displacement of the hydraulic motor:

$$C_{th} = \frac{\text{Disp.} \times \Delta P}{20 \pi} \text{ thus Disp.} = 35.9 \text{ cc/rev}$$

In the LEDUC range, choose a motor with a displacement of 32 cc/rev or 41 cc/rev.

### 2. Calculating the flow $Q$ which the pump needs to supply:

$$Q = \frac{N \times \text{Disp.}}{1000}$$

Corresponding flow:

- For 32 cc/rev motor,  $Q = 12.8$  l/min
- For 41 cc/rev motor,  $Q = 16.4$  l/min

## CHARACTERISTICS OF THE M SERIES MOTORS

Motor model	Displacement (cc/rev)	Continuous max. speed (1) (rpm)	Intermittent max. speed (1) (rpm)	Max. flow absorbed (l/mn)	Torque (N.m/bar)	Torque at 350 bar (N.m)	Theoretical maximal power at 400 bar (kW)	Max. allowable pressure continuous / peak (bar)	Weight (kg)
M 5	5	8000	8800	40	0.08	28	26.6	400 / 450	4.4
M 12	12	8000	8800	96	0.19	67	64	400 / 450	5.5
M 18	18.0	8000	8800	144	0.29	100	96	400 / 450	5.5
M 25	24.9	6300	6900	157	0.40	139	104.5	400 / 450	11.5
M 28	27.7	6300	6900	175	0.44	154	116.3	400 / 450	11.5
M 32	32.1	6300	6900	202	0.51	179	134.8	400 / 450	11.5
M 35	34.8	6300	6900	219	0.55	192.5	146	400 / 450	11,5
M 41	41.1	5600	6200	230	0.65	229	153.4	400 / 450	11.5
M 41 R (2)	41,1	5000	5500	206	0,65	229	137	400 / 450	18
M 45	45.4	5000	5500	227	0.72	253	151.3	400 / 450	18
M 50	50.3	5000	5500	252	0.80	280	167.6	400 / 450	18
M 63	63	5000	5500	315	1.00	351	210	400 / 450	18
M 80	80.4	4500	5000	362	1.28	448	241.2	400 / 450	23
M 90	90	4500	5000	405	1.43	501	270	400 / 450	23
M 108	108.3	4000	4400	433	1.72	603	288.8	400 / 450	23
M 108 R (3)	108.3	3400	4500	368	1.72	603	245.4	400 / 450	35
M 125	125.4	3400	4500	426	2.00	699	284.2	400 / 450	35
M 160	160	3600	4000	576	2.55	891	384	400 / 450	48.5
M 180	180.6	3600	4000	650	2.87	1006	433.4	400 / 450	48.5

(1) For higher speeds, please contact us.

(2) The M 41 R motor is in the frame size of the M 45.

► Acceptable forces applied to motor shaft

Motor model		5	12	18	25	28	32	35	41	41 R	45	50	63	80	90	108	108 R	125	160	180
Fr	N	710	2800	4000	6000	6200	6500	6500	7000	7000	6500	7500	9000	10500	11000	11500	12500	14500	18000	20000
Fa	N/bar *	10	15	20	27	28	30	34	40	40	40	40	50	60	67	80	80	86	85	95

Fr: radial force measured at mid point of length of shaft.

Fa: axial force which tends to push the shaft inwards.

\* Differential pressure between A and B.

For other forces, please contact us.

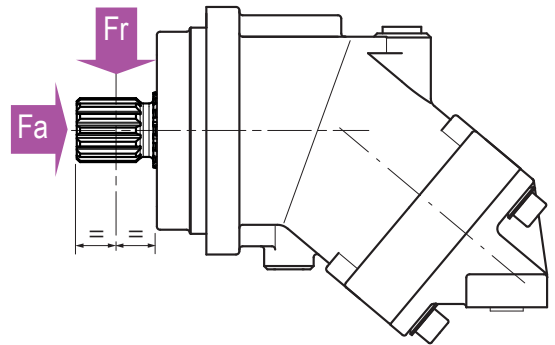
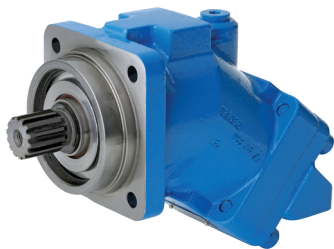

M	...	A	...	...	...	...	...	...	...	SP
01	02	03	04	05	06	07	08	09	10	11

To obtain the code for your motor, complete the different parameters 02, 04, 05, 06, 07, 08, 09 and 10 in the table on the left according to the options you require (see table below).

Motor																									
01	Motor																			M					
Displacement																									
02				5	12	18	25	28	32	35	41	41R	45	50	63	80	90	108	108R	125	160	180			
Mounting flange																									
03			CETOP 2 bolts	4 bolts ISO 3019-2																A					
Shaft																									
04	DIN 5480 splined	–	W25	W25	W25	W30	W30	W30	W30	W30	W30	W30	W30	W30	W40	W40	W40	W45	W45	W50	W50	W1			
		–	–	–	W30	W25	W25	W25	–	–	W35	W35	W35	W35	–	–	W40	W40	–	–	–	–	W2		
	DIN 6885 keyed	∅ 18	∅ 25	∅ 25	∅ 25	∅ 30	∅ 30	∅ 30	∅ 30	–	∅ 30	∅ 30	∅ 30	∅ 40	∅ 40	∅ 40	∅ 45	∅ 45	∅ 50	∅ 50	–	–	D1		
		–	∅ 20	–	∅ 30	∅ 25	∅ 25	∅ 25	–	∅ 35	∅ 35	∅ 35	∅ 35	–	–	–	∅ 40	–	–	–	–	–	–	D2	
Inlet ports A and B																									
05	SAE flange ports	Bottom	0	–	–	–	•	•	•	•	•	•	•	•	•	•	•	•	•	•	•	•	L0		
		Rear	0	–	–	•	•	•	–	•	•	•	•	•	•	•	•	•	•	•	•	•	•	M0	
		Side	0	–	–	•	•	•	–	•	•	•	•	•	•	•	•	•	•	•	•	•	•	•	N0
	1		–	–	•	•	•	–	•	•	•	•	•	•	•	•	•	•	•	•	•	•	•	N1	
	Threaded	Side	0	–	•	•	•	•	•	–	•	•	•	•	•	•	•	•	•	•	•	•	•	•	Q0
			1	–	–	•	•	•	–	•	•	•	•	•	•	•	•	•	•	•	•	•	•	•	Q1
Rear		0	•	•	•	•	•	•	–	•	•	•	•	•	•	•	•	•	•	•	•	•	•	P0	
		0 = Without suitability for valves 1 = Compatible with flushing valve																							
Drain ports T1 and T2																									
06			–	•	•	•	•	•	•	•	•	•	•	•	•	•	•	•	•	•	•	•	M2		
			•	–	–	–	–	–	–	–	–	–	–	–	–	–	–	–	–	–	–	–	–	G2	
Suitable for use of speed sensor																									
07	Yes		•	•	•	•	•	•	•	•	•	•	•	•	•	•	•	•	•	•	•	•	1		
	No		•	•	•	•	•	•	•	•	•	•	•	•	•	•	•	•	•	•	•	•	•	0	
Speed sensor																									
08	1 frequency signal		•	•	•	•	•	•	•	•	•	•	•	•	•	•	•	•	•	•	•	•	•	1	
	1 signal with connector		•	•	•	•	•	•	•	•	•	•	•	•	•	•	•	•	•	•	•	•	•	1P	
	2 signals with connector		○	○	○	○	○	○	○	○	○	○	○	○	○	○	○	○	○	○	○	○	○	2P	
	Without		•	•	•	•	•	•	•	•	•	•	•	•	•	•	•	•	•	•	•	•	•	0	
Flushing valve																									
09	Without		•	•	•	•	•	•	•	•	•	•	•	•	•	•	•	•	•	•	•	•	•	SV	
	Flow rate	4,25 l/min*	–	–	–	•	•	•	•	•	•	•	•	•	•	•	•	•	•	•	•	•	•	VB04	
		10 l/min*	–	–	–	•	•	•	•	•	•	•	•	•	•	•	•	•	•	•	•	•	•	VB10	
		14 l/min*	–	–	–	•	•	•	•	•	•	•	•	•	•	•	•	•	•	•	•	•	•	VB14	
Low temperature option																									
10	Yes (NBR)		–	•	•	•	•	•	•	•	•	•	•	•	•	•	•	•	•	•	•	•	•	N	
	No (FKM)		•	•	•	•	•	•	•	•	•	•	•	•	•	•	•	•	•	•	•	•	•	•	F

**Legend:**

- Existing model
- On request
- Not available

\*(Δp = 25 bar)

## CETOP flange, 2 bolts

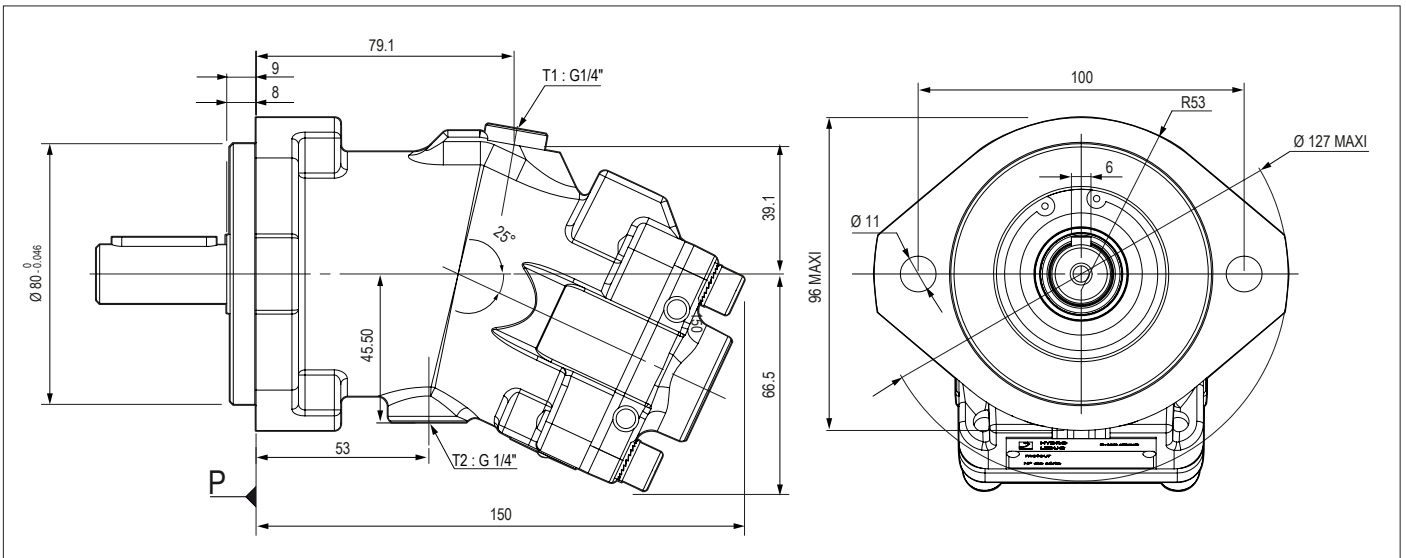

## ► Shaft end

**D1** Cylindrical keyed shaft  $\varnothing 18$   
AS 6 x 6 x 32

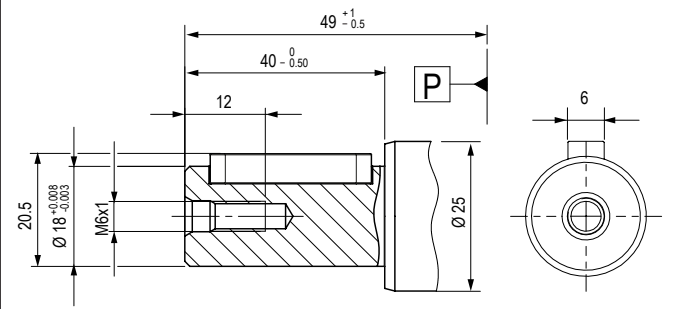

## ► Inlet ports

**P0** Rear threaded ports A and B

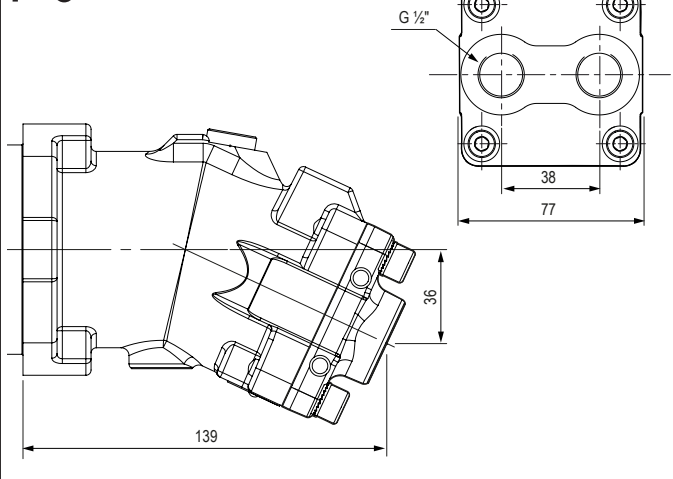

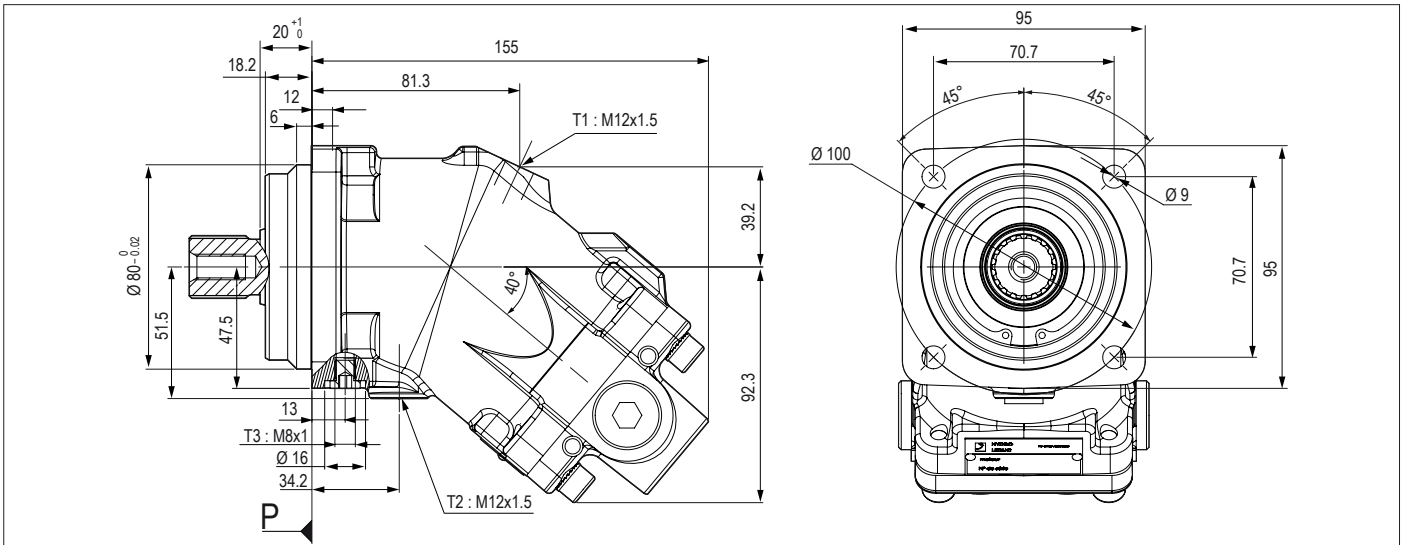

► Shaft

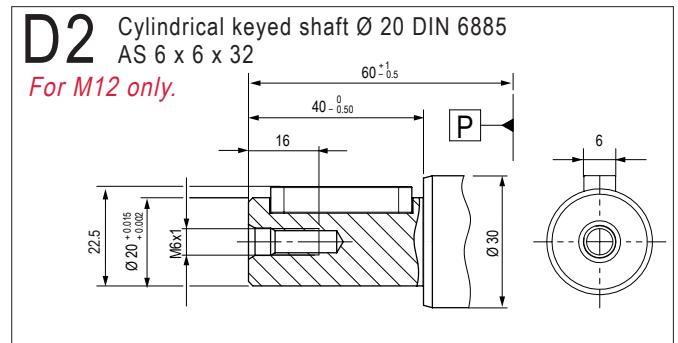
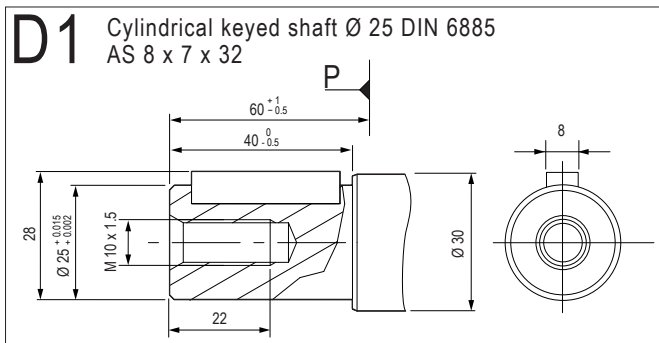
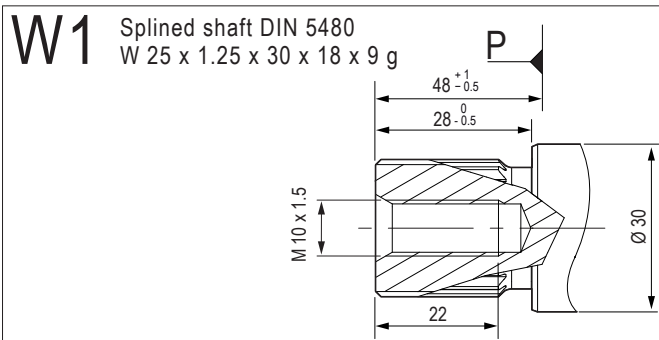

► Inlet ports

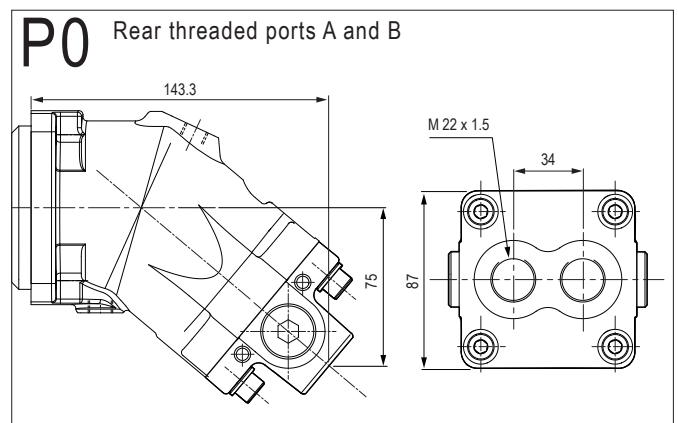
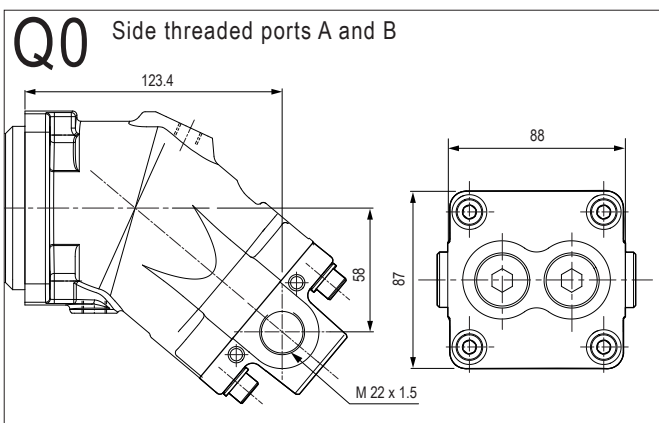

Dimensions in mm are given only as an indication.

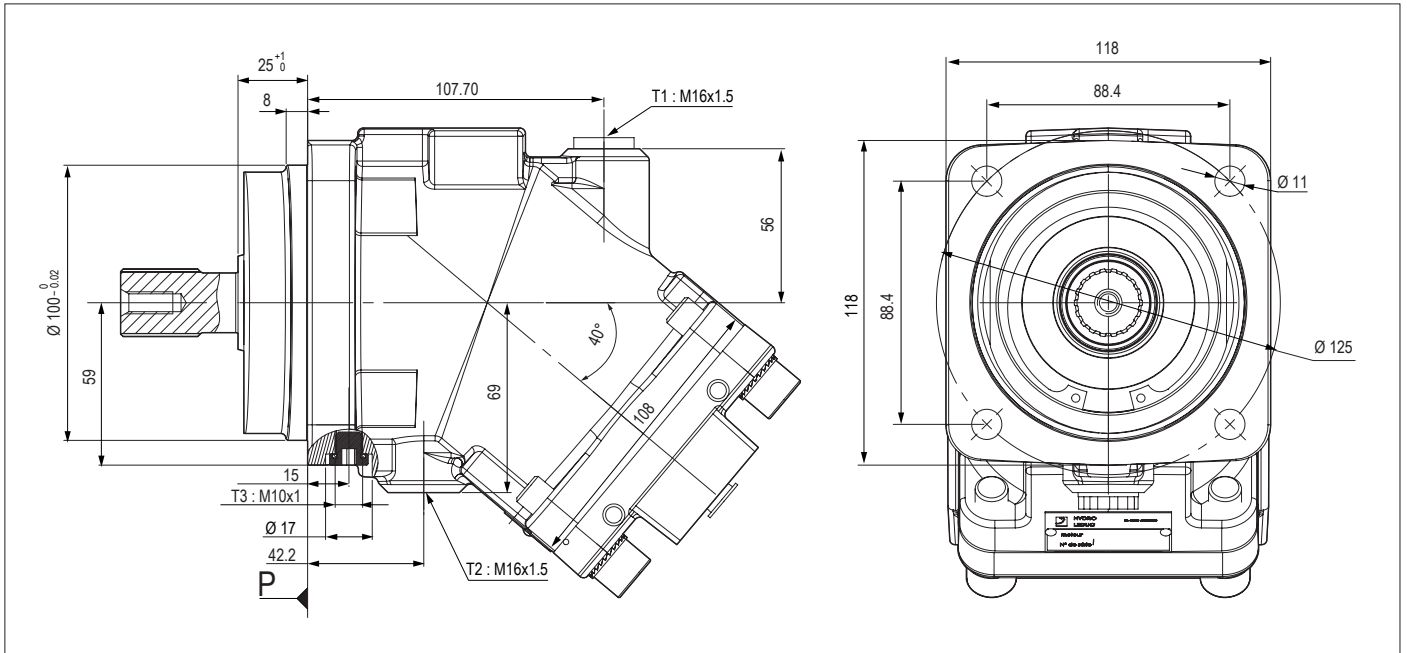

### ► Shaft end

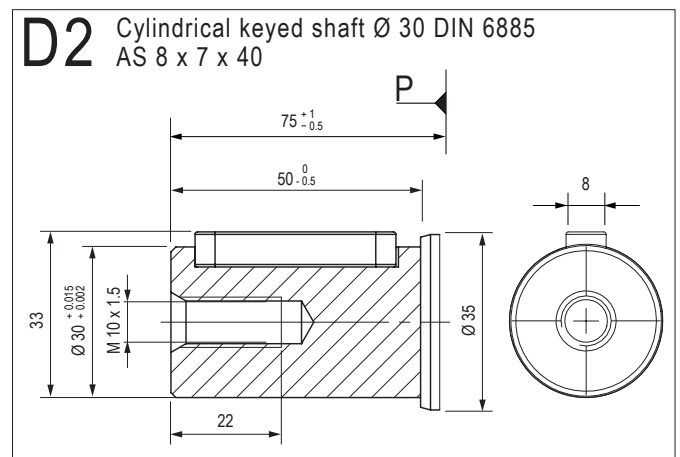
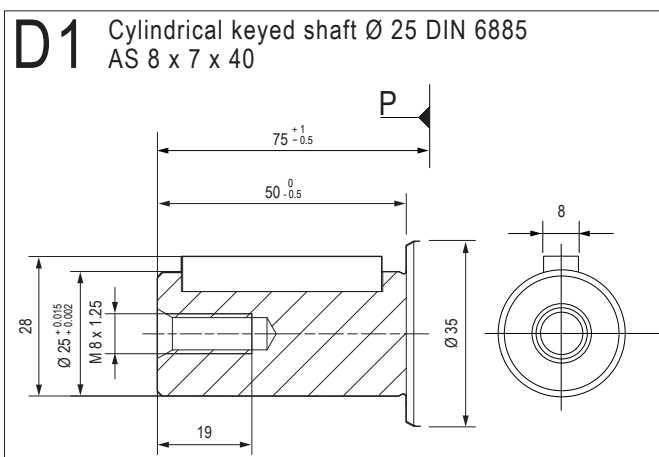
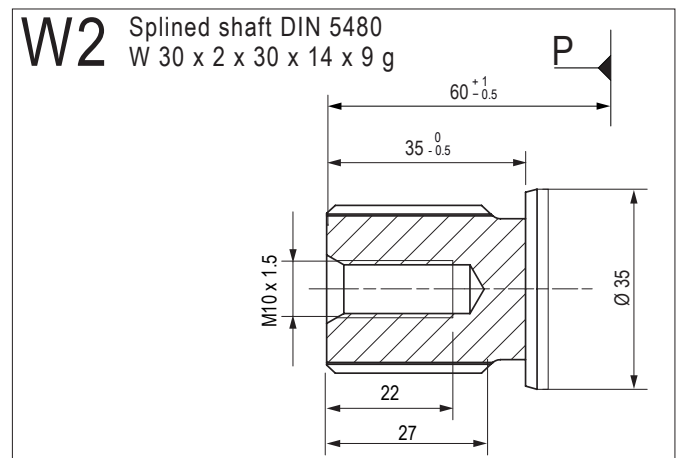
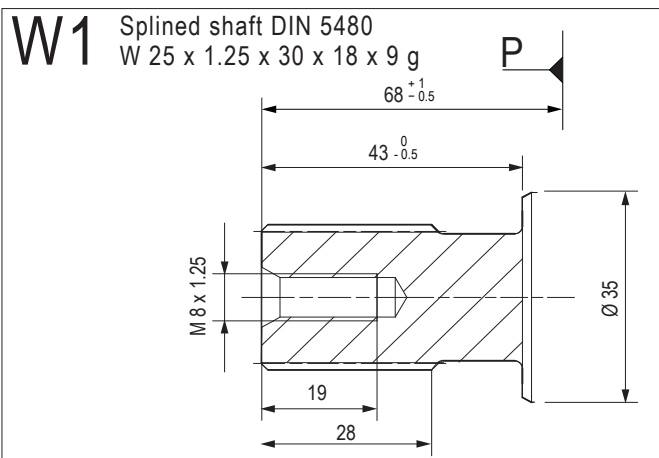



► Inlet ports

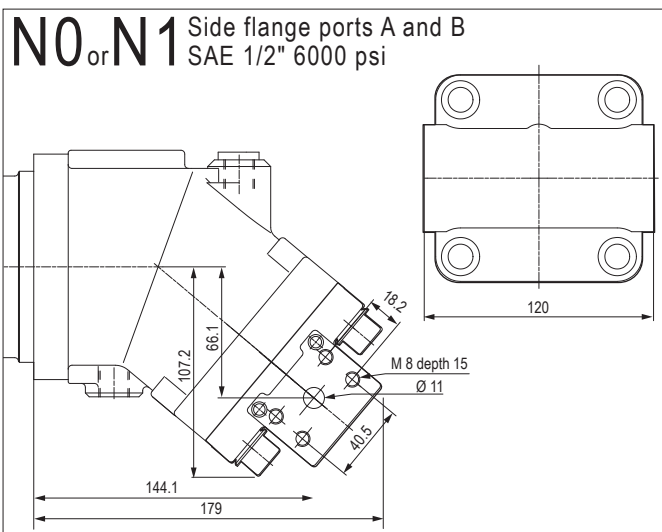
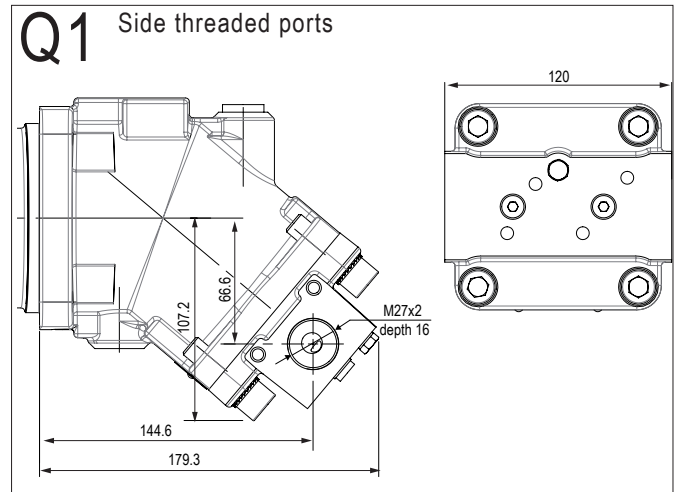
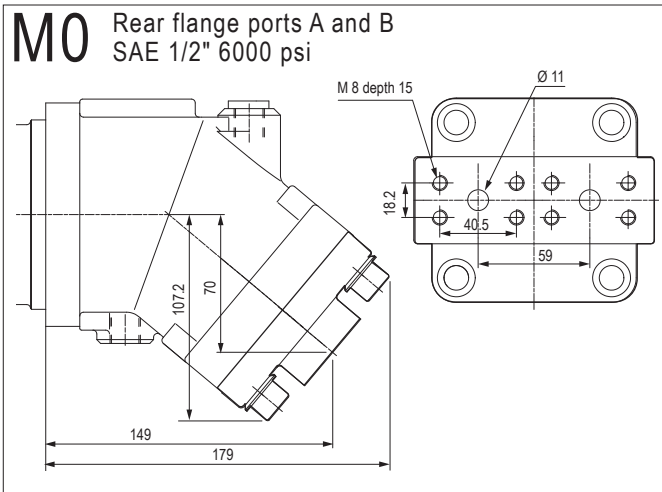
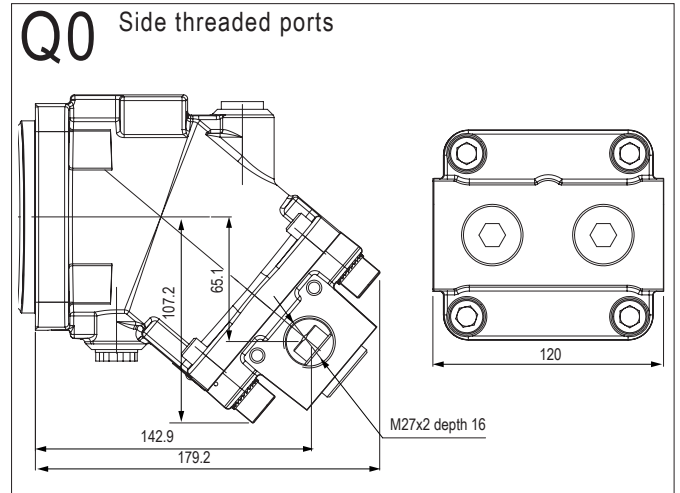
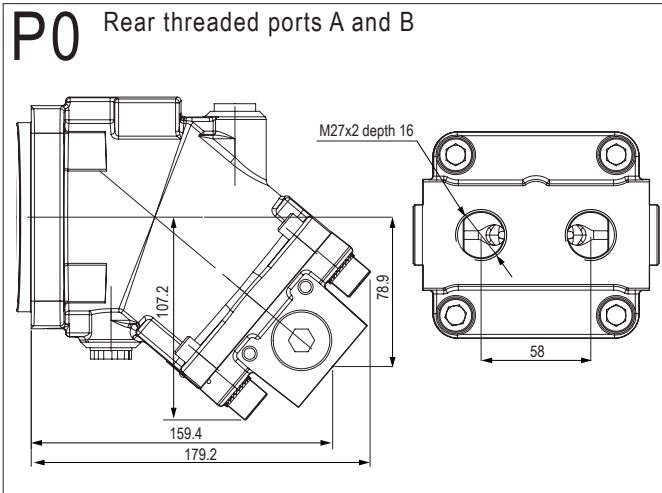

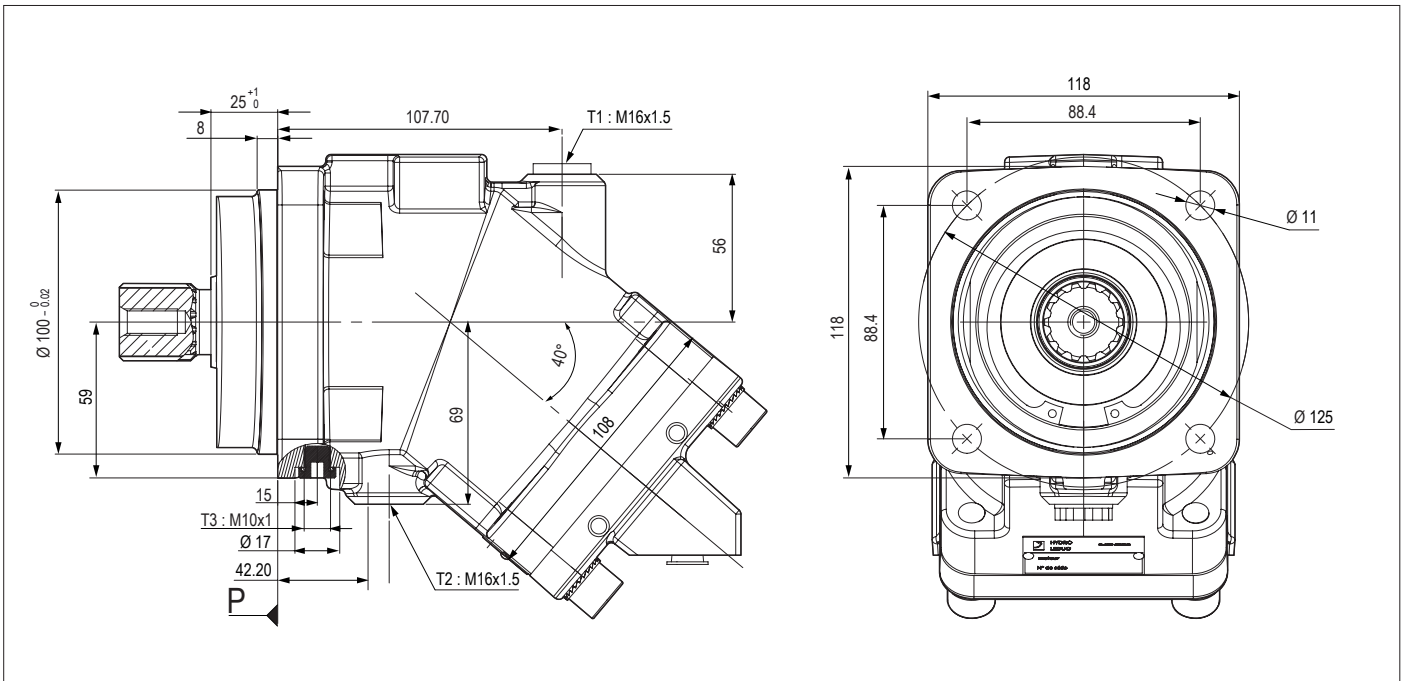

► Shaft end

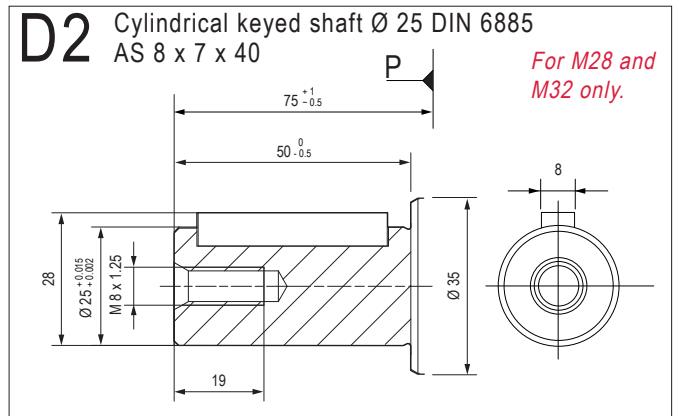
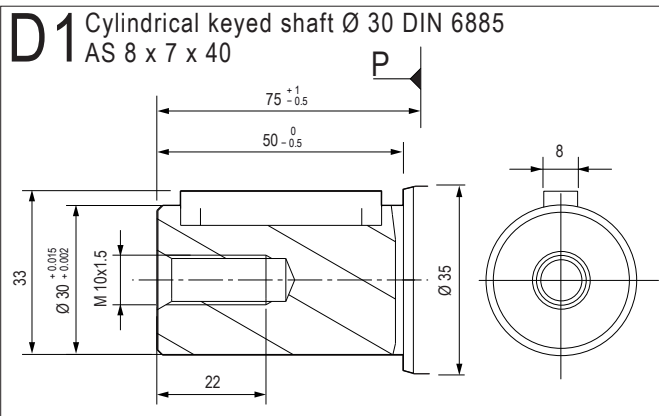
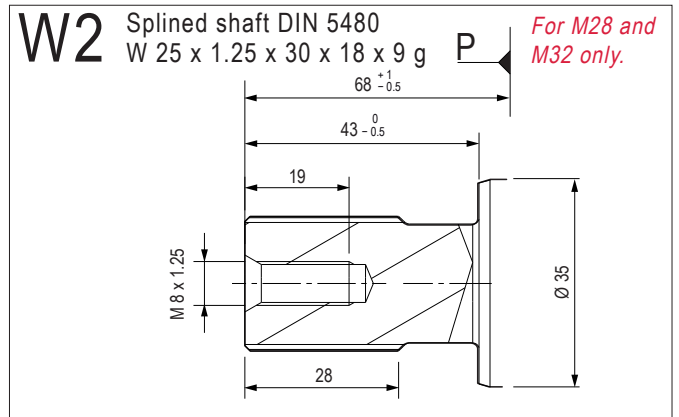
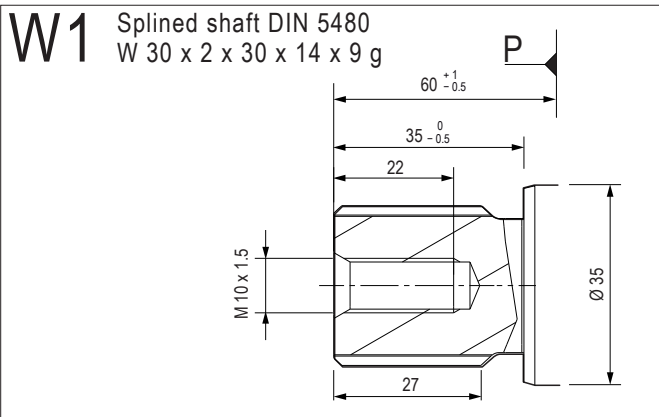

► Inlet ports

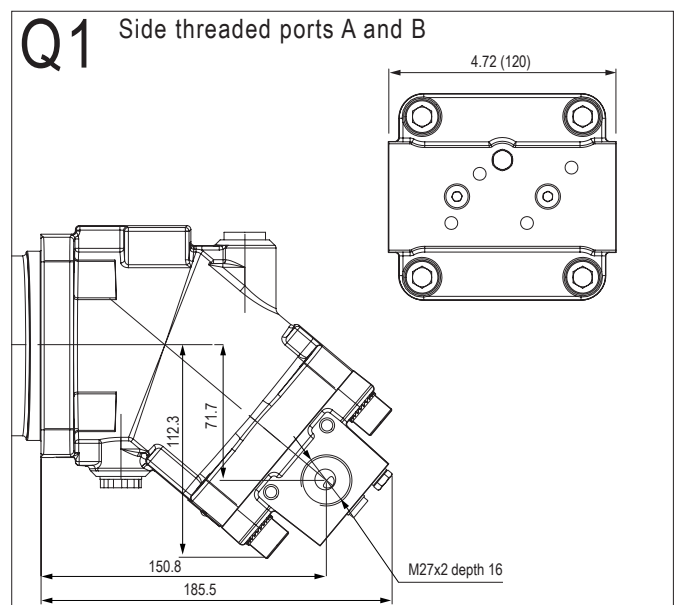
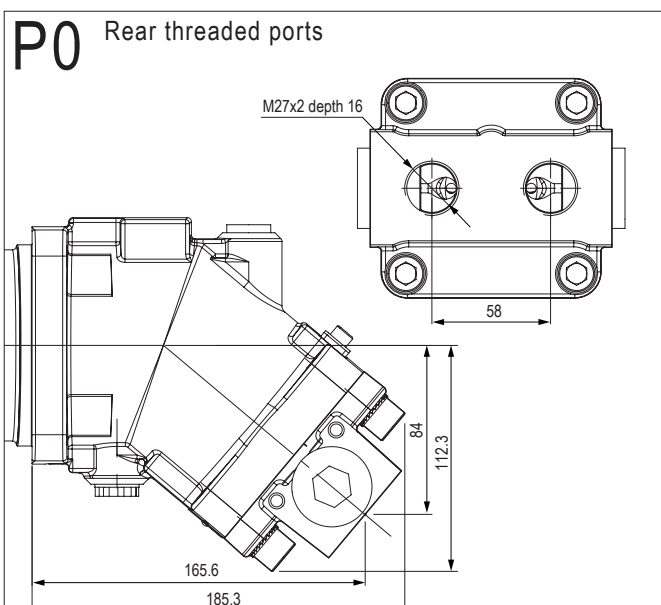
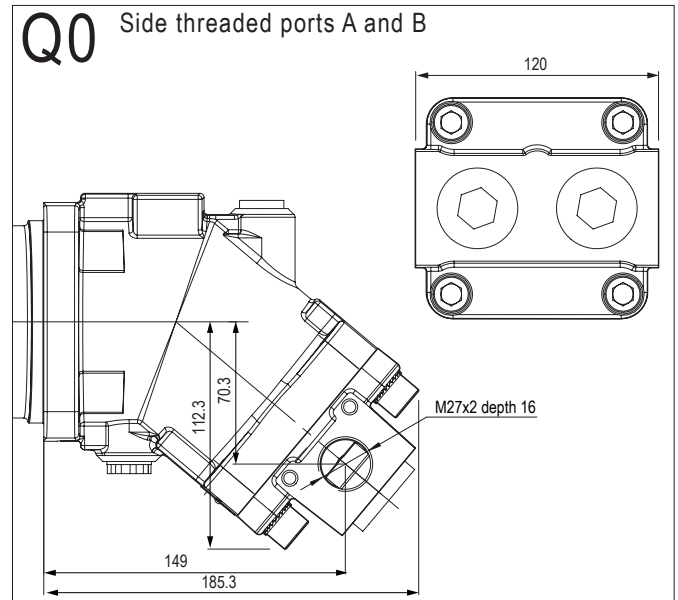
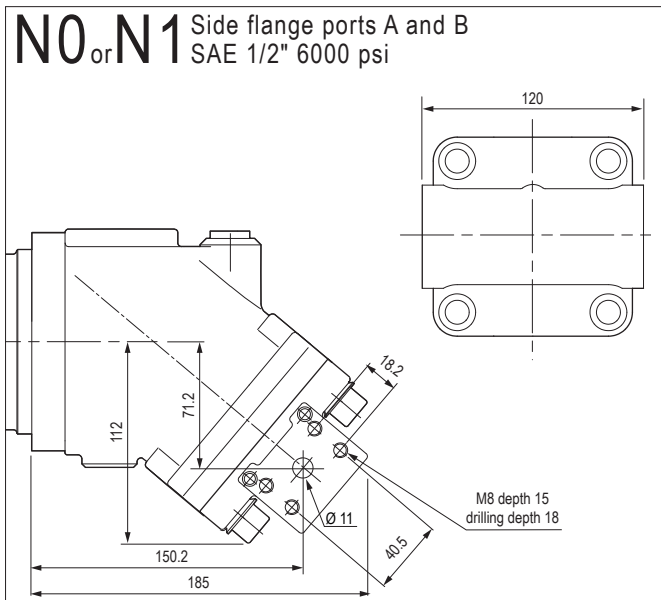
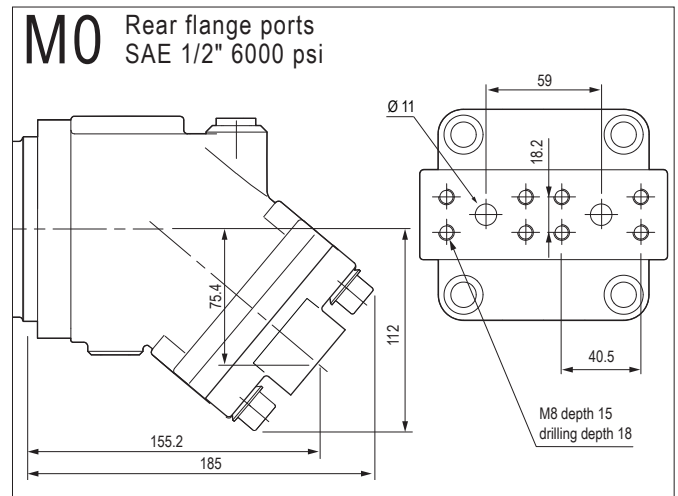
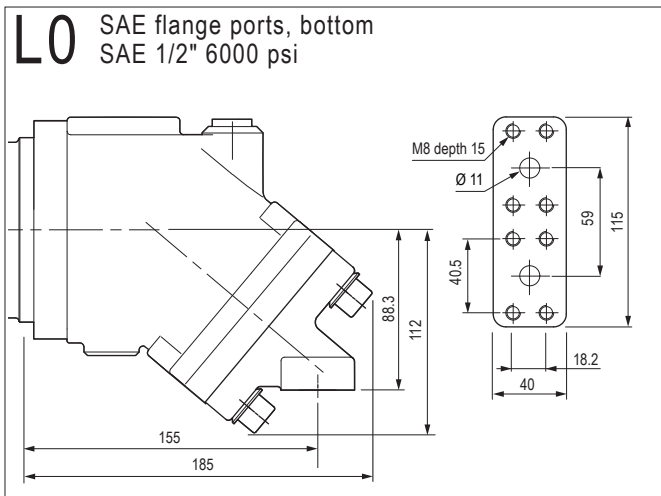

M series

Dimensions in mm are given only as an indication.

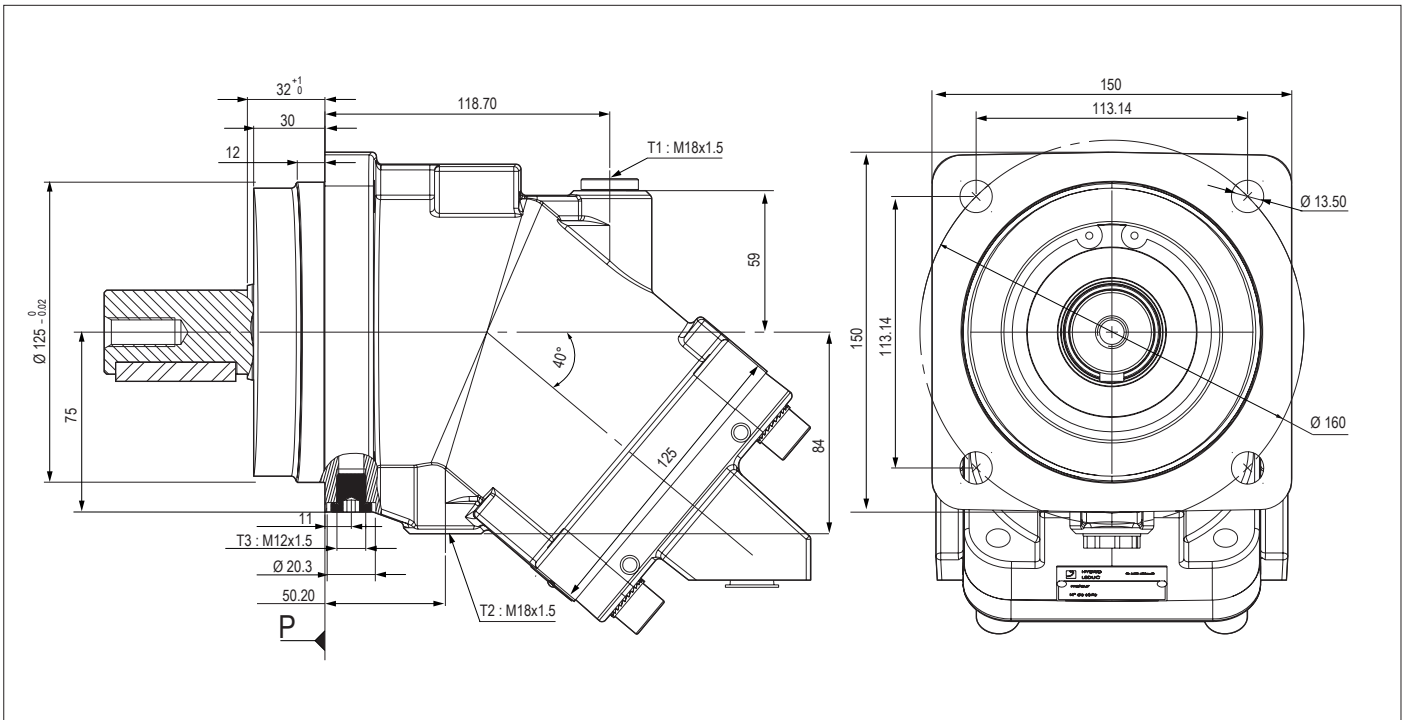

### ► Shaft end

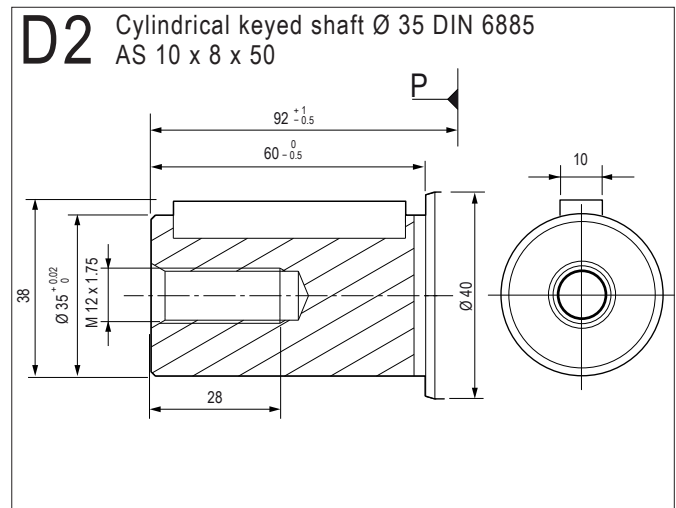
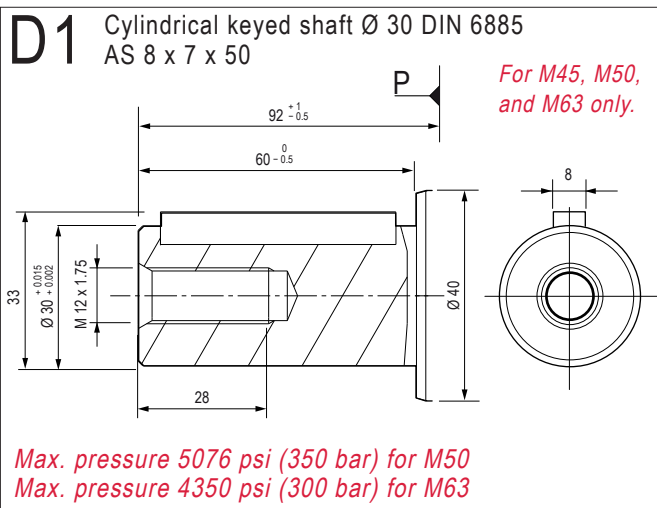
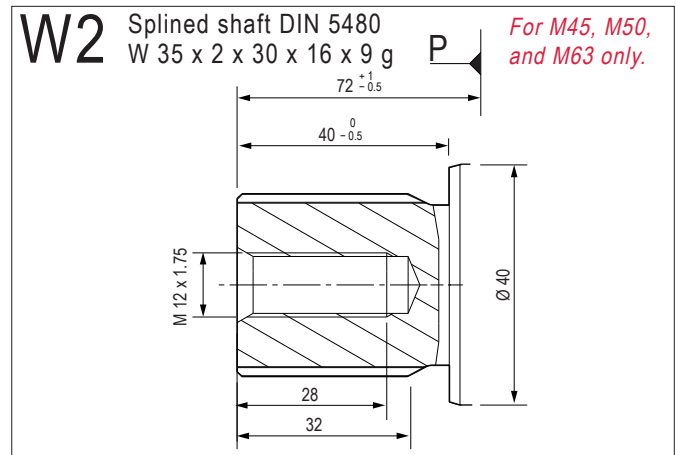
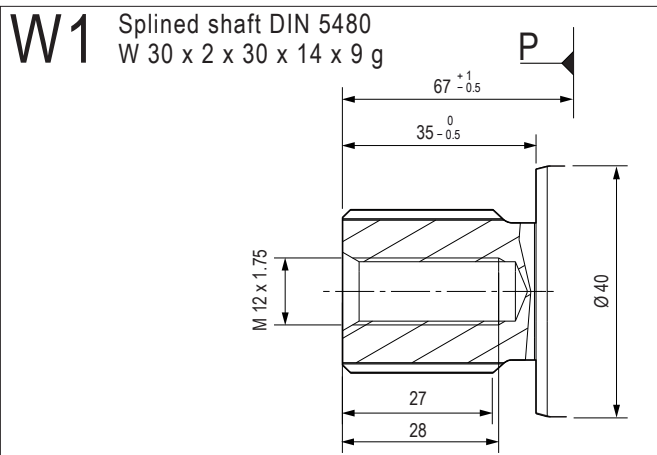

Dimensions in mm are given only as an indication.

► Inlet ports

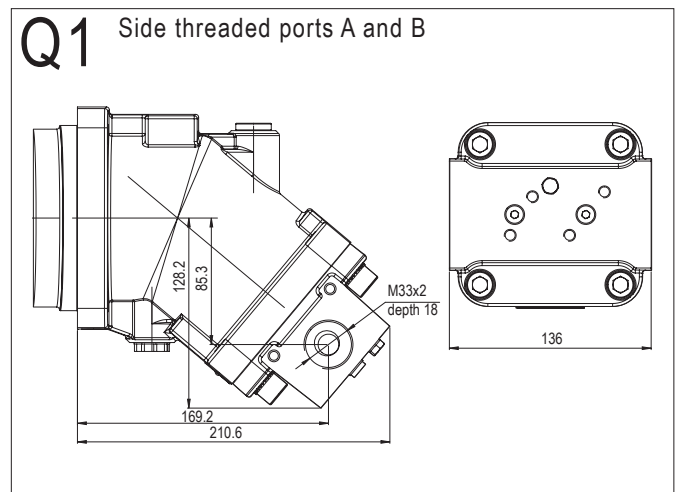
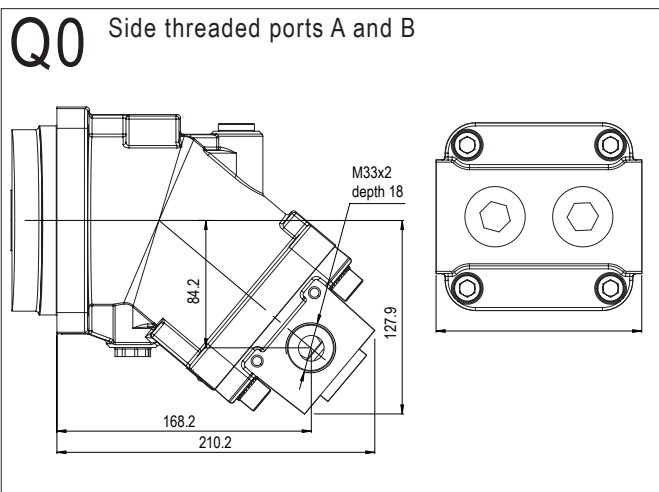
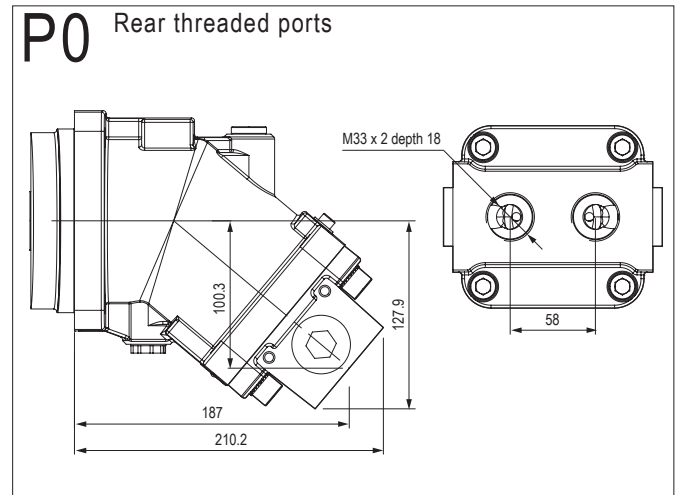
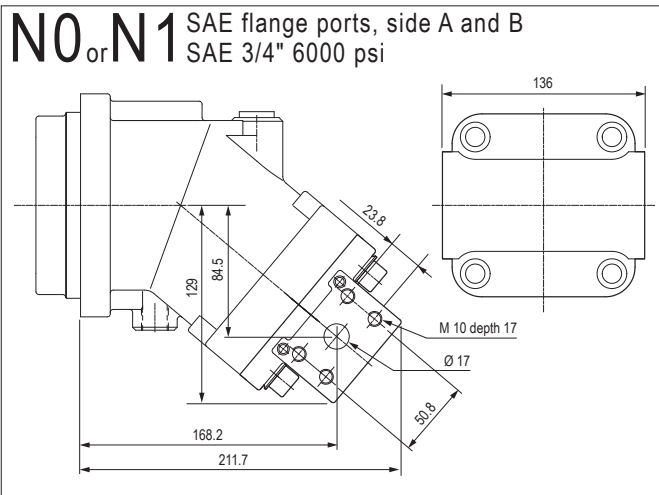
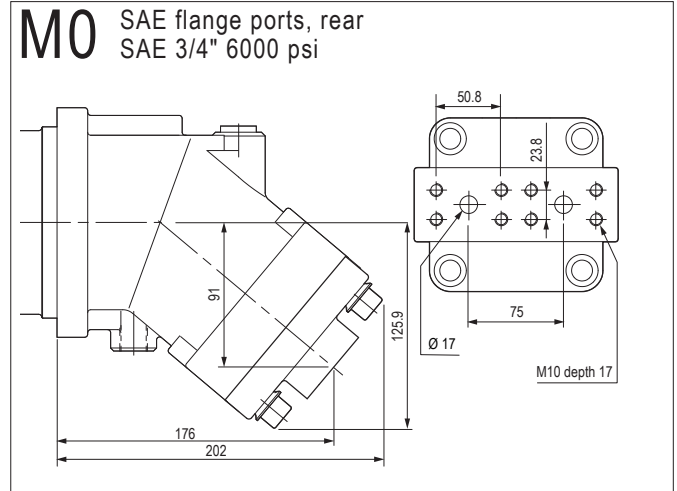
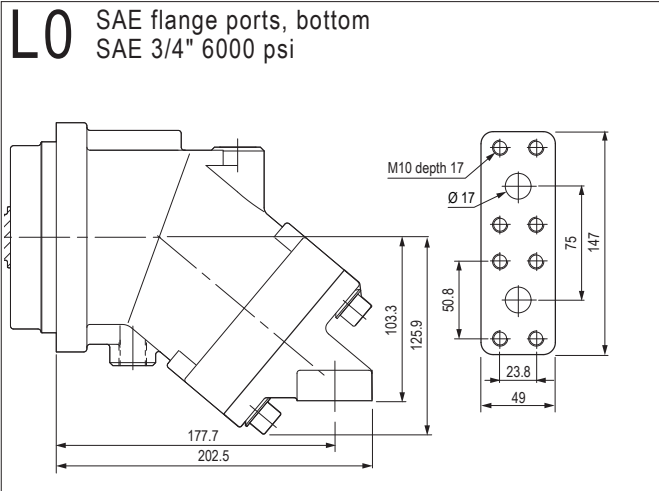

M series

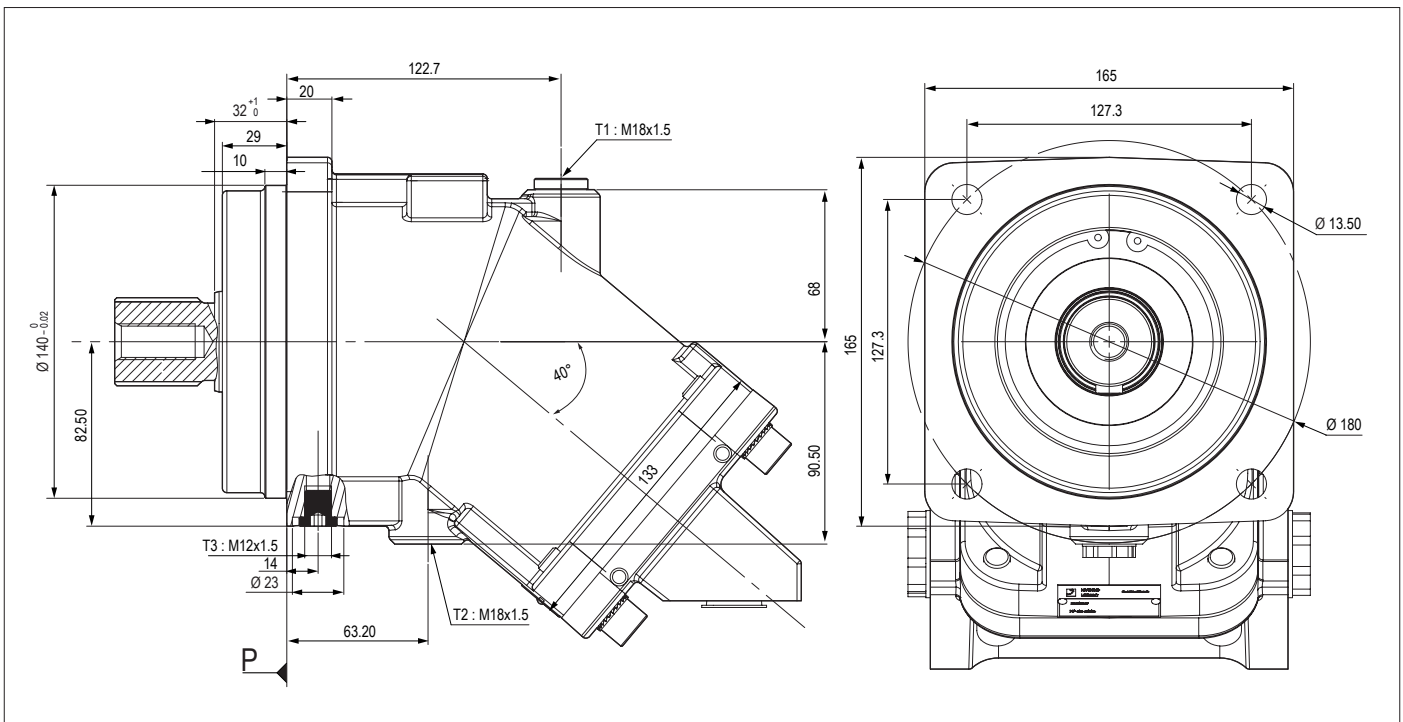

► Shaft end

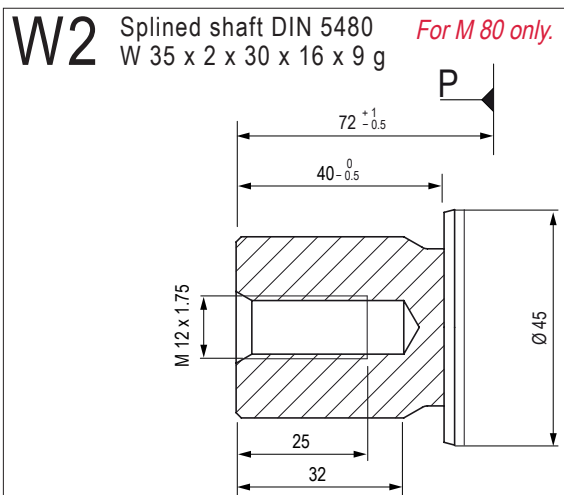
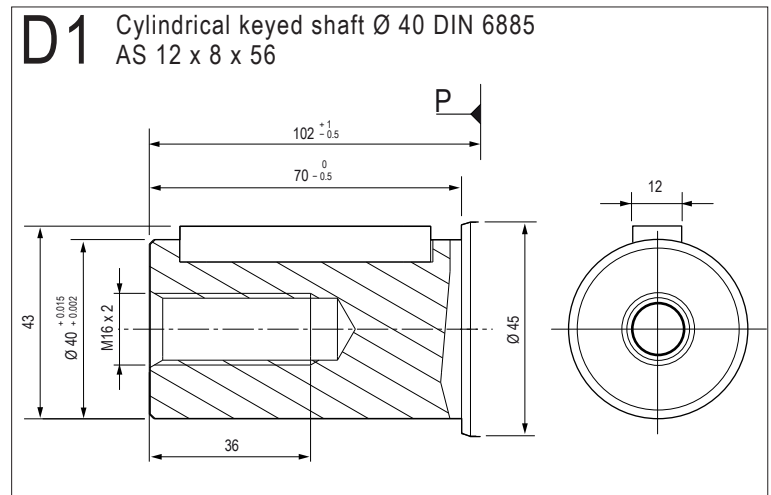
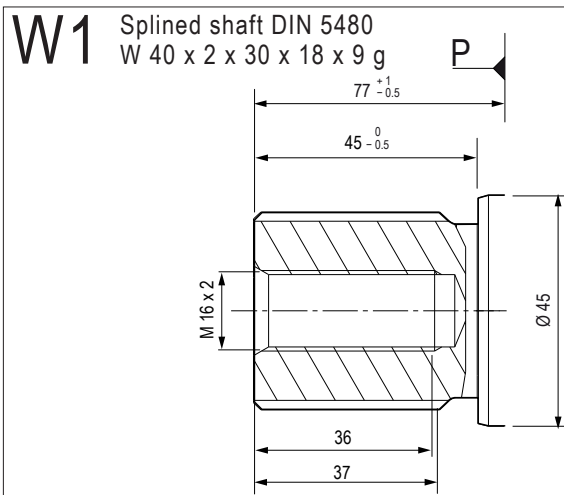

Dimensions in mm are given only as an indication.

► Inlet ports

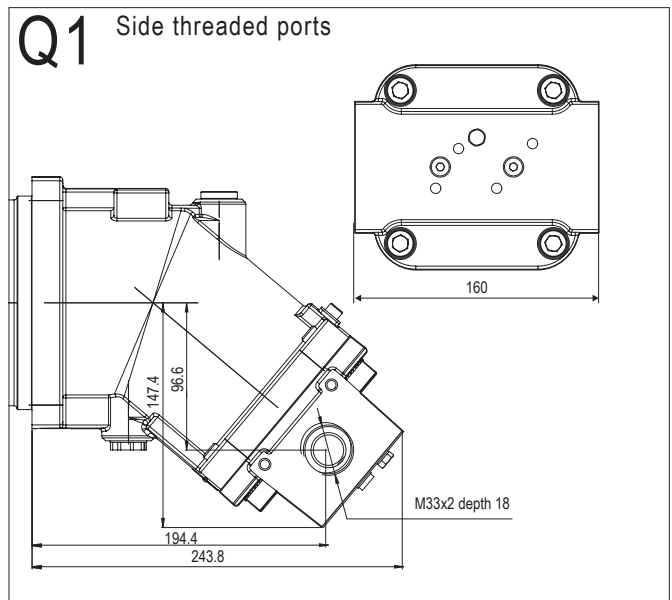
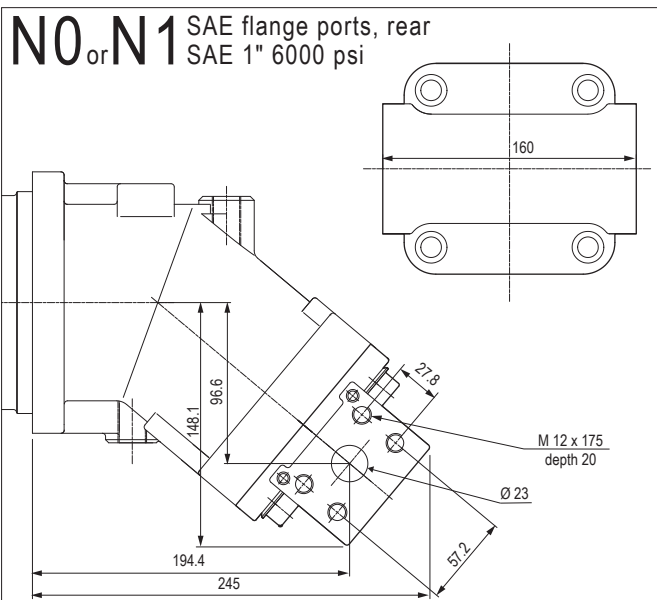
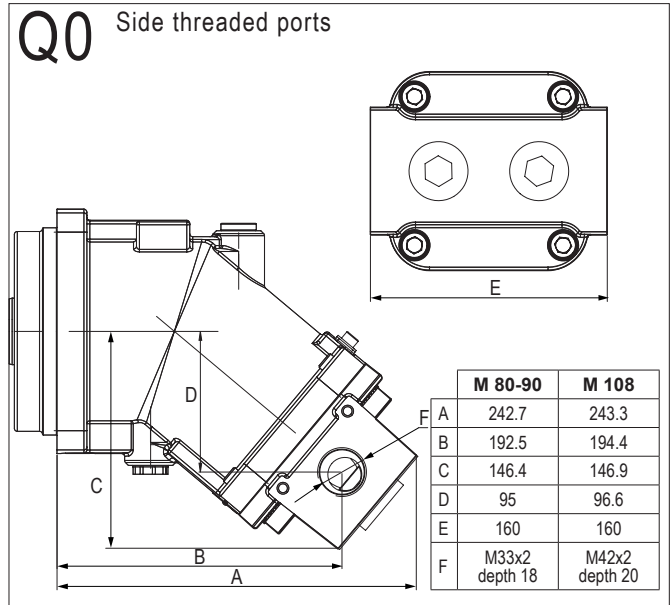
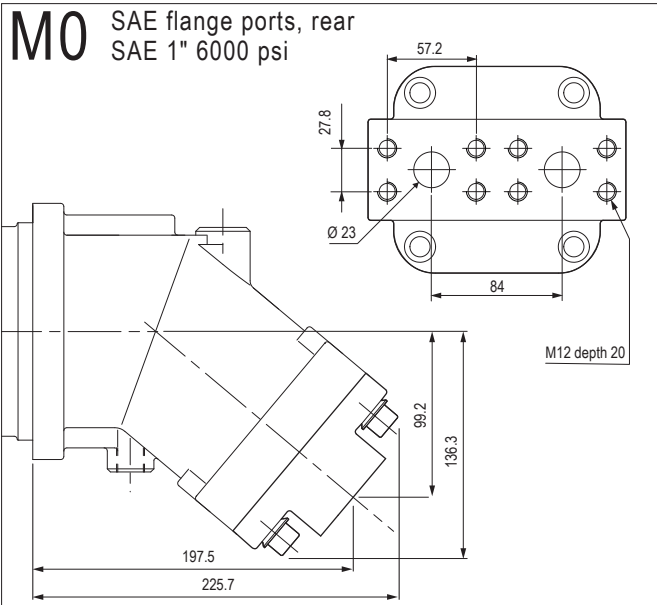
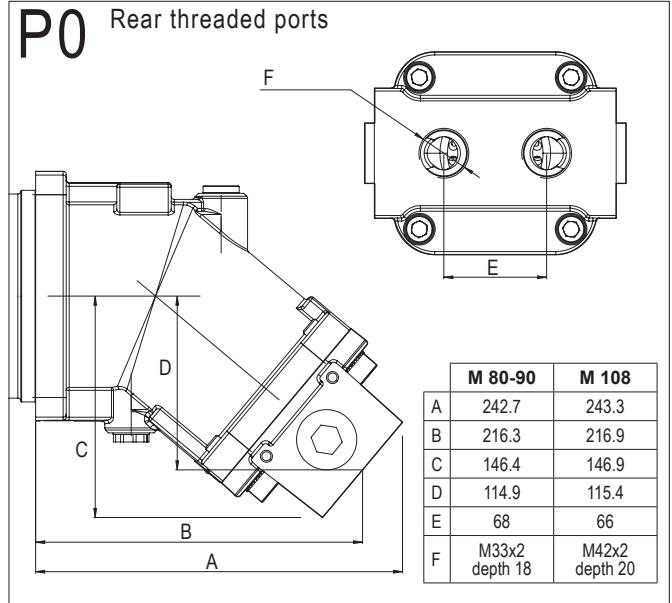
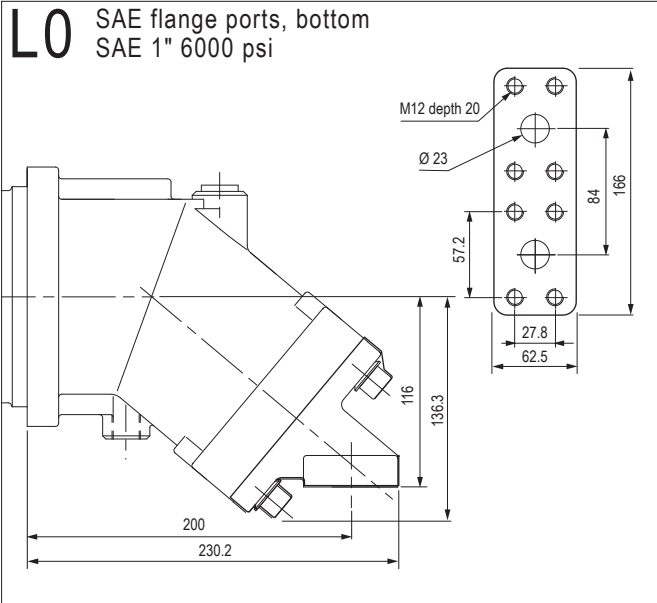

Dimensions in mm are given only as an indication.

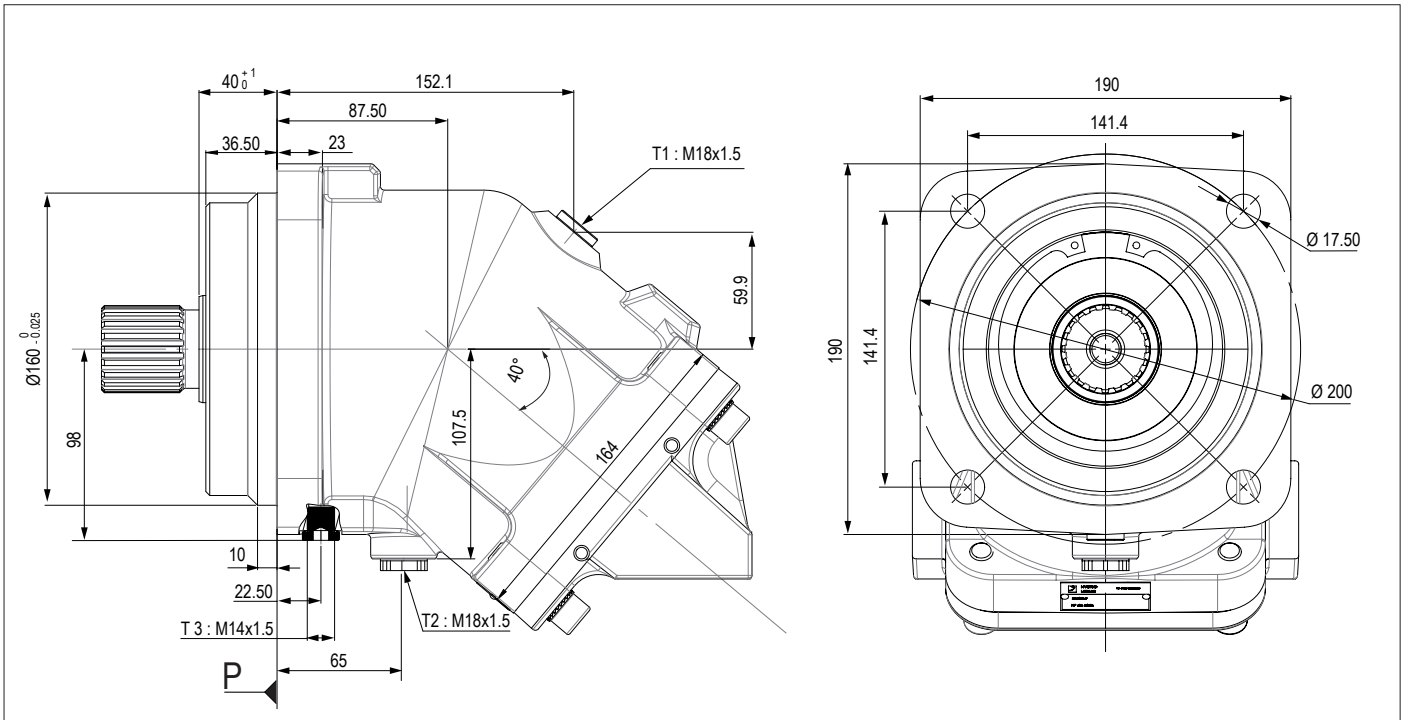

► Shaft end

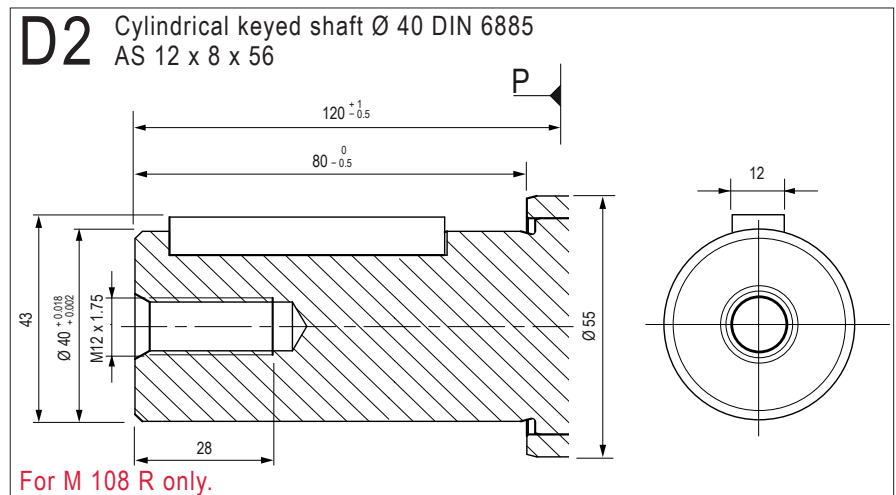
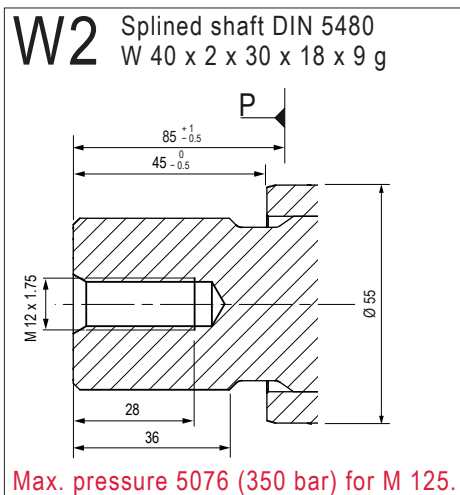
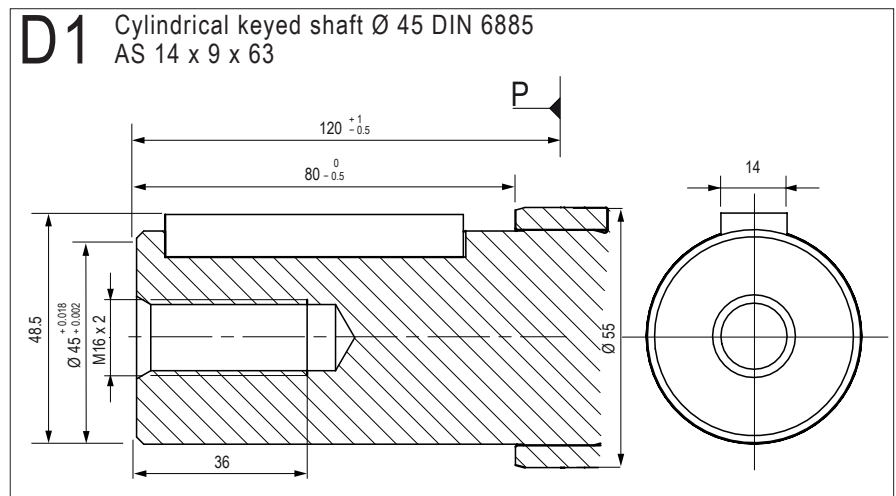
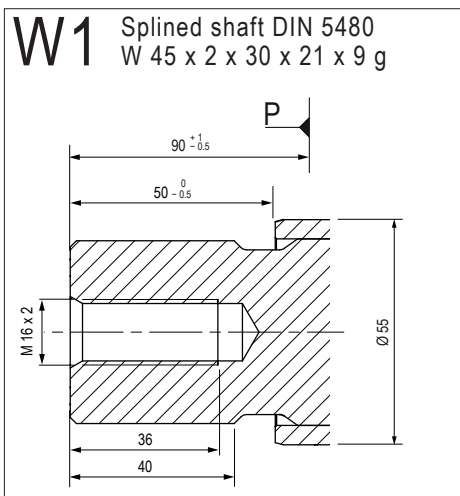



► Inlet ports

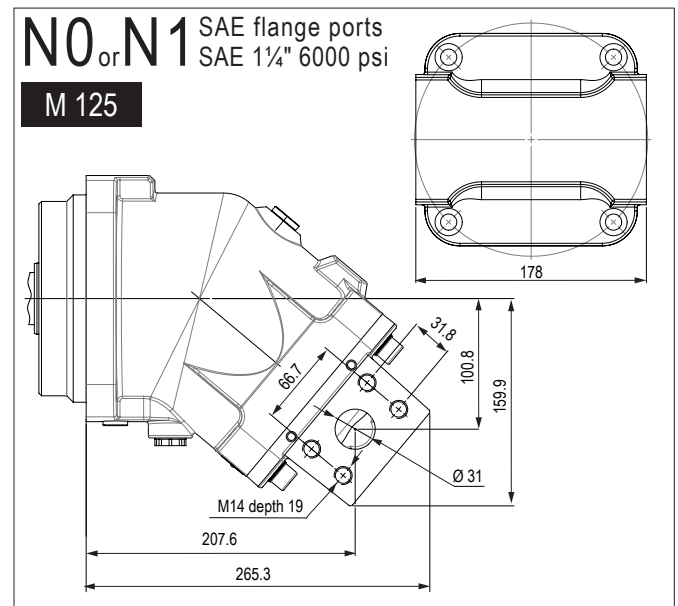
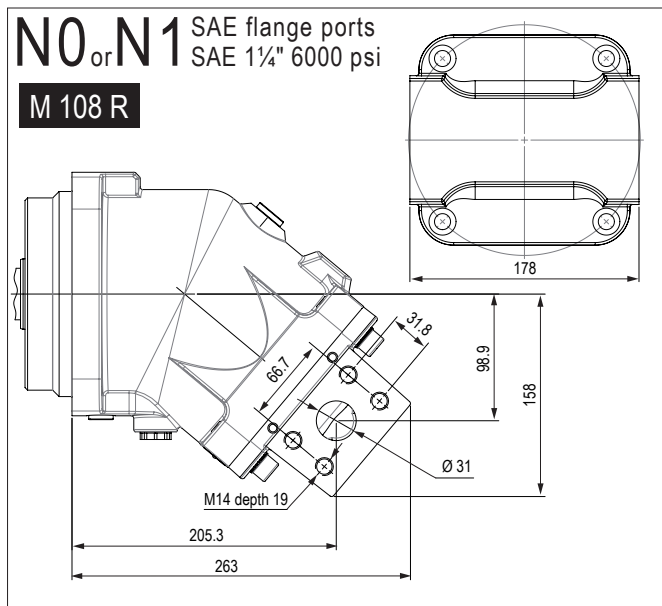
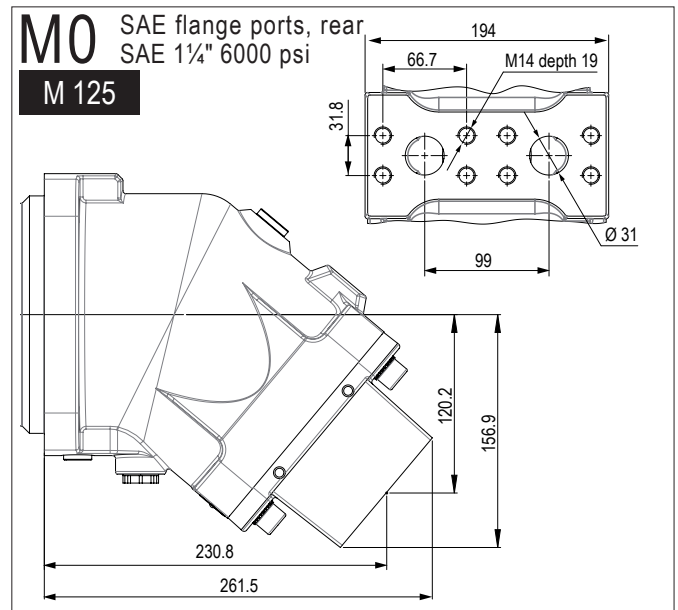
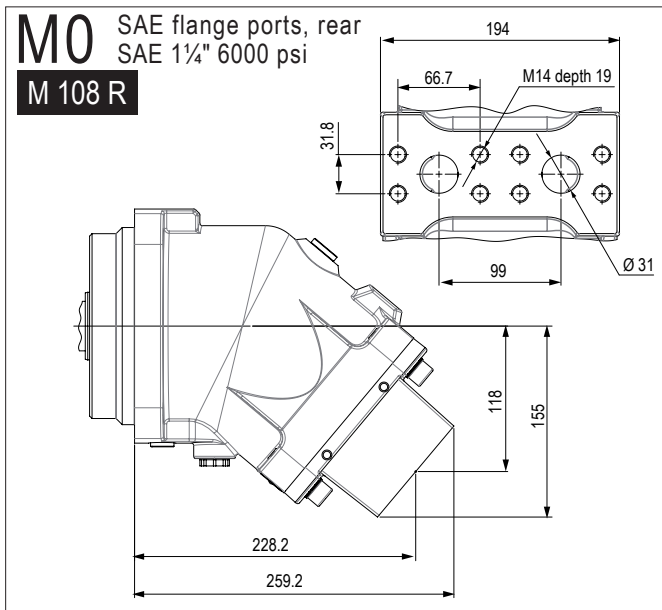
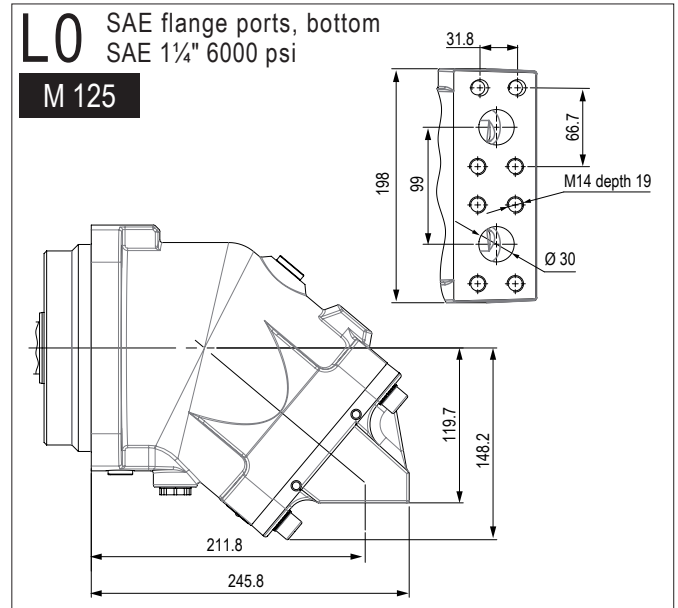
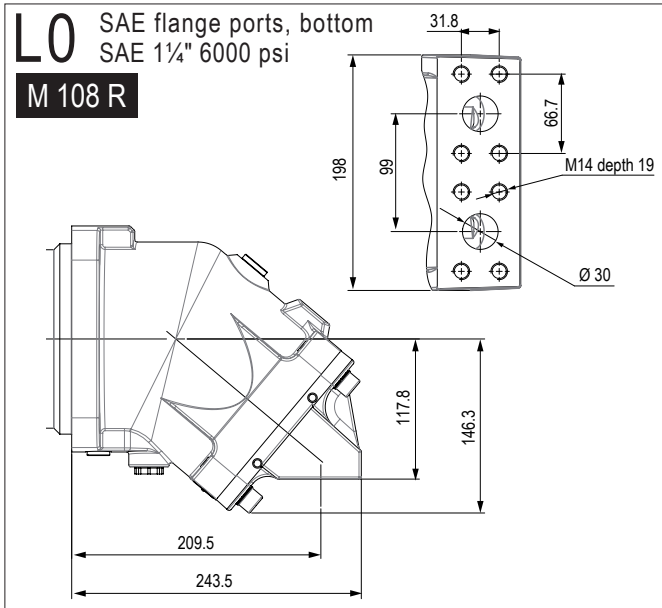

Dimensions in mm are given only as an indication.

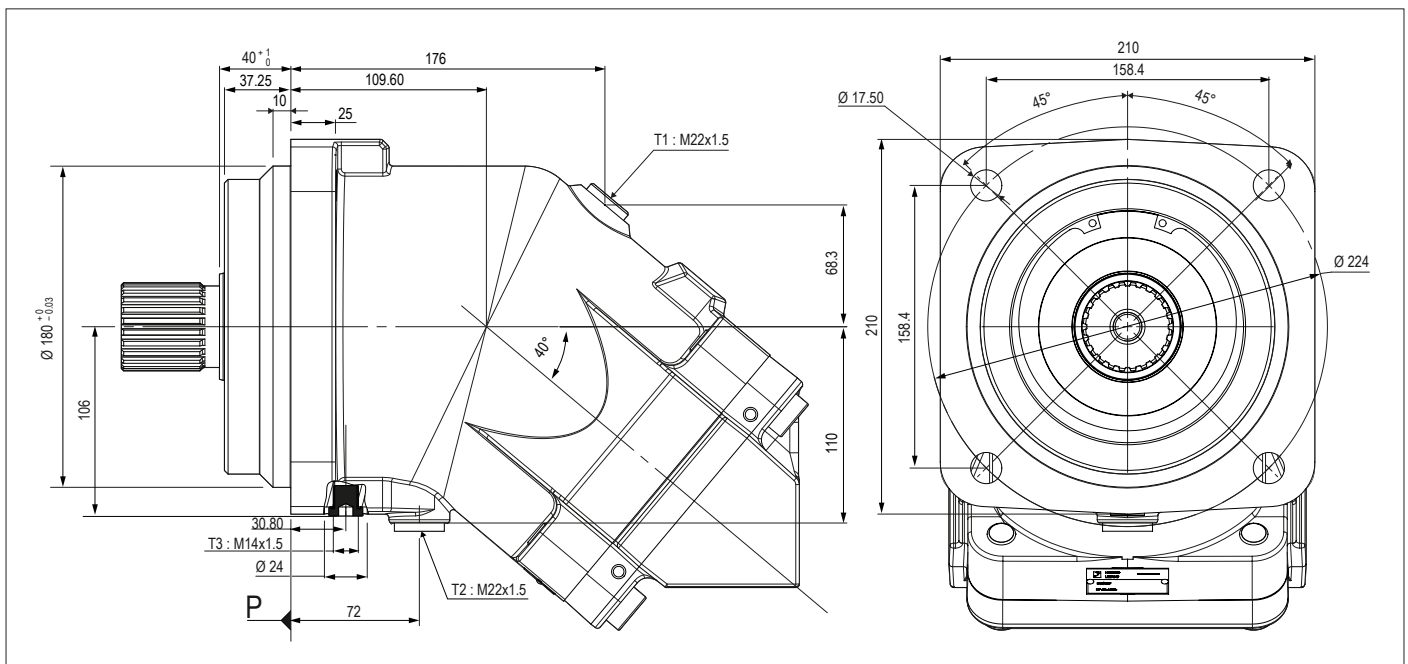
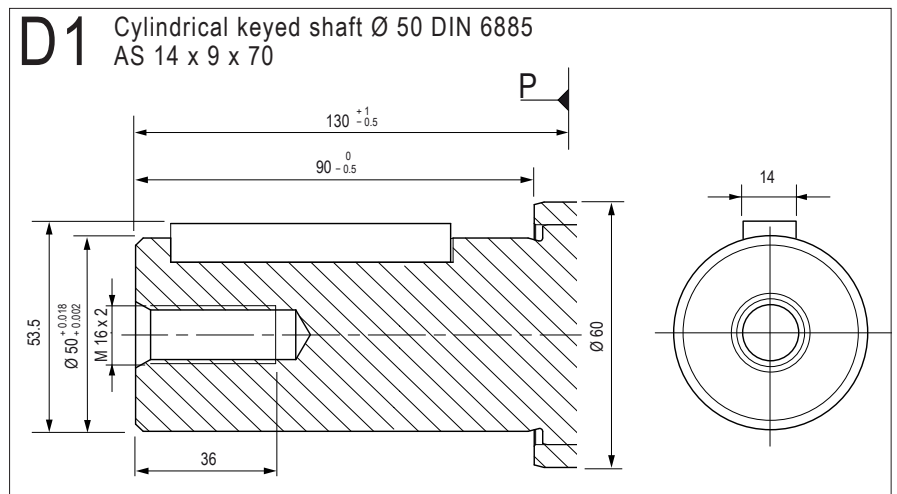
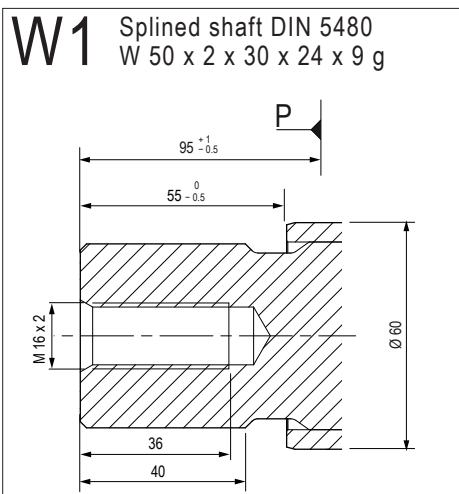
**► Shaft end**

► Inlet ports

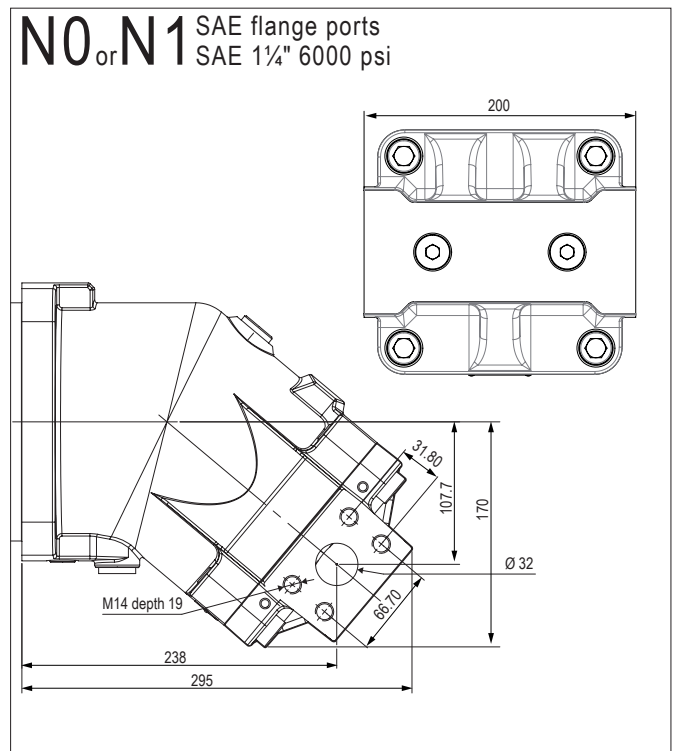
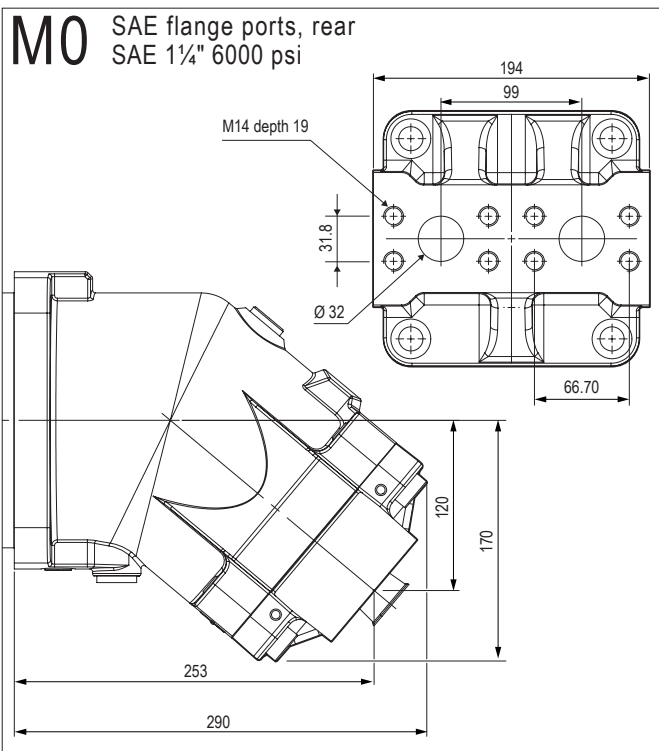
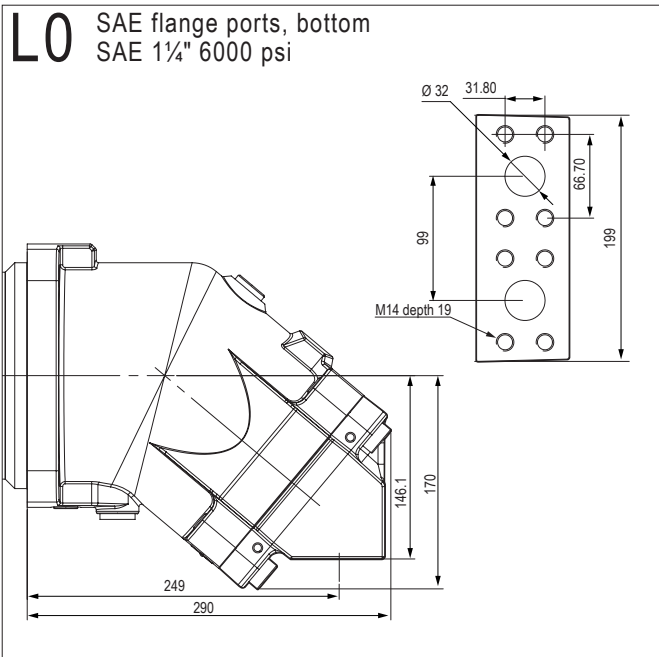

Dimensions in mm are given only as an indication.

## CHARACTERISTICS OF THE MA SERIES MOTORS (SAE)

Motor model	Displacement		Continuous max. speed (1)	Intermittent max. speed (1)	Max. flow absorbed		Torque		Torque at 350 bar (5100 psi)		Theoretical maximal power at 5800 psi 400 bar		Max. allowable pressure continuous / peak		Weight (kg)	
	cu.in/rev	cc/rev			rpm	rpm	gpm	l/mn	lbf.ft/psi	N.m/bar	lbf ft	N.m	HP	kW	psi	bar
MA 10	0,62	10,2	8000	8800	21,6	82	0,0082	0,16	42	57	72,9	54,4	5800 / 6525	400 / 450	14,3	6,5
MA 12	0,73	12,0	8000	8800	25,4	96	0,0097	0,19	49	67	85,7	64	5800 / 6525	400 / 450	14,3	6,5
MA 16	0,99	16,2	8000	8800	34,2	130	0,0131	0,26	67	90	115,9	86,4	5800 / 6525	400 / 450	14,3	6,5
MA 18	1,10	18,0	8000	8800	38,0	144	0,0145	0,29	74	100	128,7	96	5800 / 6525	400 / 450	14,3	6,5
MA 25	1,52	24,9	6300	6900	41,4	157	0,0201	0,40	102	139	140,1	104,5	5800 / 6525	400 / 450	25	11,5
MA 32	1,96	32,1	6300	6900	53,4	202	0,0259	0,51	132	179	180,7	134,8	5800 / 6525	400 / 450	25	11,5
MA 41	2,51	41,1	5600	6200	60,8	230	0,0331	0,65	169	229	205,6	153,4	5800 / 6525	400 / 450	25	11,5
MA 45	2,77	45,4	5000	5500	60,0	227	0,0366	0,72	187	253	202,8	151,3	5800 / 6525	400 / 450	40	18
MA 50	3,07	50,3	5000	5500	66,4	252	0,0405	0,80	207	280	224,7	167,6	5800 / 6525	400 / 450	40	18
MA 63	3,84	63,0	5000	5500	83,2	315	0,0508	1,00	259	351	281,5	210	5800 / 6525	400 / 450	40	18
MA 80	4,91	80,4	4500	5000	95,6	362	0,0648	1,28	330	448	323,3	241,2	5800 / 6525	400 / 450	51	23
MA 90	5,49	90,0	4500	5000	107,0	405	0,0725	1,43	370	501	361,9	270	5800 / 6525	400 / 450	51	23
MA 108	6,61	108,3	4000	4400	114,4	433	0,0877	1,72	445	603	387,3	288,8	5800 / 6525	400 / 450	51	23
MA 108R (2)	6,61	108,3	3400	4500	97,3	368	0,0877	1,72	445	603	329,2	245,5	5800 / 6525	400 / 450	77	35
MA 125	7,65	125,4	3400	4500	112,6	426	0,1010	2,00	515	699	381	284,2	5800 / 6525	400 / 450	77	35
MA 160	9,76	160,0	3600	4000	152,2	576	0,1289	2,55	657	891	514,7	384	5800 / 6525	400 / 450	107	48,5
MA 180	11,02	180,6	3600	4000	171,8	650	0,1455	2,87	742	1006	581	433,4	5800 / 6525	400 / 450	107	48,5
MA 250	15,27	250,2	2700	3000	178,5	676	0,2025	3,98	1028	1394	603,9	450,4	5800 / 6525	400 / 450	149,5	67,8

(1) For higher speeds, please contact us.

(2) The MA 108 R motor is in the frame size of the MA 125.

► Acceptable forces applied to motor shaft

Motor model		10	12	16	18	25	32	41	45	50	63	80	90	108	108 R	125	160	180	250
Fr	lbf	528	629	742	899	1349	1461	1574	1461	1686	2023	2360	2473	2585	2810	3260	4047	4496	4946
	N	2350	2800	3300	4000	6000	6500	7000	6500	7500	9000	10500	11000	11500	12500	14500	18000	20000	22000
Fa	lbf/psi	0.19	0.23	0.31	0.31	0.42	0.47	0.62	0.62	0.62	0.78	0.93	1.04	1.24	1.24	1.33	1.32	1.47	2.33
	N/psi	0.83	1.03	1.38	1.38	1.86	2.07	2.76	2.76	2.76	3.45	4.14	4.62	5.52	5.52	5.93	5.86	6.55	10.35
	(N/bar)*	(12)	(15)	(20)	(20)	(27)	(30)	(40)	(40)	(40)	(50)	(60)	(67)	(80)	(80)	(86)	(85)	(95)	(150)

Fr: radial force measured at mid point of length of shaft.

Fa: axial force which tends to push the shaft inwards.

\* Differential pressure between A and B.

For other forces, please contact us.

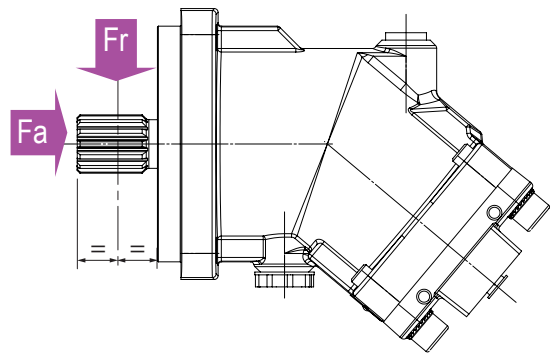
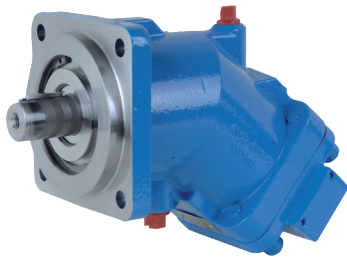

# Order code system of MA series motors

MA	...	...	...	...	U2	...	...	...	...	SP	To obtain the code for your motor, complete the different parameters 02, 03, 04, 05, 07, 08, 09 and 10 in the table on the left according to the options you require (see table below).											
01	02	03	04	05	06	07	08	09	10	11												
<b>Motor</b>																						
01	Motor											<b>MA</b>										
<b>Displacement</b>																						
02		10	12	16	18	25	32	41	45	50	63	80	90	108	108R	125	160	180	250			
<b>Mounting flange</b>																						
03		SAE B 2 bolts					SAE C 4 bolts					SAE D 4 bolts					-	<b>C</b>				
		-					-					-					SAE E 4 bolts	<b>C1</b>				
		-					-					-					SAE D 4 bolts	<b>C2</b>				
<b>Shaft</b>																						
04	Splined SAE J498b	13 T 16/32 DP	13 T 16/32 DP	13 T 16/32 DP	13 T 16/32 DP	14 T 12/24 DP	14 T 12/24 DP	14 T 12/24 DP	14 T 12/24 DP	14 T 12/24 DP	14 T 12/24 DP	14 T 12/24 DP	14 T 12/24 DP	14 T 12/24 DP	13 T 8/16 DP	13 T 8/16 DP	13 T 8/16 DP	13 T 8/16 DP	15 T 8/16 DP	<b>S1</b>		
		-	-	-	-	-	-	-	-	-	-	-	-	-	-	-	-	-	-	13 T 8/16 DP	<b>S2</b>	
		-	-	-	-	-	-	-	-	-	-	-	-	-	-	-	-	-	-	13 T 8/16 DP	<b>S3</b>	
	DIN 6885	-	-	-	-	-	-	-	-	-	-	-	-	-	-	-	Ø50 mm	Ø50 mm	-	<b>D1</b>		
Keyed SAE J744	Ø1"	Ø1"	Ø1"	Ø1"	Ø1 1/4"	Ø1 1/4"	Ø1 1/4"	Ø1 1/4"	Ø1 1/4"	Ø1 1/4"	Ø1 1/2"	Ø1 1/2"	-	Ø1 3/4"	Ø1 3/4"	-	-	Ø2"	<b>K1</b>			
	-	-	-	-	-	-	-	-	-	-	-	-	Ø1 1/4"	-	-	-	-	-	-	<b>K2</b>		
<b>Inlet ports A and B</b>																						
05	SAE flange ports	Bottom	0	-	-	-	-	•	•	•	•	•	•	•	•	•	•	•	•	•	<b>L0</b>	
		Rear	0	-	-	-	•	•	•	•	•	•	•	•	•	•	•	•	•	•	•	<b>M0</b>
		Side	0	-	-	-	•	•	•	•	•	•	•	•	-	•	•	•	•	•	•	<b>N0</b>
	1		-	-	-	•	•	•	•	•	•	•	•	•	•	•	•	•	•	•	•	<b>N1</b>
	Threaded	Side	0	•	•	•	•	•	•	-	-	-	-	-	-	-	-	-	-	-	-	<b>Q0</b>
			1	-	-	-	•	•	•	-	-	-	-	-	-	-	-	-	-	-	-	<b>Q1</b>
Rear		0	•	•	•	•	•	•	•	-	-	-	-	-	-	-	-	-	-	-	<b>P0</b>	
<div style="border: 1px solid red; padding: 2px; display: inline-block;">           0 = Without suitability for valves            1 = Compatible with flushing valve         </div>																						
<b>Drain ports T1 and T2</b>																						
06		2	2	2	2	2	2	2	2	2	2	2	2	2	2	2	2	2	2	2	<b>U2</b>	
<b>Suitable for use of speed sensor</b>																						
07	Yes	•	•	•	•	•	•	•	•	•	•	•	•	•	•	•	•	•	•	•	<b>1</b>	
	No	•	•	•	•	•	•	•	•	•	•	•	•	•	•	•	•	•	•	•	•	<b>0</b>
<b>Speed sensor</b>																						
08	1 frequency signal	•	•	•	•	•	•	•	•	•	•	•	•	•	•	•	•	•	•	•	<b>1</b>	
	1 signal with connector	•	•	•	•	•	•	•	•	•	•	•	•	•	•	•	•	•	•	•	<b>1P</b>	
	2 signals with connector	○	•	•	•	•	•	•	•	•	•	•	•	•	•	•	•	•	•	•	<b>2P</b>	
	No	•	•	•	•	•	•	•	•	•	•	•	•	•	•	•	•	•	•	•	•	<b>0</b>
<b>Flushing valve</b>																						
09	Without	•	•	•	•	•	•	•	•	•	•	•	•	•	•	•	•	•	•	•	<b>SV</b>	
	Flow rate	4,25 l/min*	-	-	-	-	•	•	•	•	•	•	•	•	•	•	•	•	•	•	-	<b>VB04</b>
		10 l/min*	-	-	-	-	•	•	•	•	•	•	•	•	•	•	•	•	•	•	•	<b>VB10</b>
		14 l/min*	-	-	-	-	•	•	•	•	•	•	•	•	•	•	•	•	•	•	•	<b>VB14</b>
<b>Low temperature option</b>																						
10	Yes (NBR)	-	•	•	•	•	•	•	•	•	•	•	•	•	•	•	•	•	•	•	<b>N</b>	
	No (FKM)	•	•	•	•	•	•	•	•	•	•	•	•	•	•	•	•	•	•	•	<b>F</b>	

## Legend:

- Existing model
- On request
- Not available

\*( $\Delta p = 25$  bar)

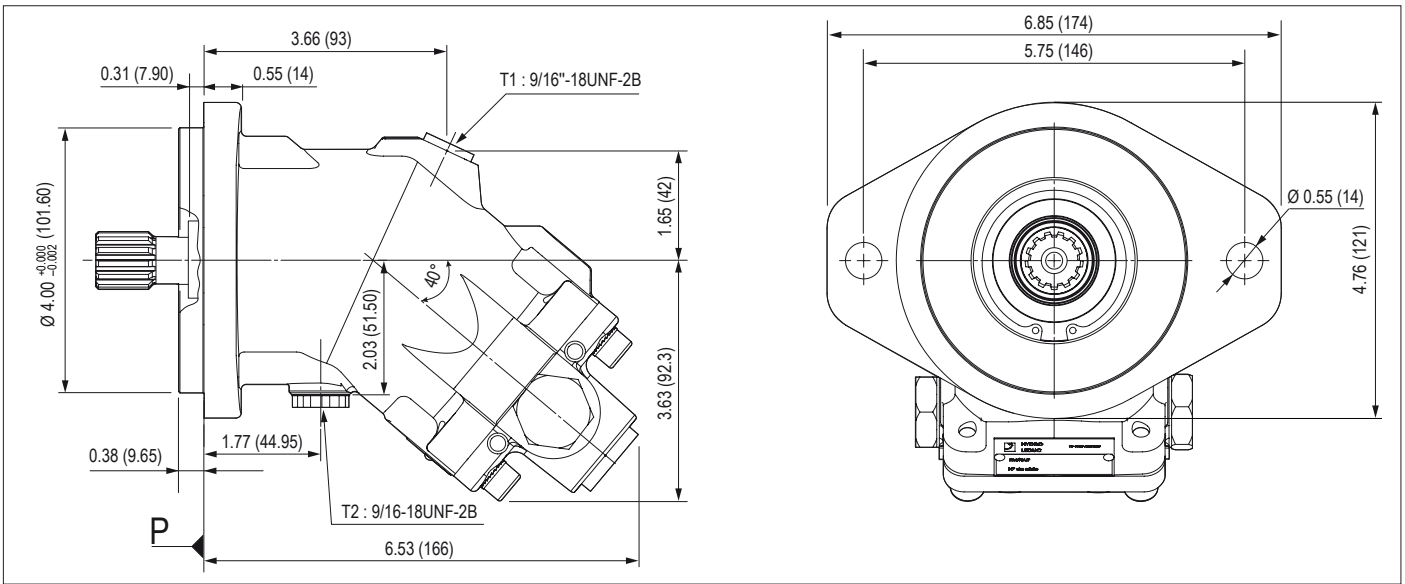

► Shaft end

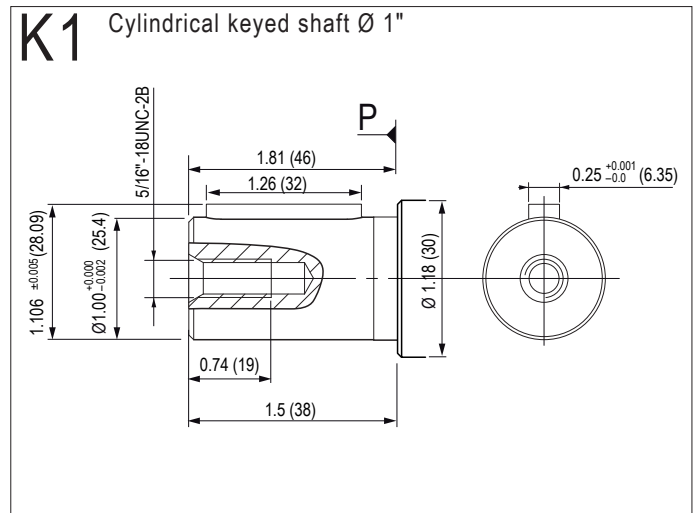
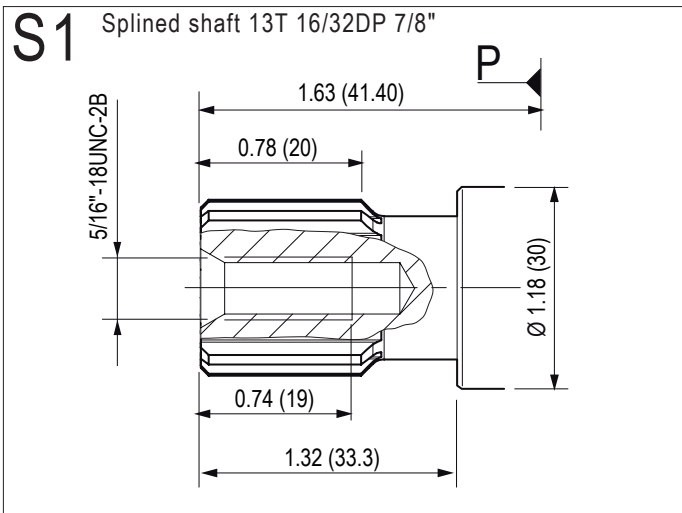

► Inlet ports

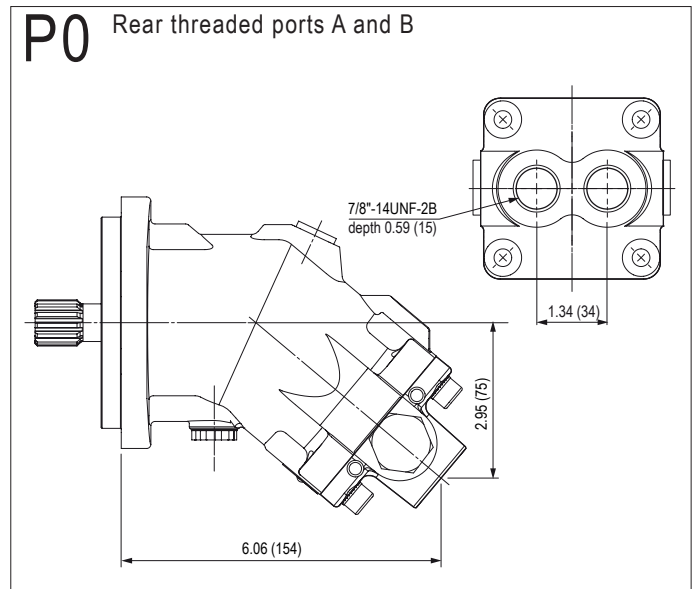
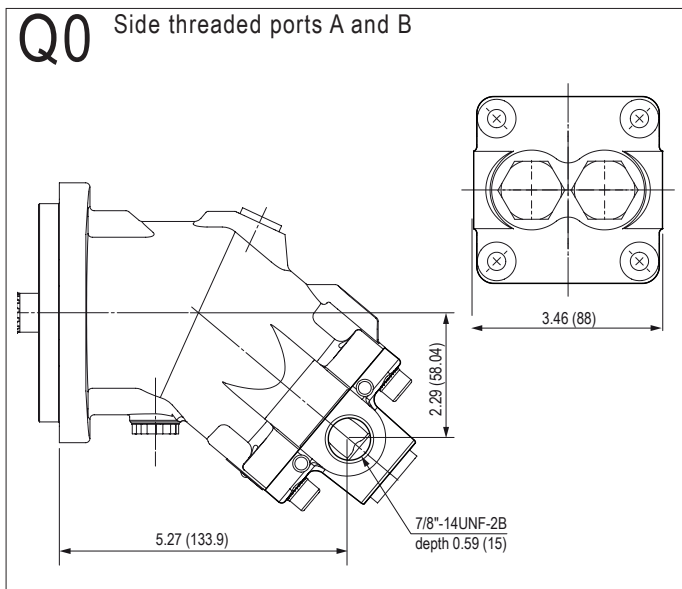

Dimensions in inches (mm) are given only as an indication.

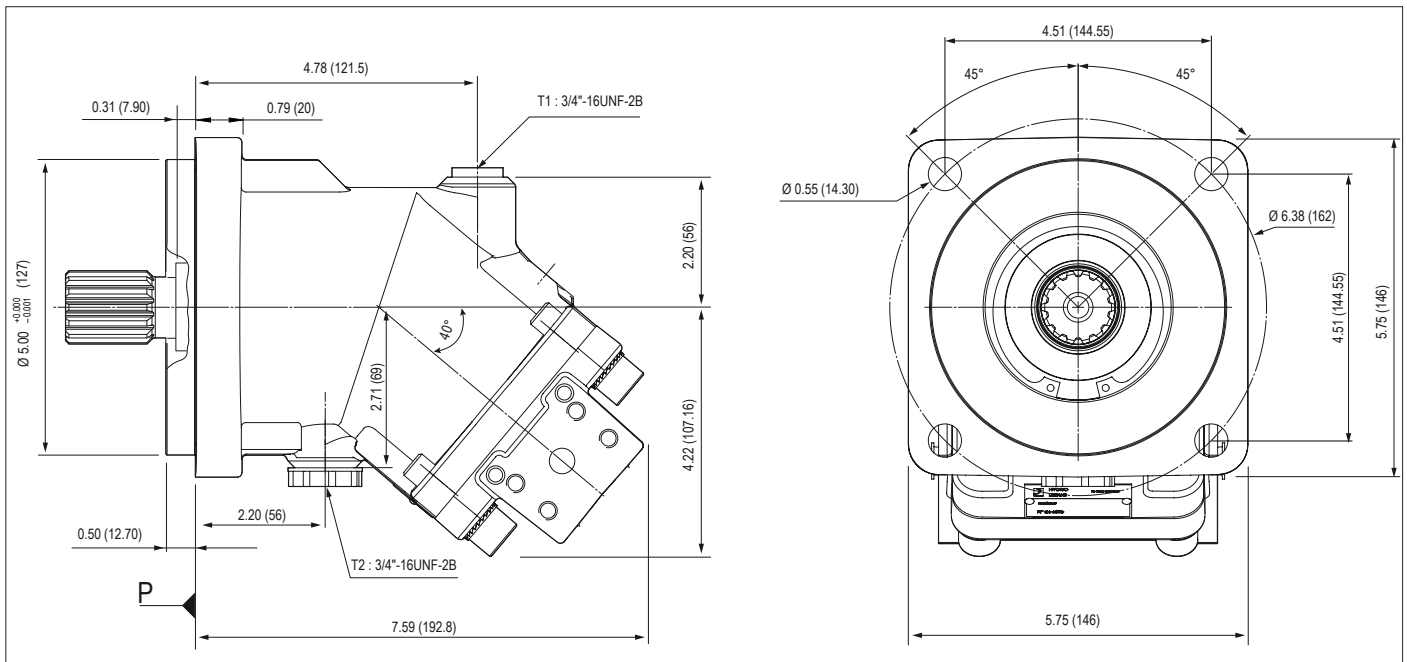

### ► Shaft end

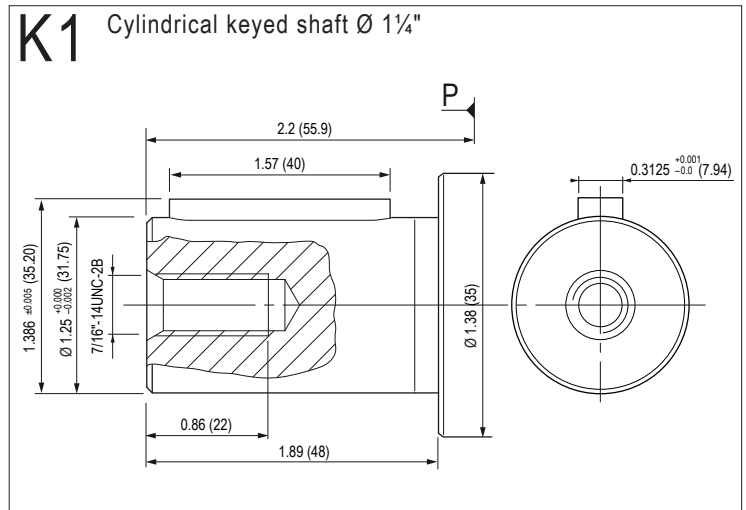
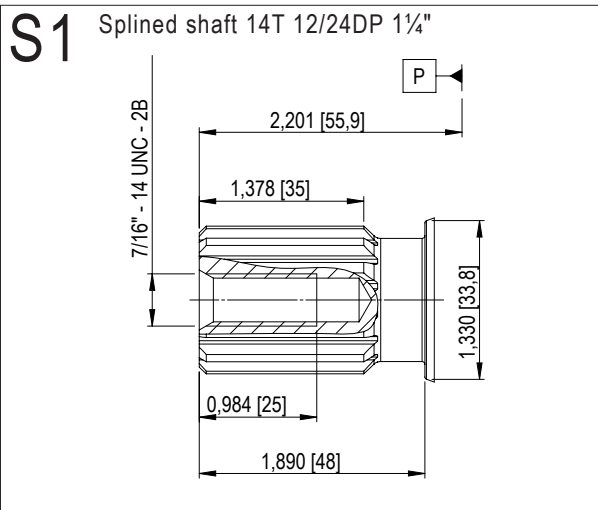



► Shaft end

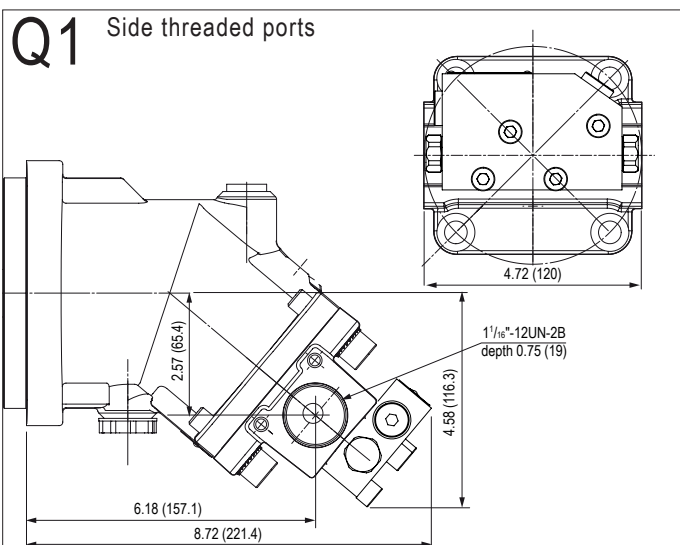
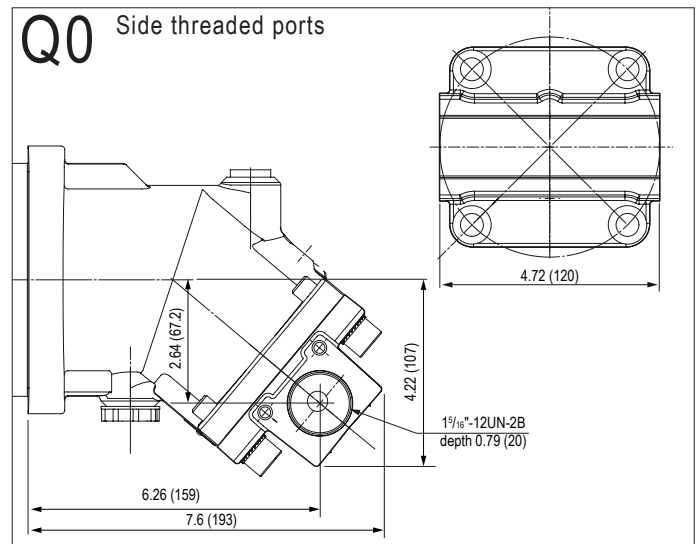
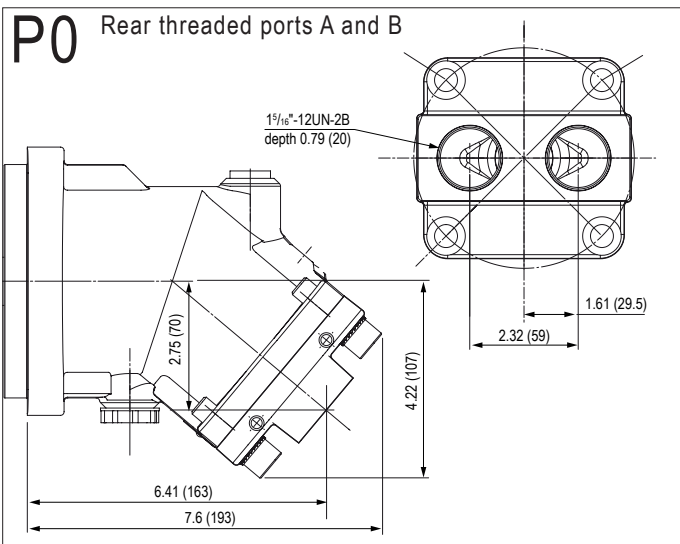
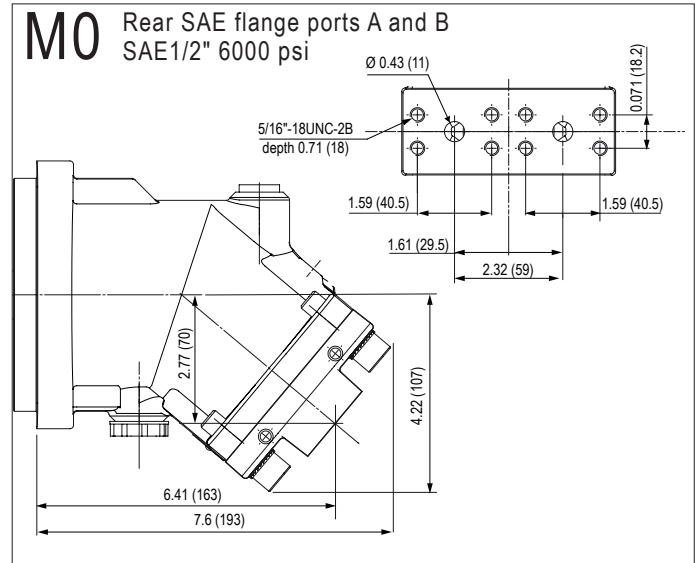
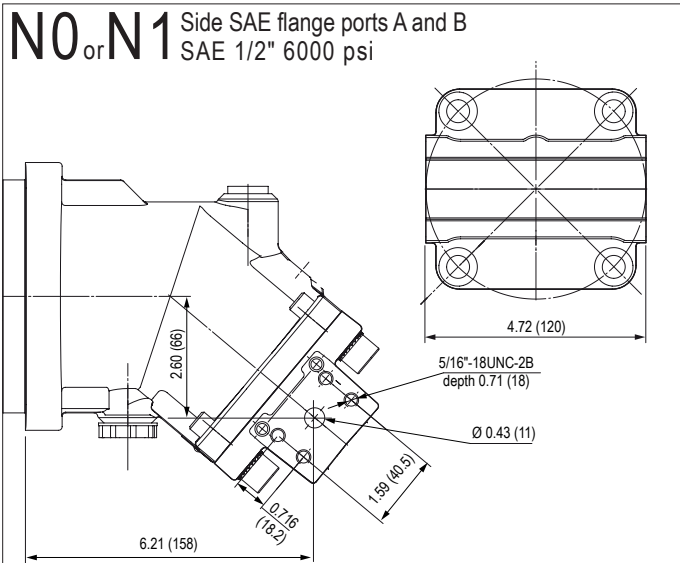

Dimensions in inches (mm) are given only as an indication.

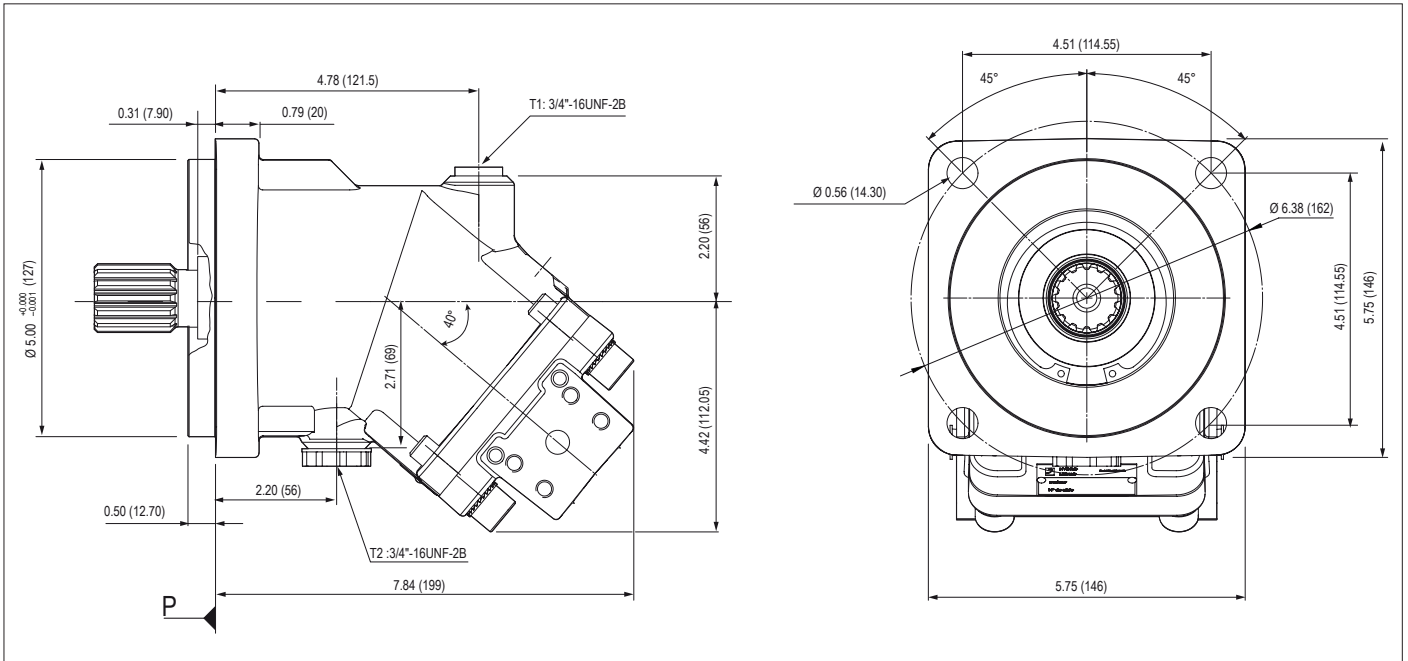

► Shaft end

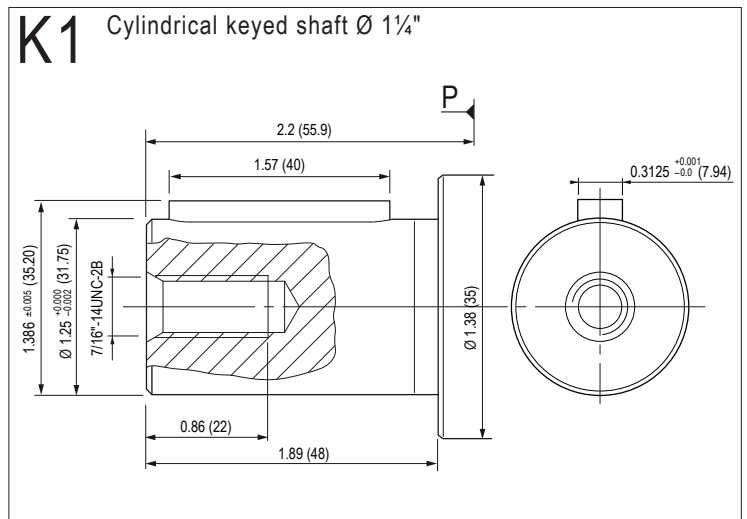
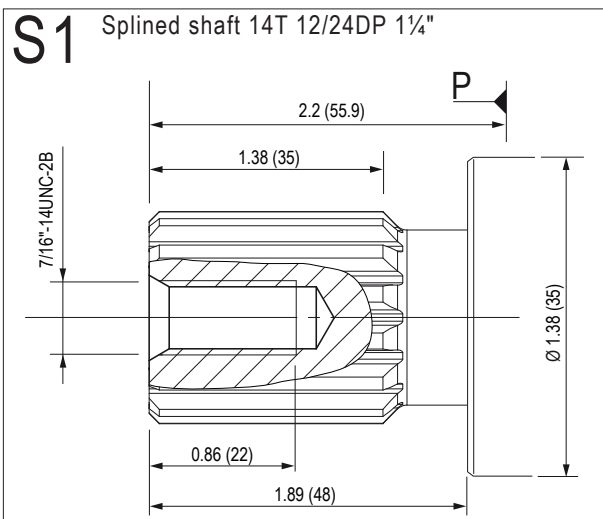

► Inlet ports

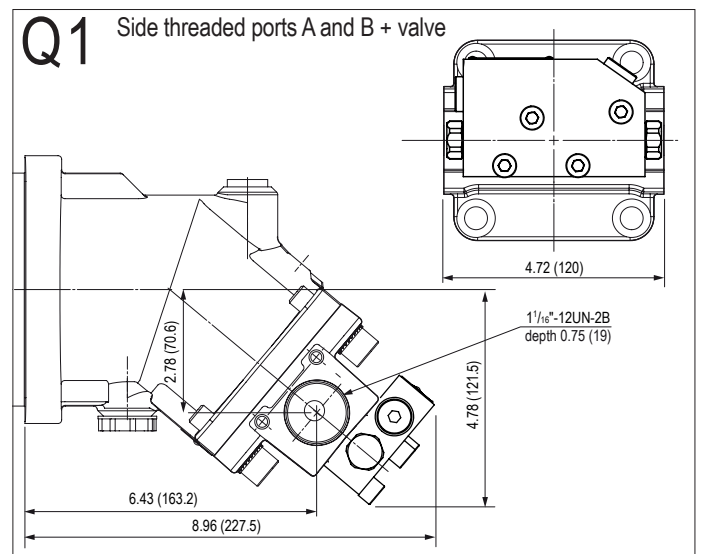
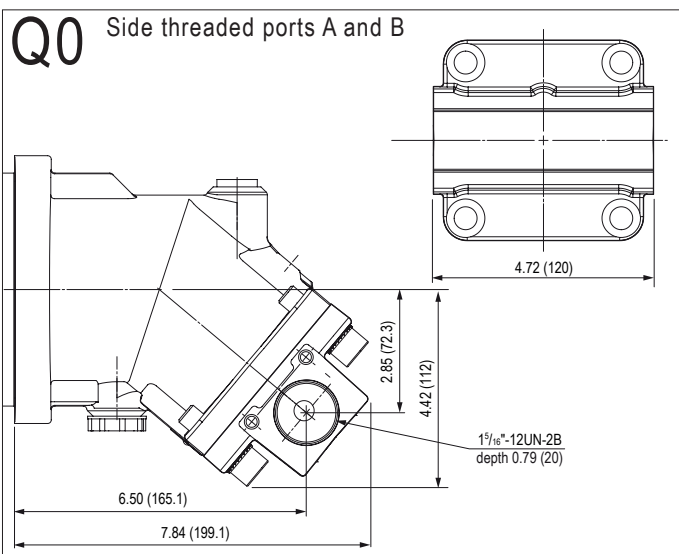
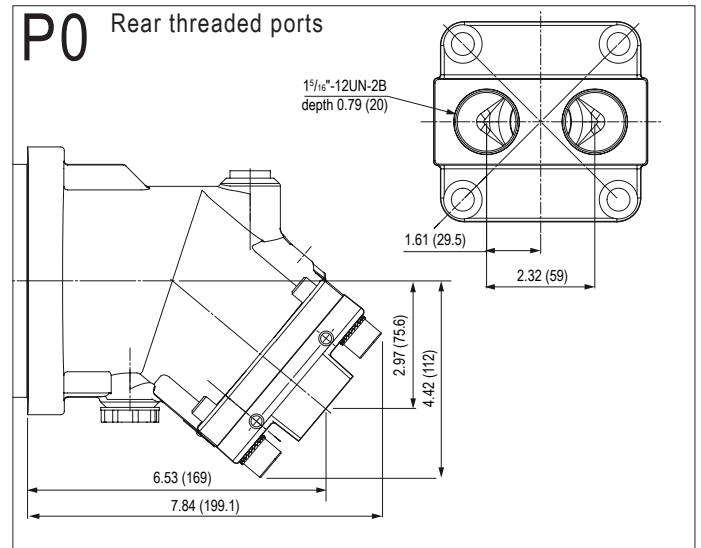
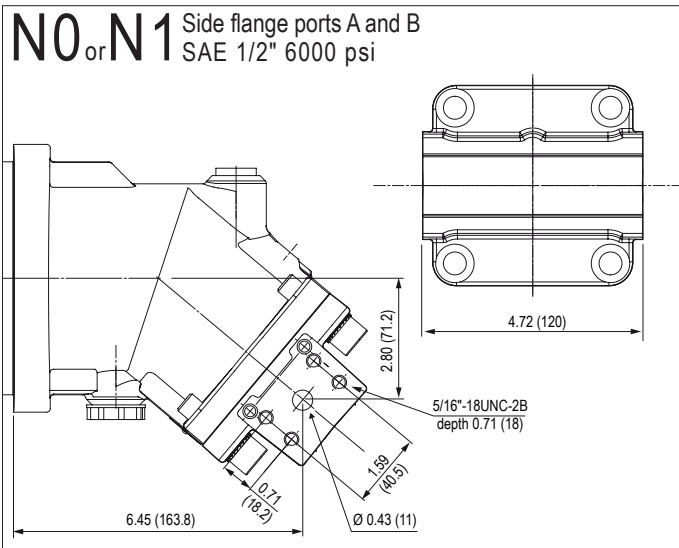
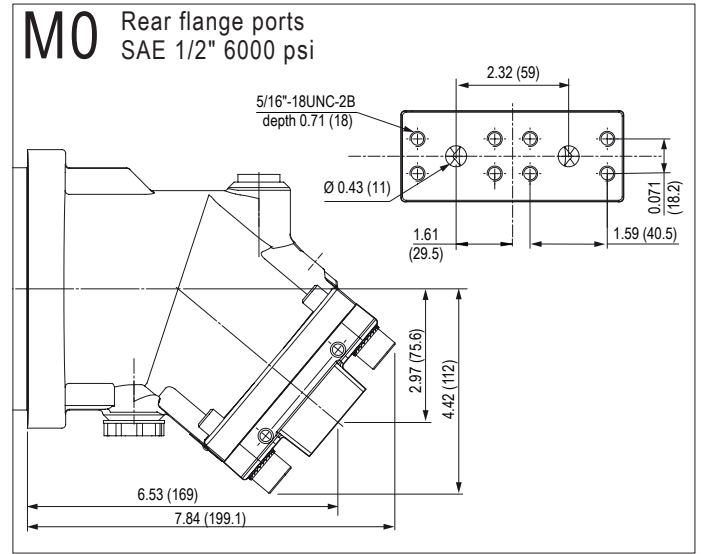
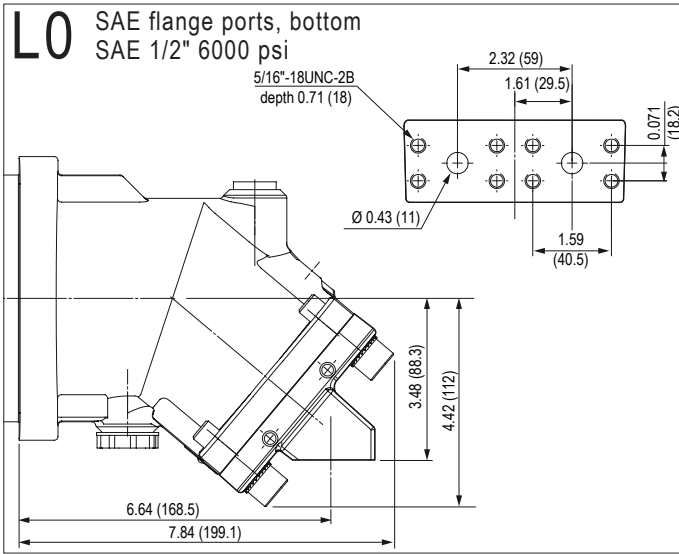

Dimensions in inches (mm) are given only as an indication.

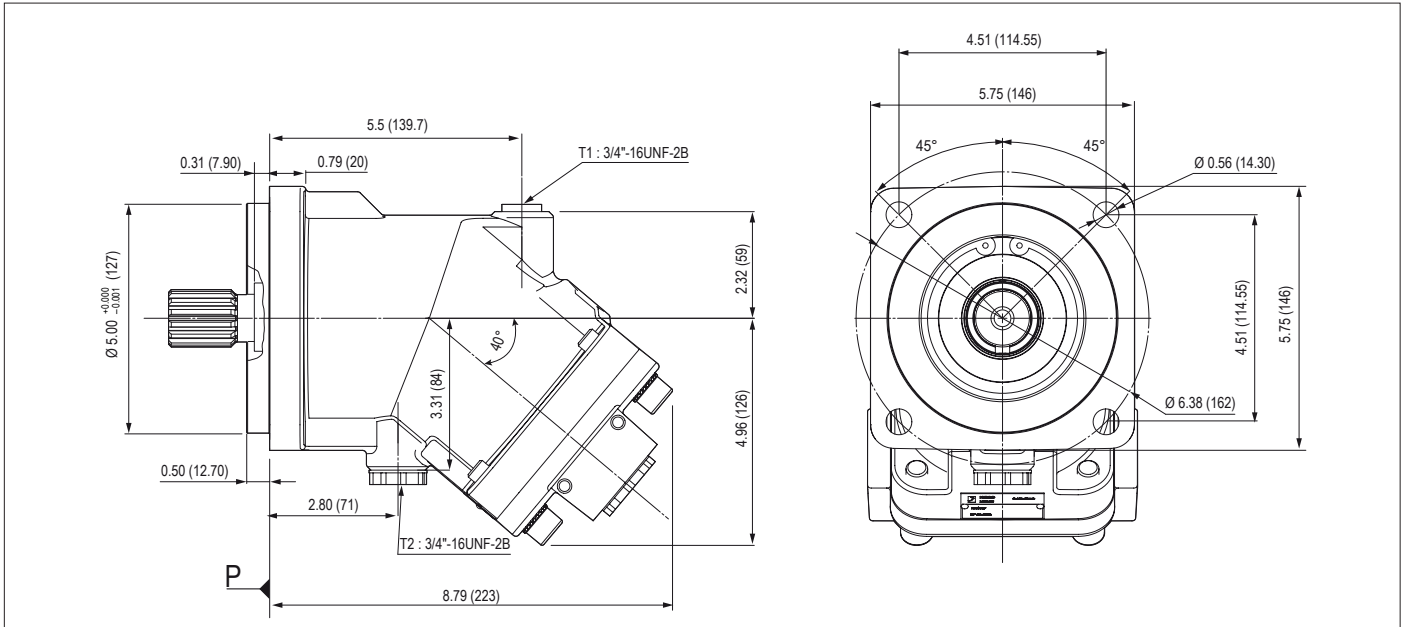

### ► Shaft end

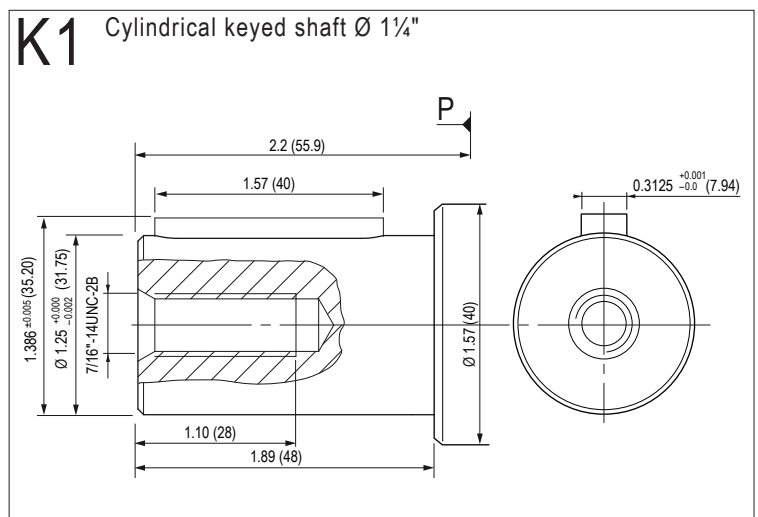
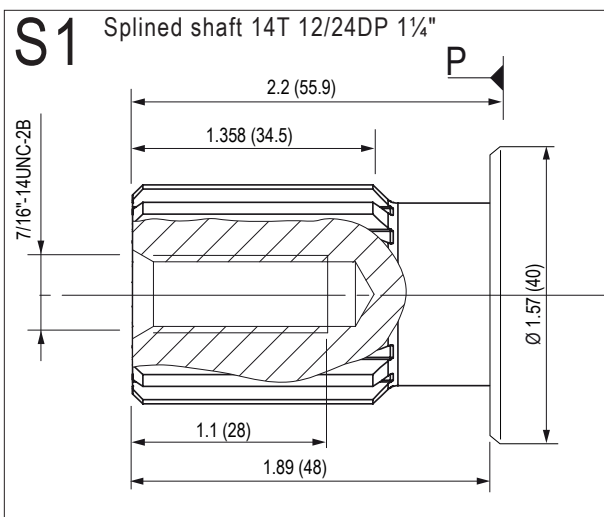

► Inlet ports

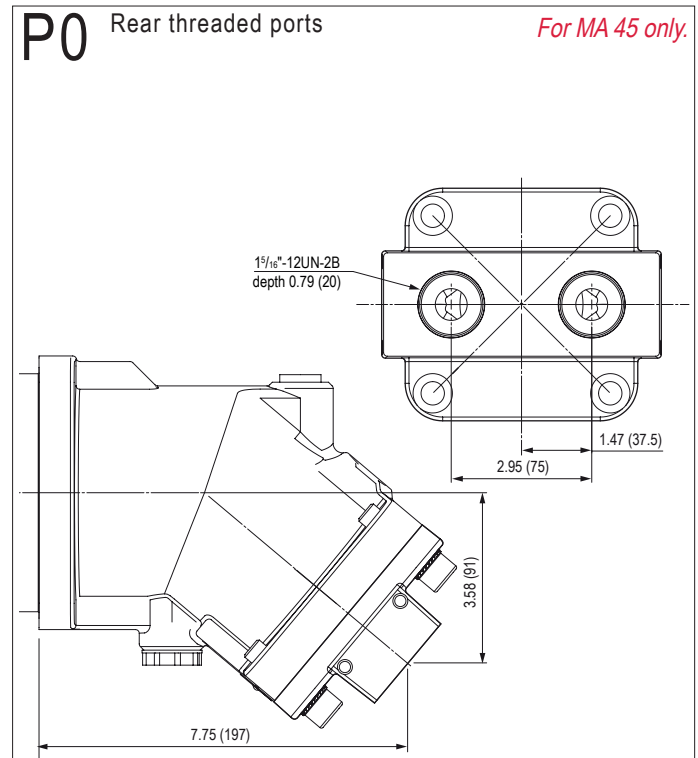
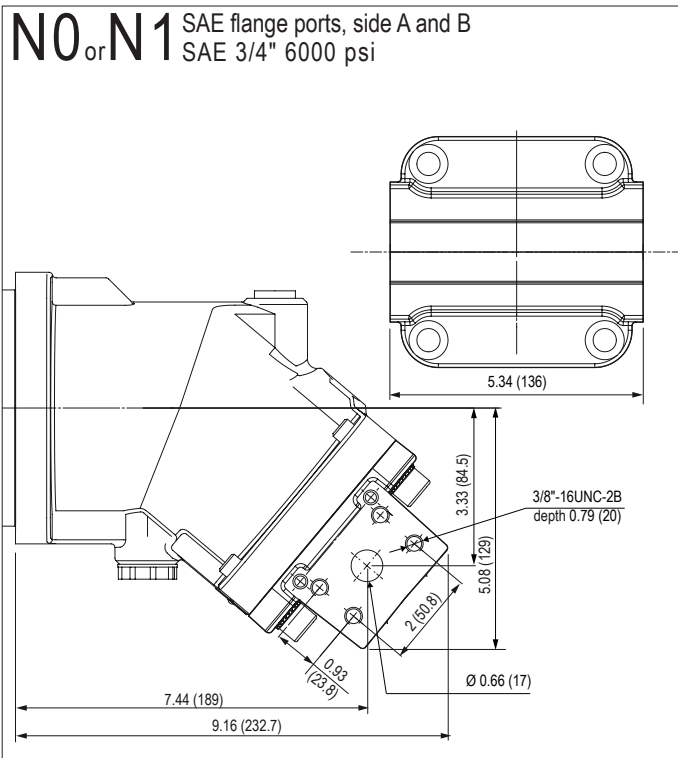
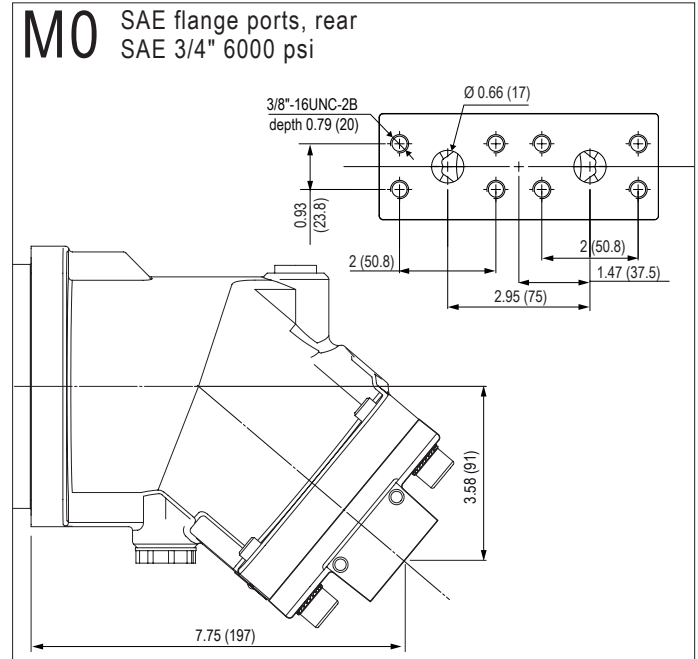
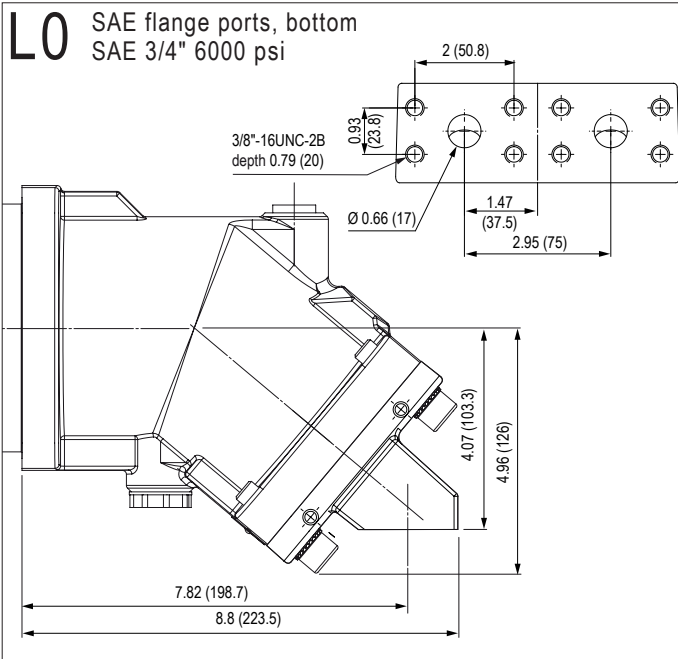

MA series

Dimensions in inches (mm) are given only as an indication.

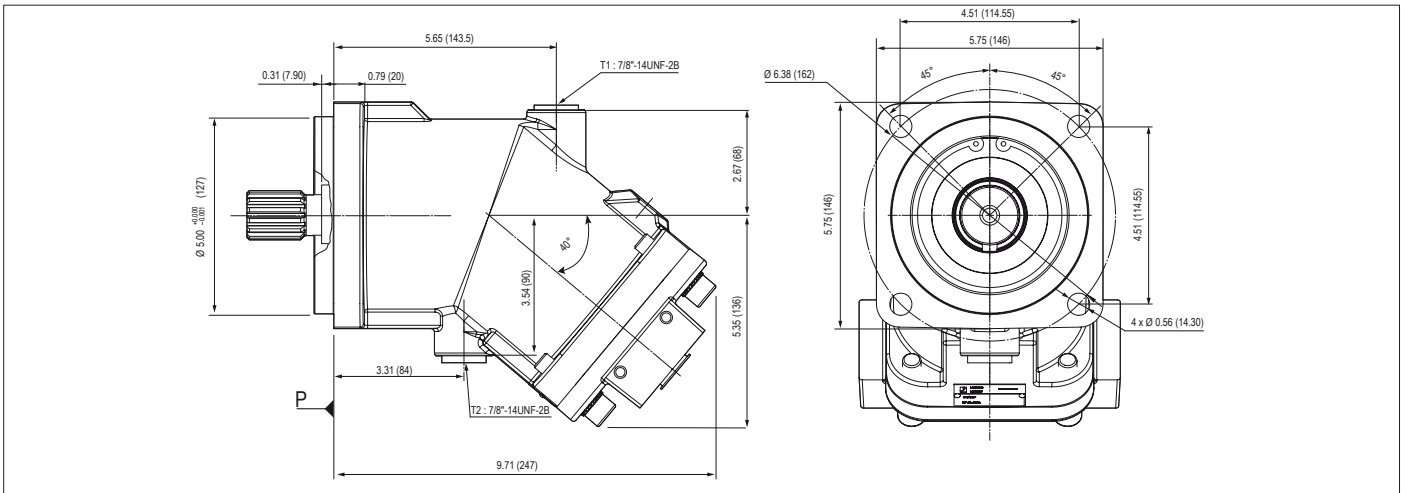

► Shaft end

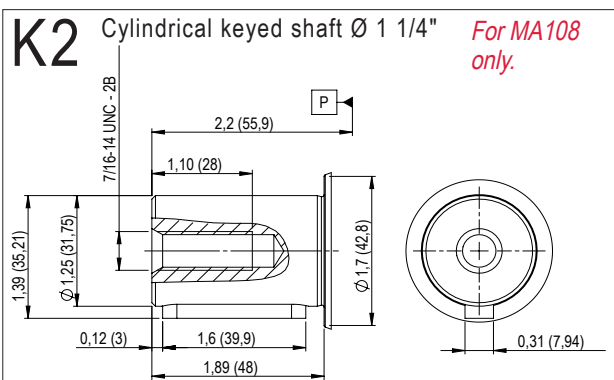
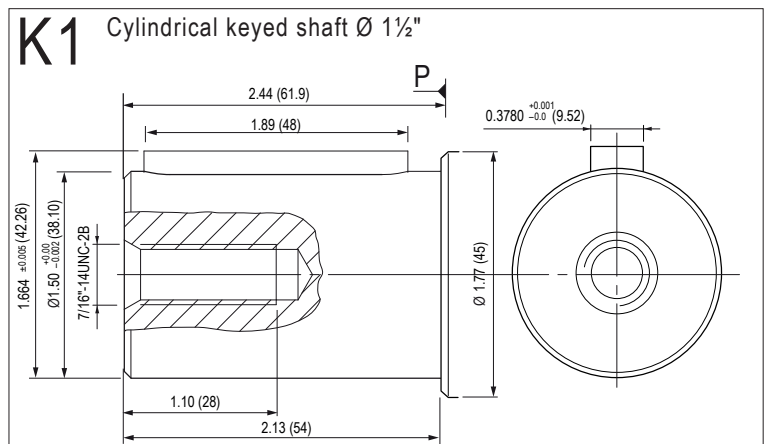
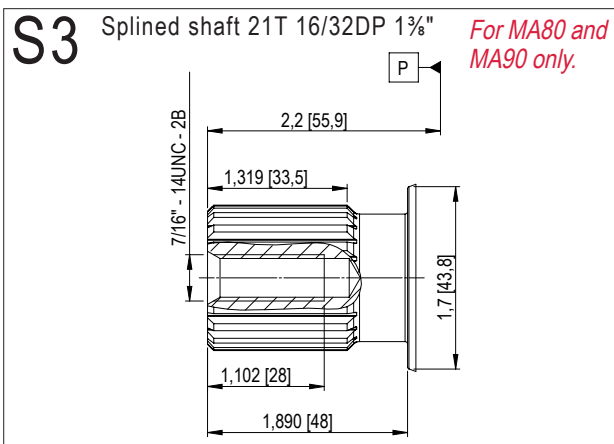
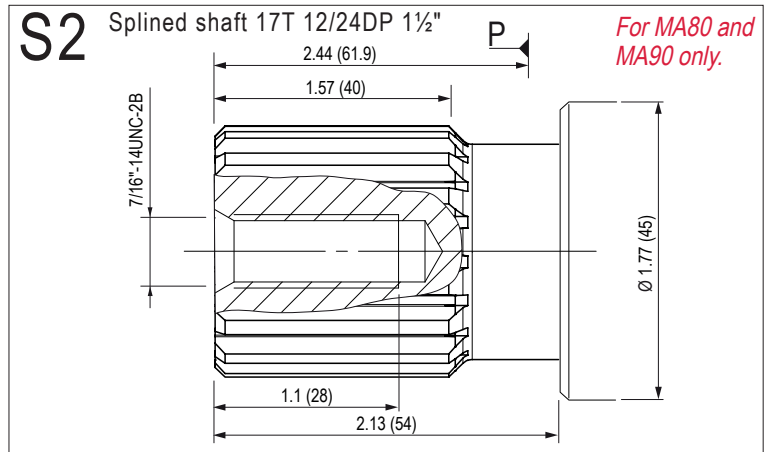
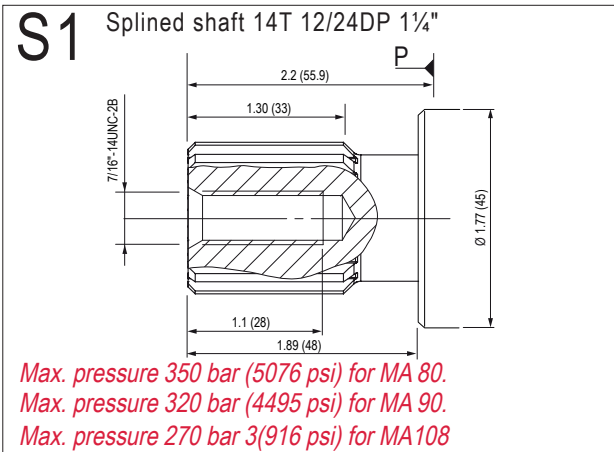

Dimensions in inches (mm) are given only as an indication.

► Inlet ports

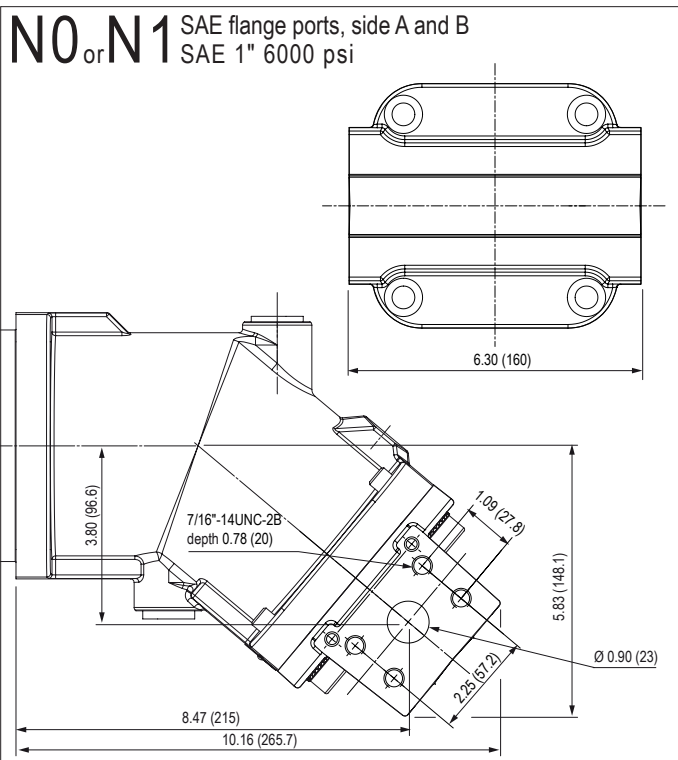
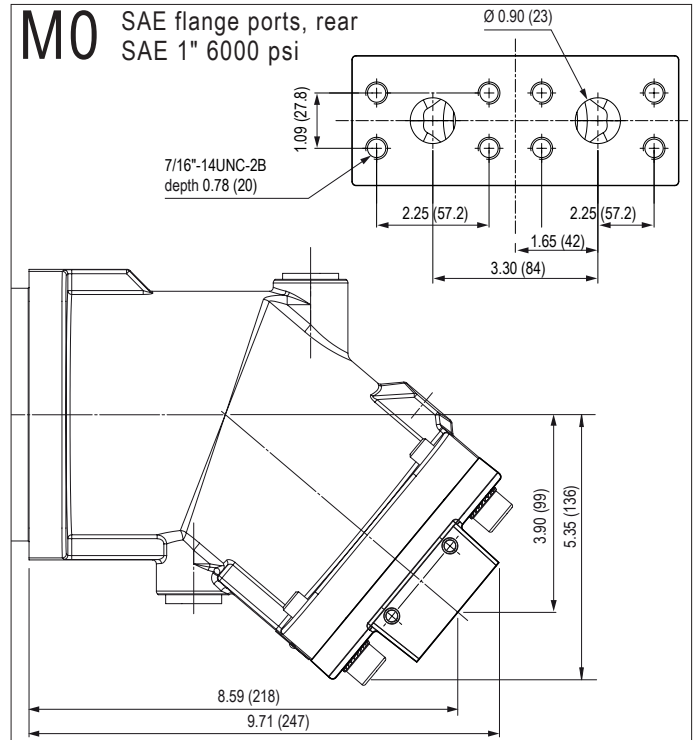
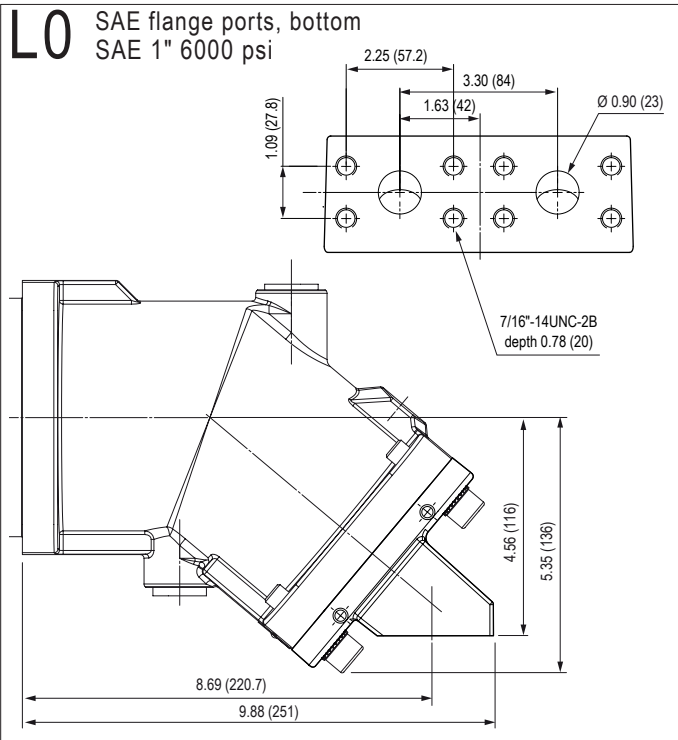

MA series

Dimensions in inches (mm) are given only as an indication.

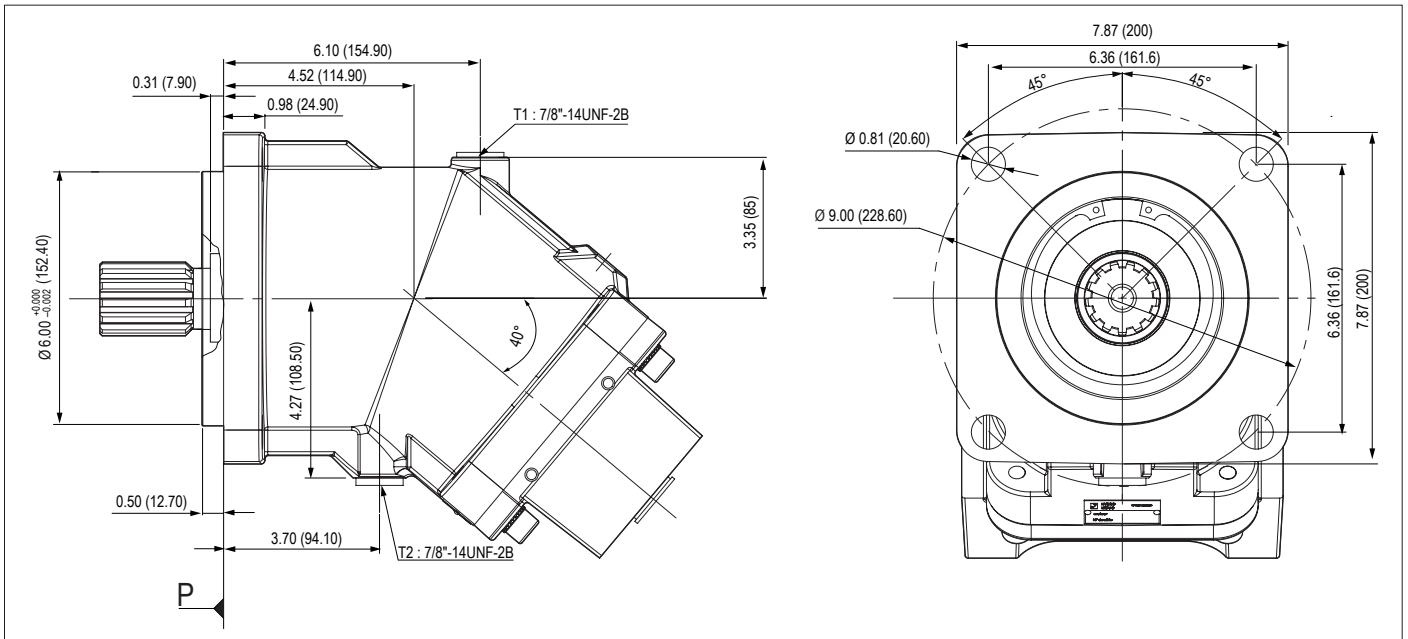

### ► Shaft end

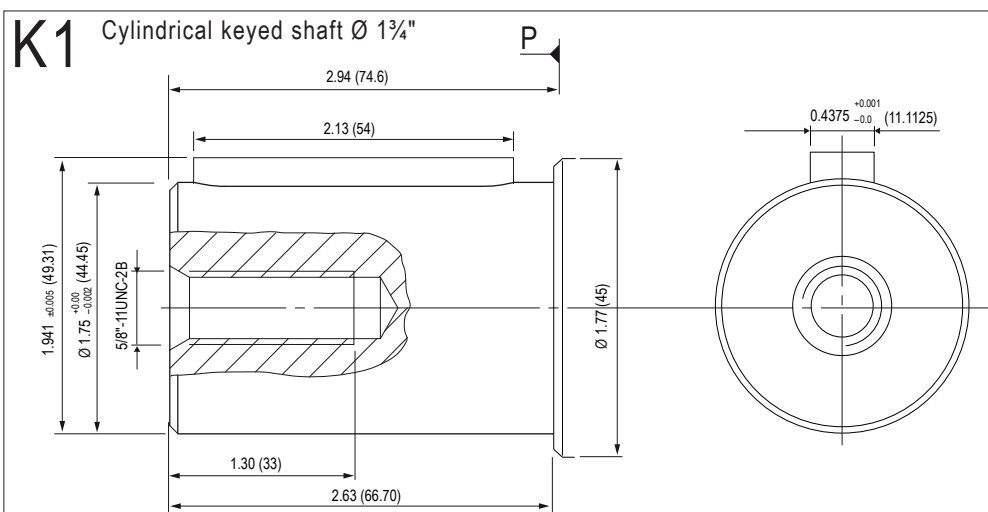
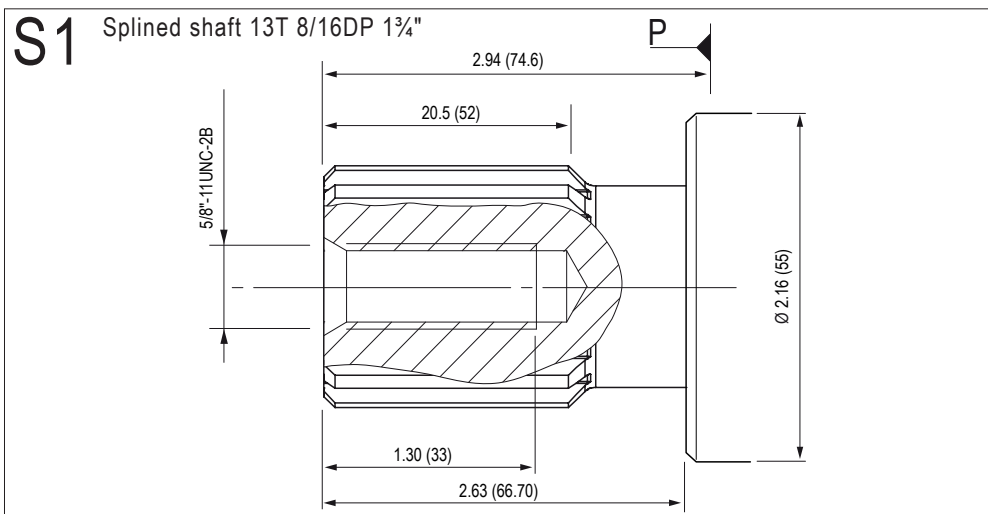

Dimensions in inches (mm) are given only as an indication.



► Inlet ports

**L0** SAE flange ports, bottom  
SAE 1 1/4" 6000 psi

	MA 108R	MA 125
A	10.66 (270.9)	10.75 (273.2)
B	9.33 (236.9)	9.42 (239.2)
C	5.76 (146.3)	5.84 (148.2)
D	4.64 (117.8)	4.71 (119.7)

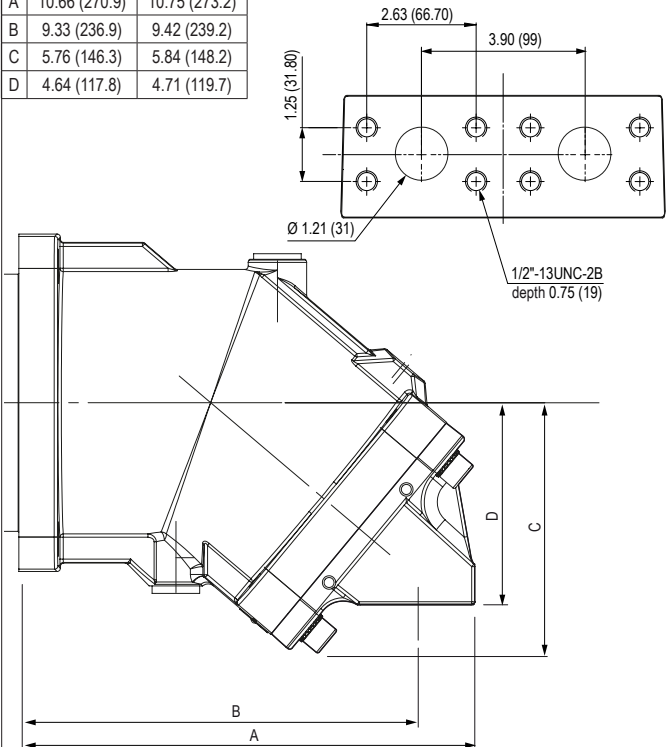

**M0** SAE flange ports, rear  
SAE 1 1/4" 6000 psi

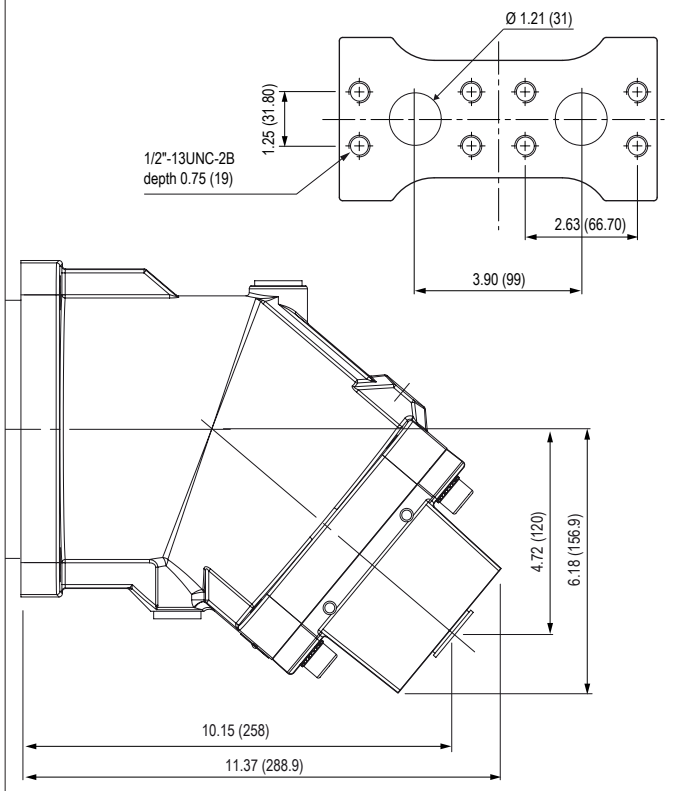

**N0 or N1** SAE flange ports, side A and B  
SAE 1 1/4" 6000 psi

	MA 108R	MA 125
A	11.35 (288.4)	11.52 (292.7)
B	9.16 (232.7)	9.25 (235)
C	6.14 (156)	6.30 (159.9)
D	3.89 (98.9)	3.97 (100.8)

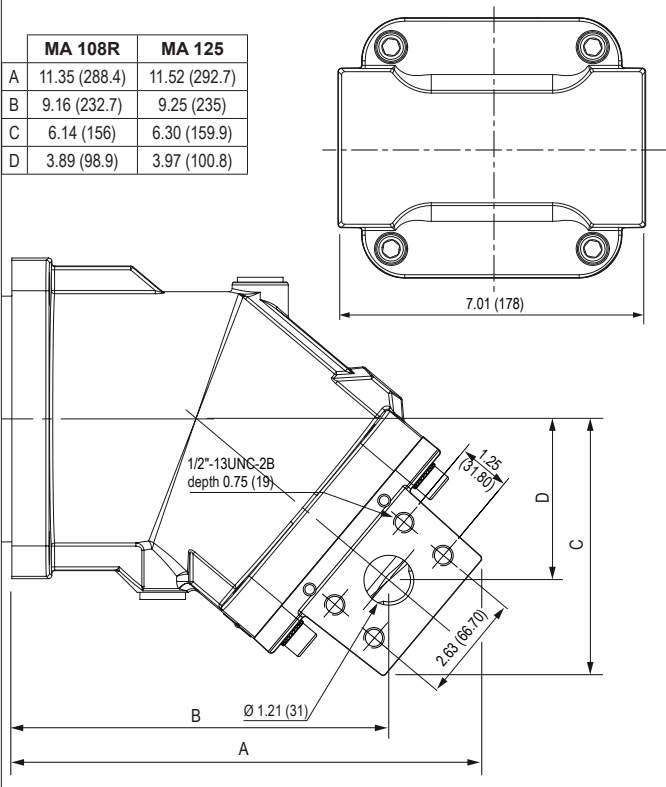

Dimensions in inches (mm) are given only as an indication.

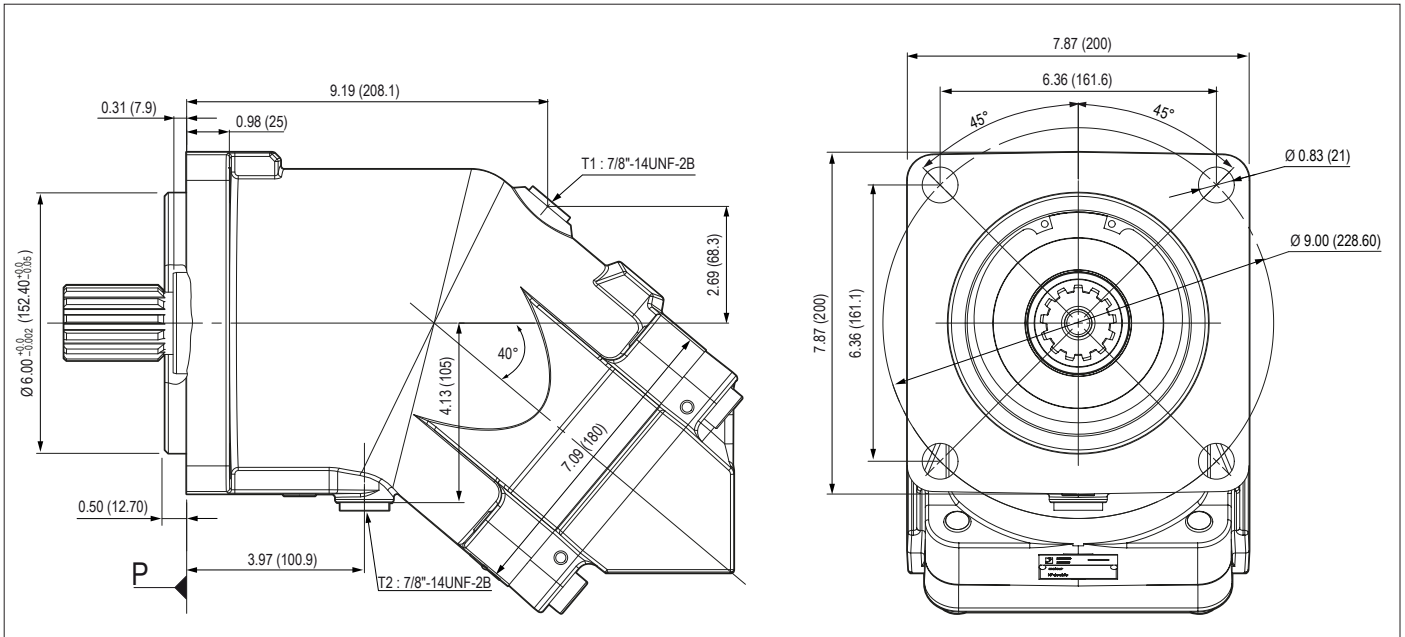

### ► Shaft end

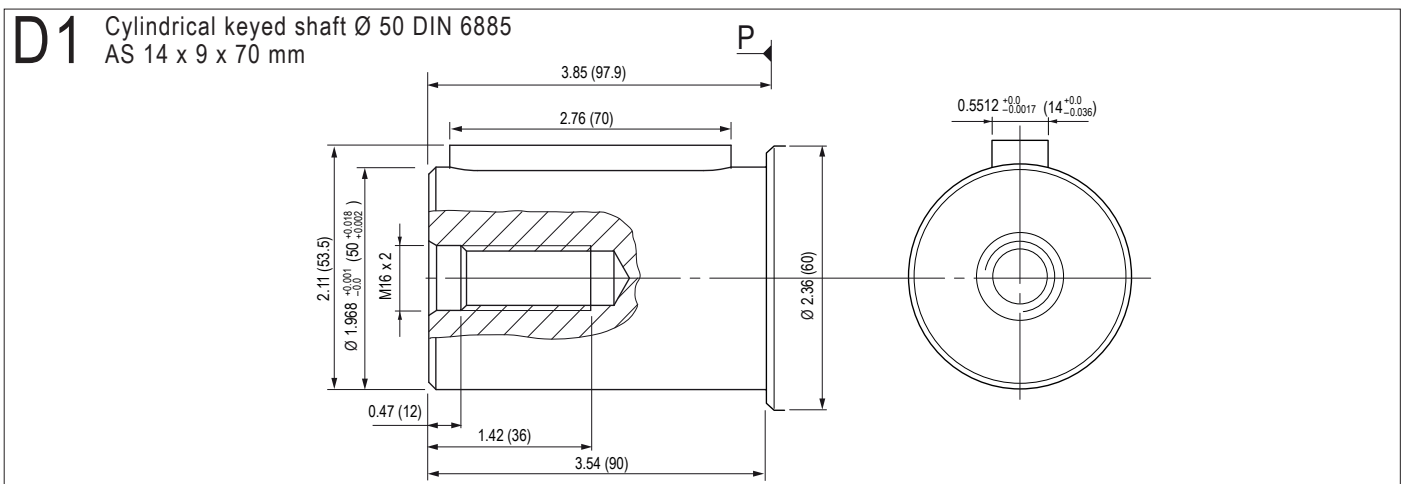
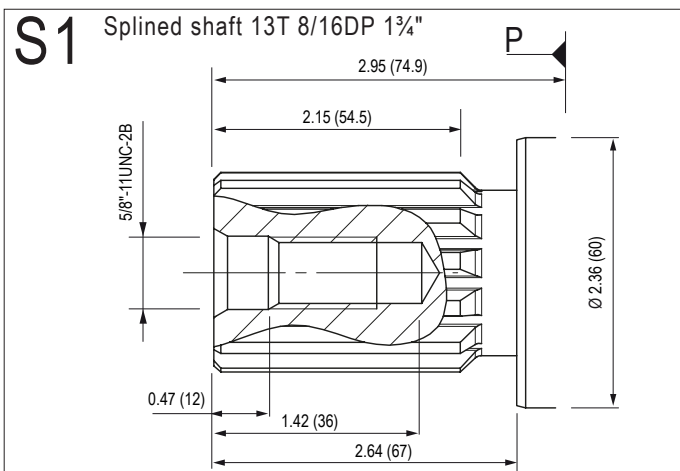

► Inlet ports

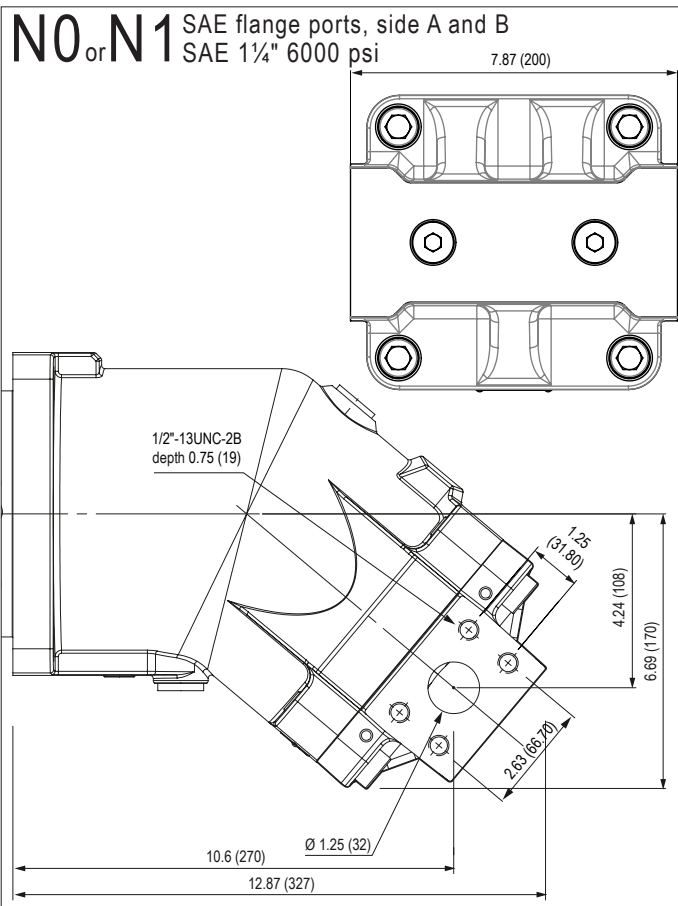
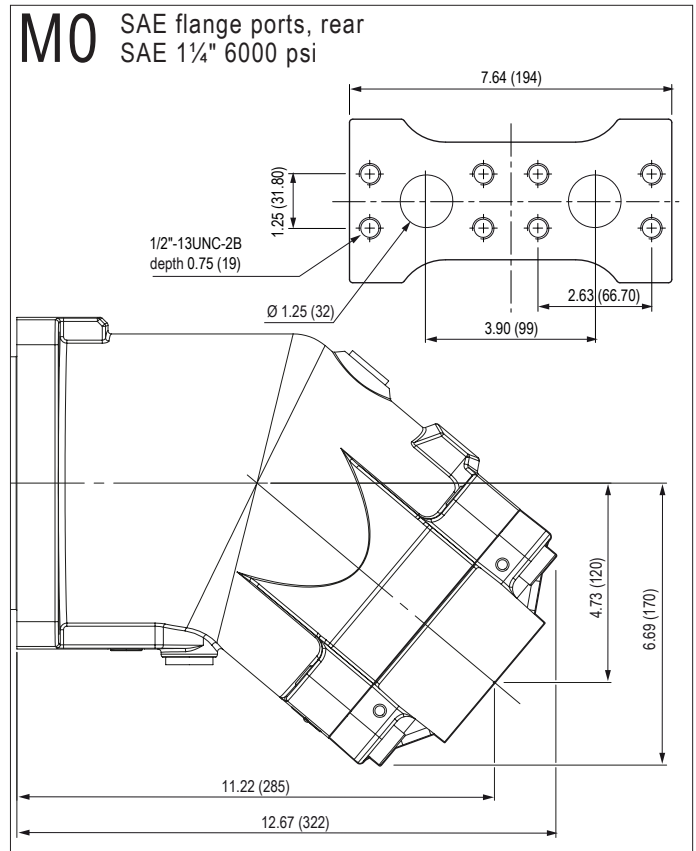
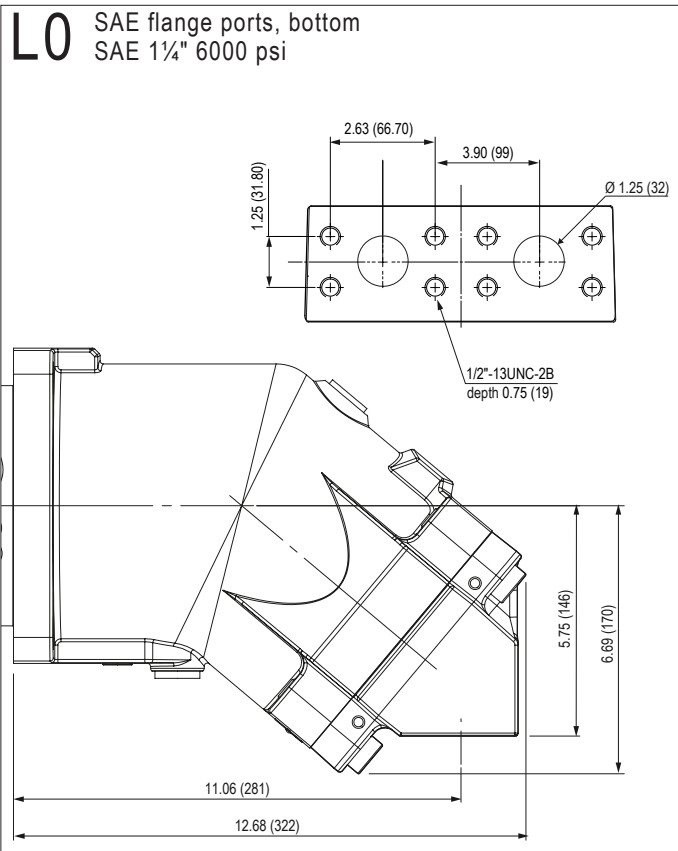

Dimensions in inches (mm) are given only as an indication.

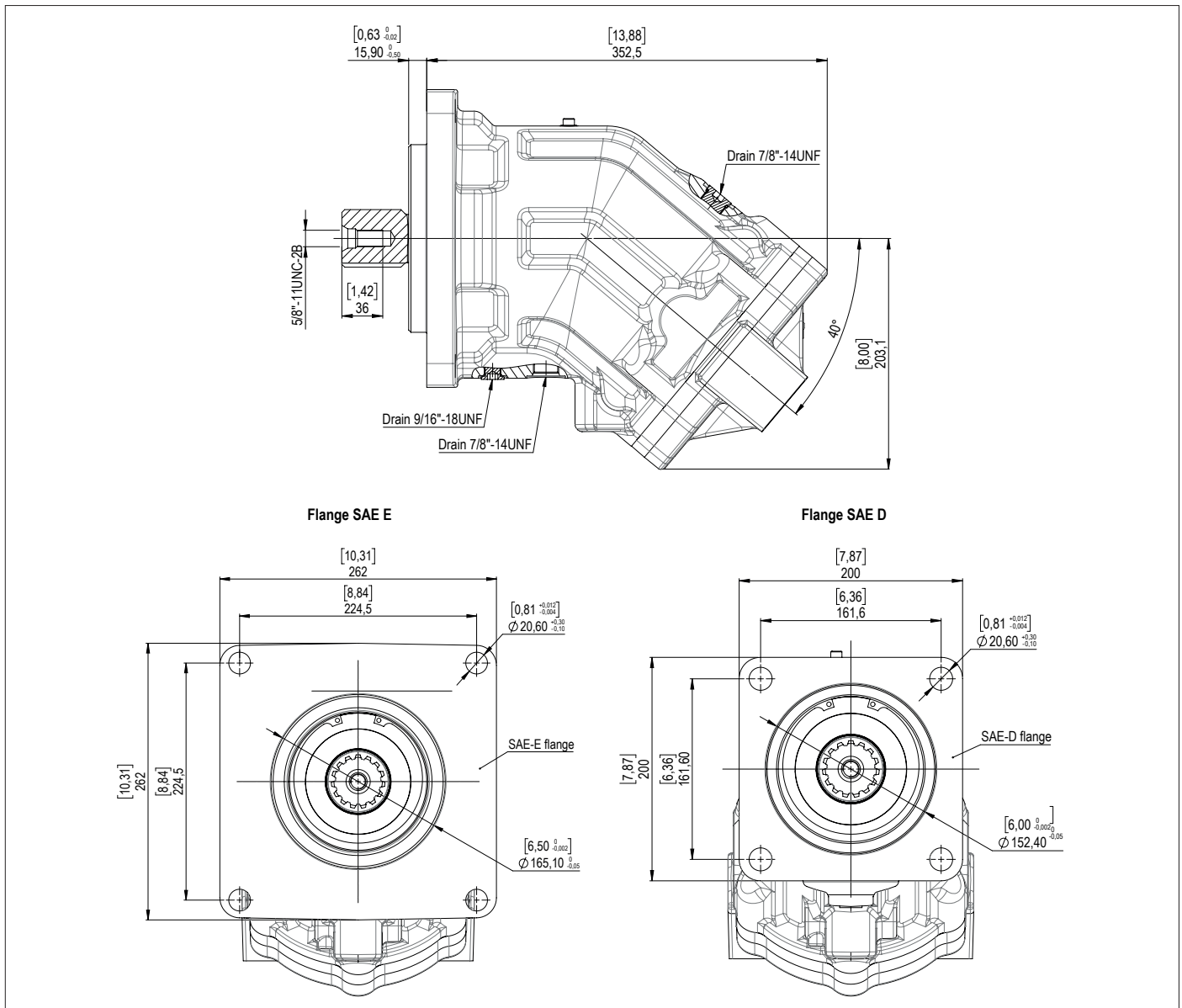

### ► Shaft end

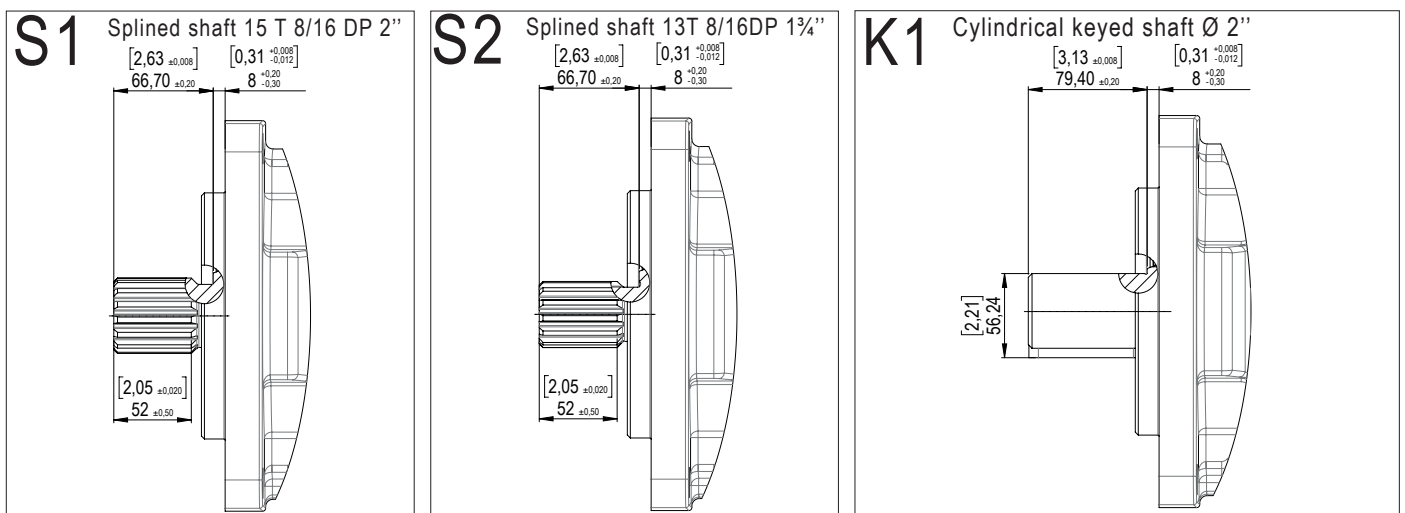

Dimensions in inches (mm) are given only as an indication.



## CHARACTERISTICS OF THE MSI SERIES MOTORS

Motor model	Displacement (cc/rev)	Continuous max. speed (1) (rpm)	Intermittent max. speed (1) (rpm)	Max. flow absorbed (l/mn)	Torque (N.m/bar)	Torque at 350 bar (N.m)	Max. allowable pressure continuous / peak (bar)	Weight (kg)
MSI 28	27,7	6300	6900	175	0,44	154	400 / 450	11,5
MSI 32	32,1	6300	6900	202	0,51	179	400 / 450	11,5
MSI 41	41,1	5600	6200	230	0,65	229	400 / 450	11,5
MSI 45	45,4	5000	5500	227	0,72	253	400 / 450	17
MSI 50	50,3	5000	5500	252	0,80	280	400 / 450	19
MSI 63	63,3	5000	5500	315	1,00	351	400 / 450	19
MSI 80	80,4	4500	5000	362	1,28	448	400 / 450	26
MSI 90	90	4500	5000	405	1,43	501	400 / 450	26
MSI 108	108,3	4000	4400	433	1,72	603	400 / 450	26
MSI 108 R (2)	108,3	3400	4500	368	1,72	603	400 / 450	33
MSI 125	125,3	3400	4500	426	2,00	699	400 / 450	33
MSI 160	160,3	3600	4000	576	2,55	891	400 / 450	45,3
MSI 180	180,3	3600	4000	650	2,87	1006	400 / 450	45,3

(1) For higher speeds, please contact us.

(2) The MSI 108 R is in the frame size of the MA 125.

## ► Acceptable forces applied to motor shaft

Motor model	28	32	41	45	50	63	80	90	108	108 R	125	160	180	
Fr	N	6200	6500	7000	6500	7500	9000	10500	11000	11500	12500	14500	18000	20000
Fa	N/bar *	28	30	40	40	40	50	60	67	80	80	86	85	95

Fr: radial force measured at mid point of length of shaft.

Fa: axial force which tends to push the shaft inwards.

\* Differential pressure between A and B.

For other forces, please contact us.

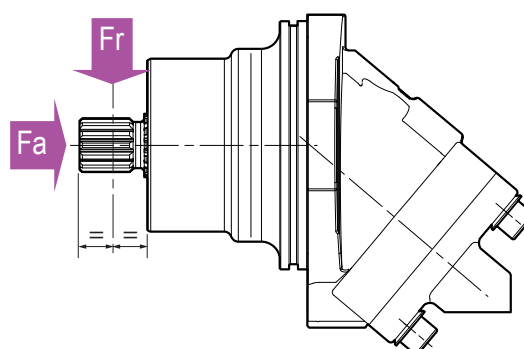
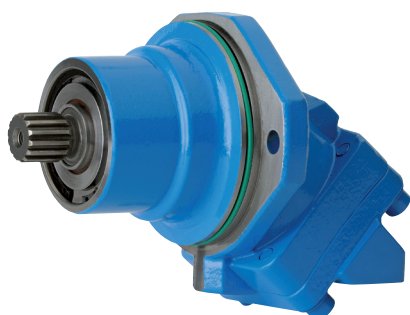

MSI	...	B	...	...	M1	...	...	...	...	SP
01	02	03	04	05	06	07	08	09	10	11

To obtain the code for your motor, complete the different parameters 02, 04, 05, 07, 08, 09 and 10, in the table on the left according to the options you require (see table below).

Motor																
<b>01</b>	Semi-integrated motor															<b>MSI</b>
Displacement																
<b>02</b>			28	32	41	45	50	63	80	90	108	108 R	125	160	180	
Mounting flange																
<b>03</b>	2 bolts ISO 3019-2															<b>B</b>
Shaft																
<b>04</b>	DIN 5480 splined	W30	W30	W30	W30	W30	W30	W40	W40	W40	W45	W45	W50	W50	<b>W1</b>	
		W25	W25	-	W35	W35	W35	W35	W35	W35	-	W40	W40	-	-	<b>W2</b>
	DIN 6885 keyed	Ø30	Ø30	Ø30	Ø30	Ø30	Ø30	Ø40	Ø40	Ø40	Ø45	Ø45	Ø50	Ø50	<b>D1</b>	
		Ø25	Ø25	-	Ø35	Ø35	Ø35	-	-	-	Ø40	-	-	-	<b>D2</b>	
Inlet ports A and B																
<b>05</b>	SAE flange ports	Bottom	0	•	•	•	-	•	•	•	•	•	•	•	•	<b>L0</b>
		Rear	0	•	•	•	-	•	•	•	•	•	•	•	•	<b>M0</b>
		Side	0	•	•	•	-	•	•	•	•	•	•	•	•	•
	1		•	•	•	-	•	•	•	•	•	•	•	•	•	<b>N1</b>
	Threaded	Side	0	•	•	•	-	•	•	•	•	-	-	-	-	<b>Q0</b>
			1	•	•	•	-	•	•	•	•	•	-	-	-	<b>Q1</b>
Rear		0	•	•	•	-	•	•	•	•	•	-	-	-	<b>P0</b>	
			0 = Without suitability for valves 1 = Compatible with flushing valve													
Drain ports T1 and T2																
<b>06</b>		1	1	1	1	1	1	1	1	1	1	1	1	1	1	<b>M1</b>
Suitable for use of speed sensor																
<b>07</b>	Yes	•	•	•	•	•	•	•	•	•	•	•	•	•	•	<b>1</b>
	No	•	•	•	•	•	•	•	•	•	•	•	•	•	•	<b>0</b>
Speed sensor																
<b>08</b>	1 frequency signal		•	•	•	•	•	•	•	•	•	•	•	•	•	<b>1</b>
	1 signal with connector		•	•	•	•	•	•	•	•	•	•	•	•	•	<b>1P</b>
	2 signals with connector		•	•	•	•	•	•	•	•	•	•	•	•	•	<b>2P</b>
	No		•	•	•	•	•	•	•	•	•	•	•	•	•	<b>0</b>
Flushing valve																
<b>09</b>	Without		•	•	•	•	•	•	•	•	•	•	•	•	•	<b>SV</b>
	Flow rate	4,25 l/min*	•	•	•	•	•	•	•	•	•	•	•	•	•	<b>VB04</b>
		10 l/min*	•	•	•	•	•	•	•	•	•	•	•	•	•	<b>VB10</b>
		14 l/min*	•	•	•	•	•	•	•	•	•	•	•	•	•	<b>VB14</b>
Low temperature option																
<b>10</b>	Yes (NBR)		•	•	•	•	•	•	•	•	•	•	•	•	•	<b>N</b>
	No (FKM)		•	•	•	•	•	•	•	•	•	•	•	•	•	<b>F</b>

Légende:  
 • Existing model  
 – Not yet existing

\*(Δp = 25 bar)





► Inlet ports

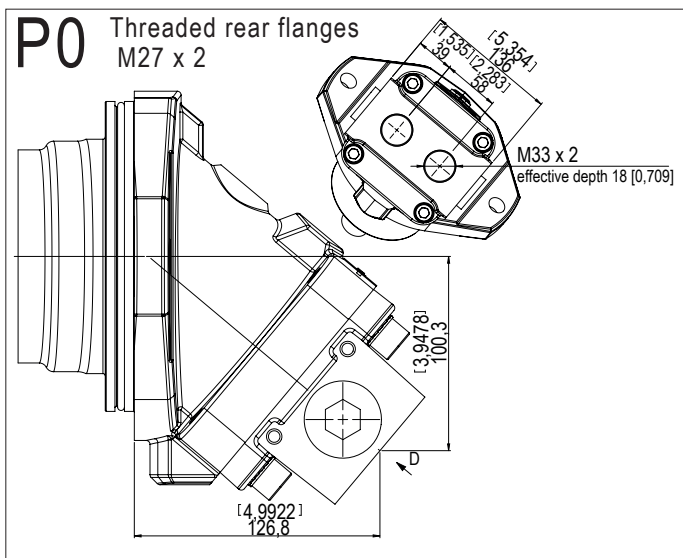
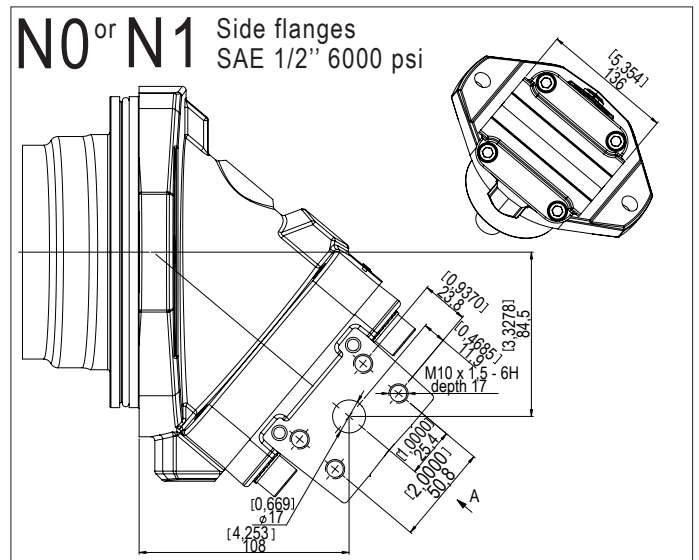
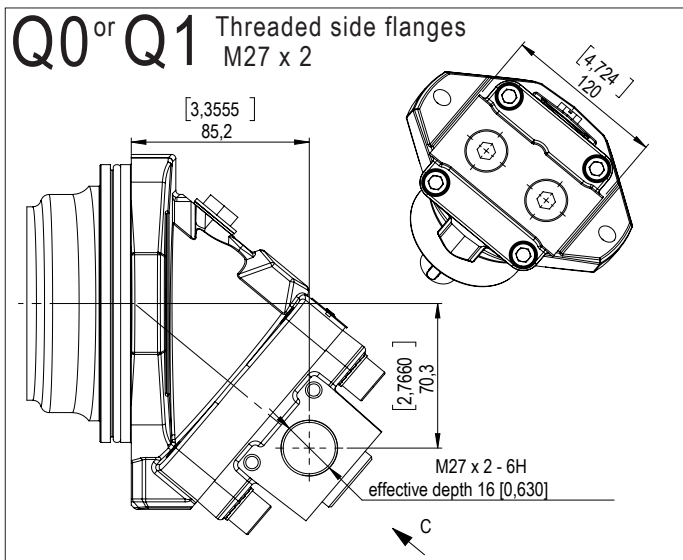
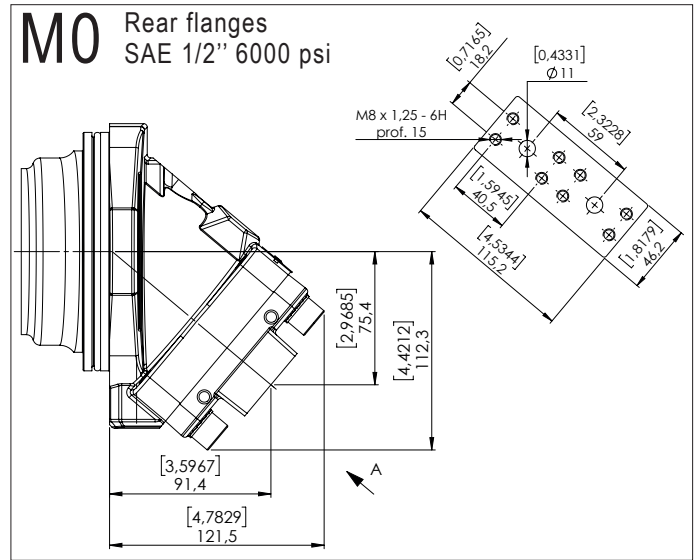
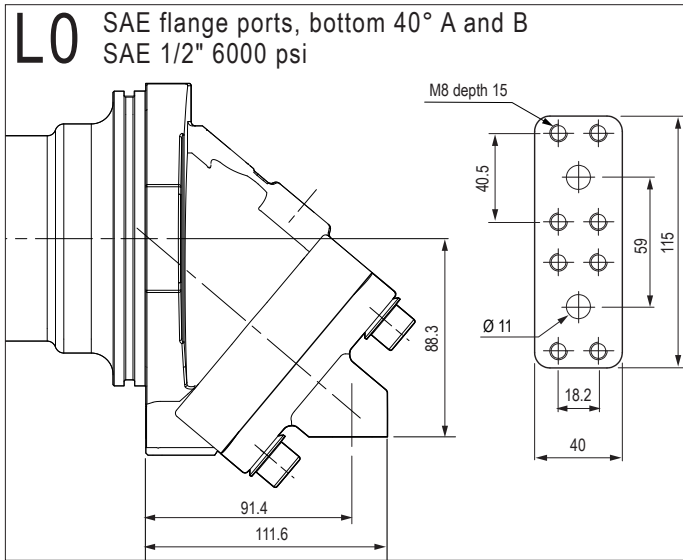

Dimensions are given only as an indication. Measurements in mm and [inches].

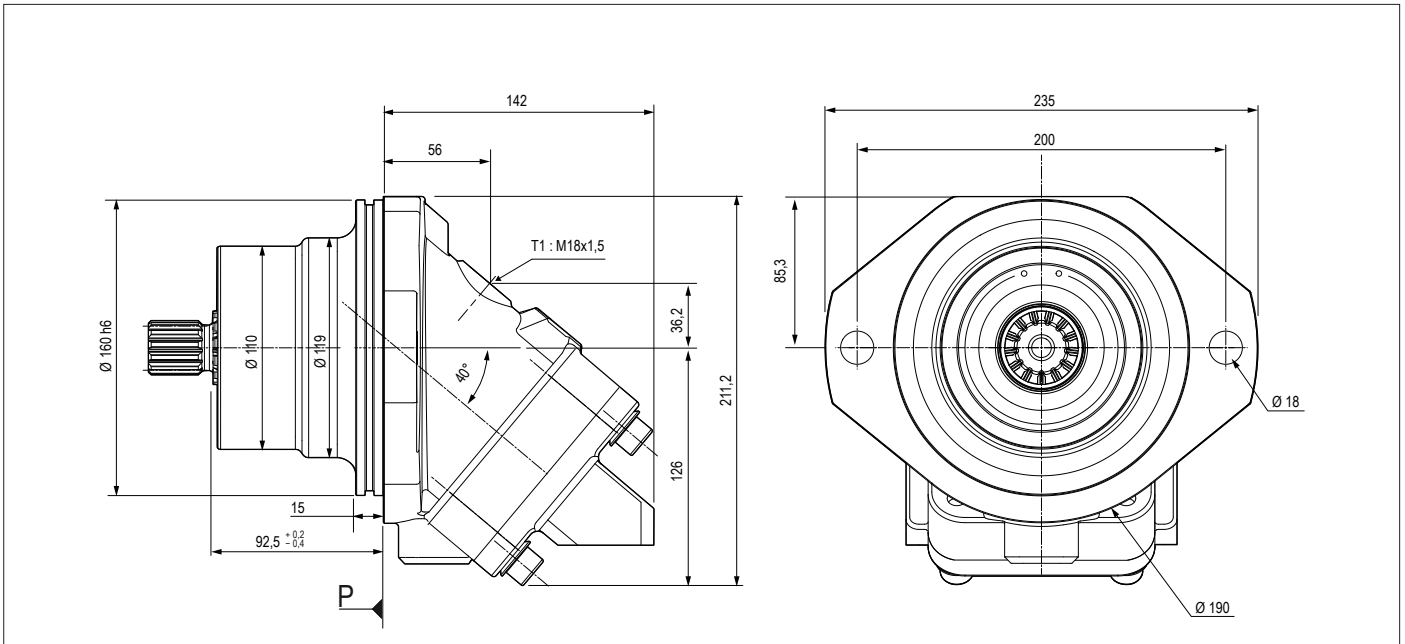

### ► Shaft end

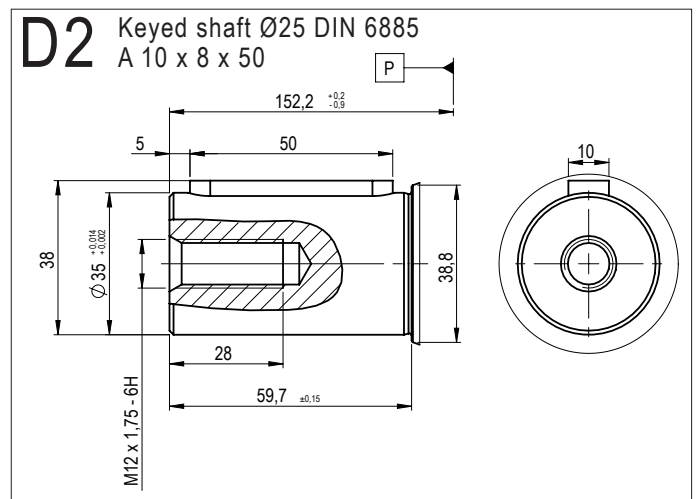
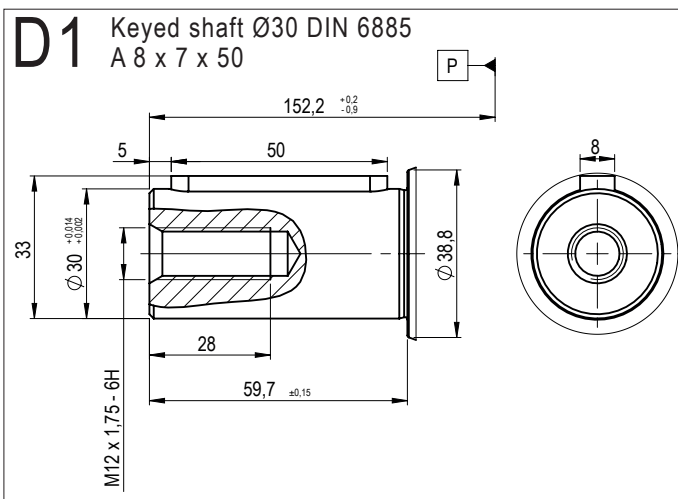
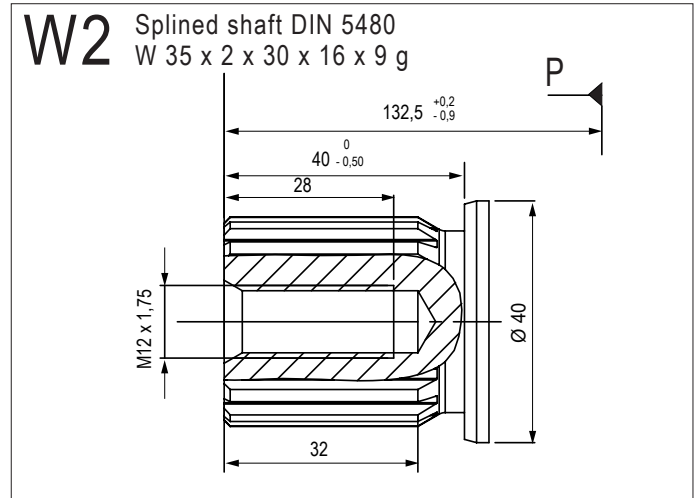
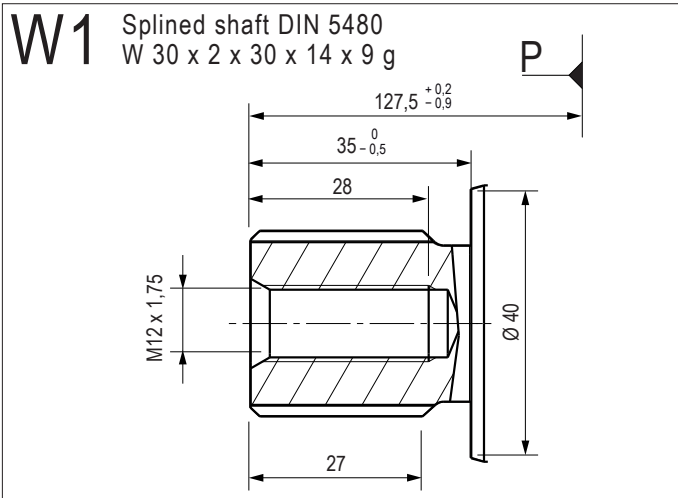

► Inlet ports

**L0** Bottom flanges  
SAE 3/4" 6000 psi

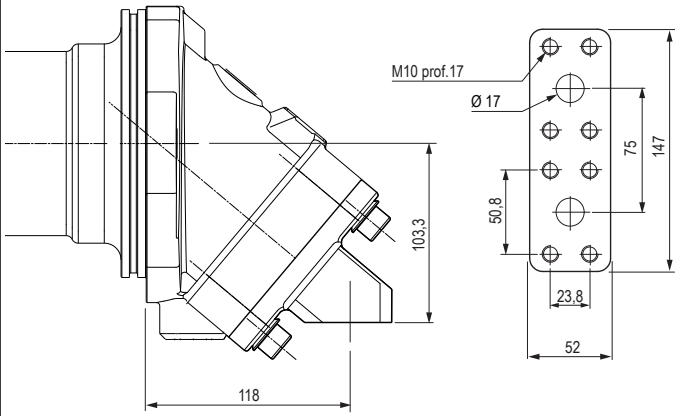

**M0** Rear flanges  
SAE 3/4" 6000 psi

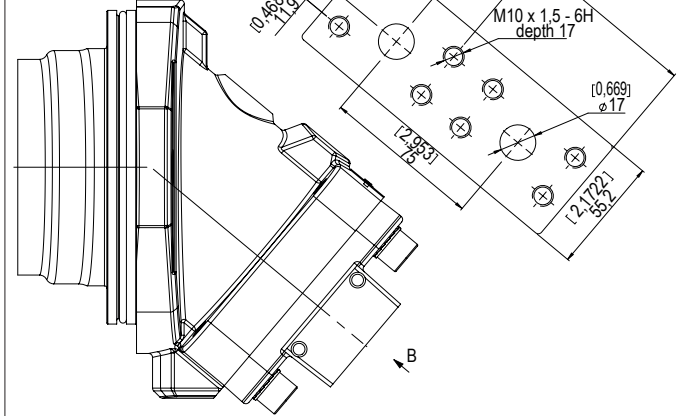

**Q0 or Q1** Threaded side flanges  
M33 x 2

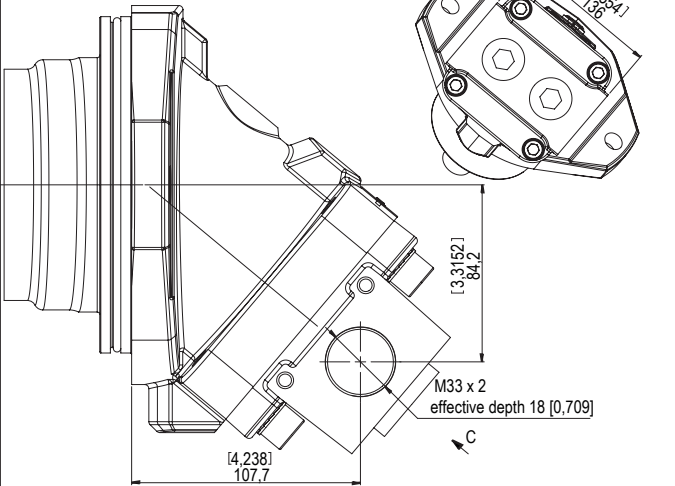

**N0 or N1** Side flanges  
SAE 3/4" 6000 psi

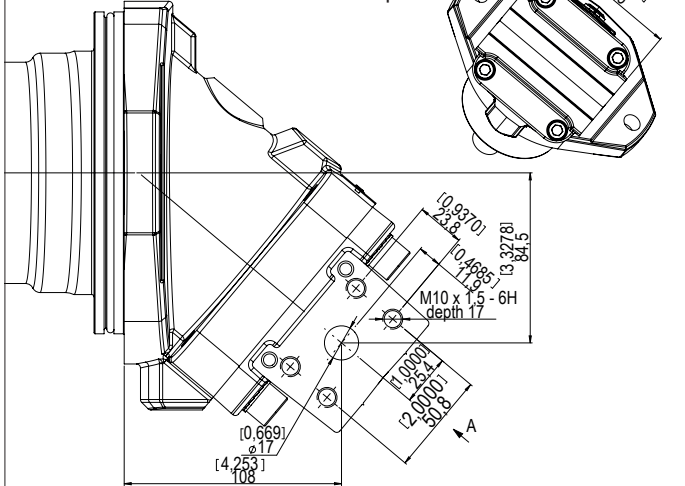

**P0** Threaded rear flanges  
M33 x 2

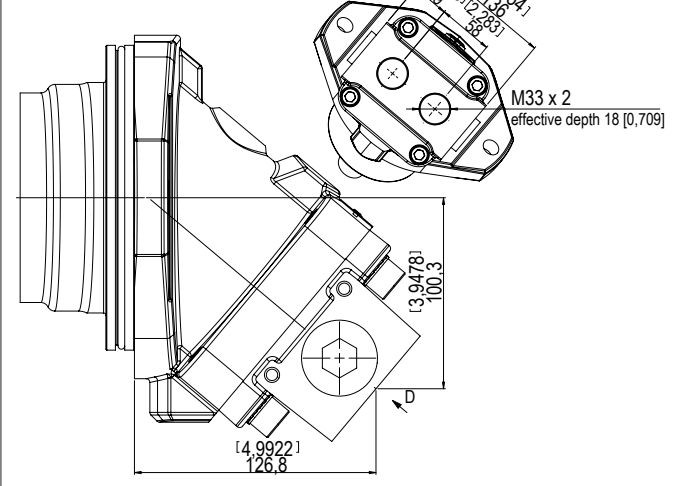

Dimensions are given only as an indication. Measurements in mm and [inches].



► Inlet ports

**L0** SAE flange ports, bottom 40° A and B  
SAE 1" 6000 psi

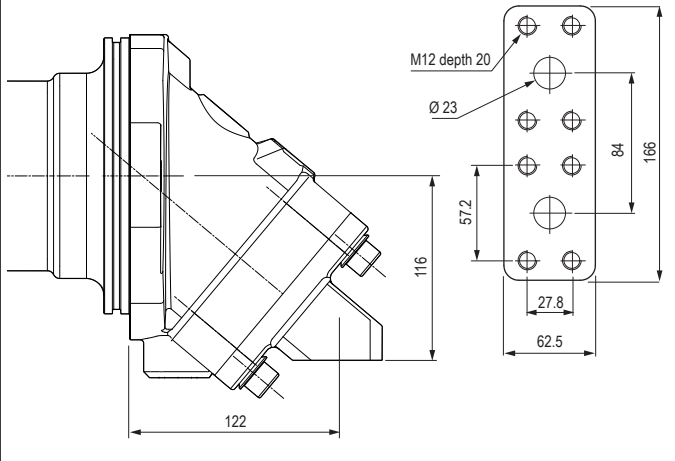

**M0** Rear flanges  
SAE 1" 6000 psi

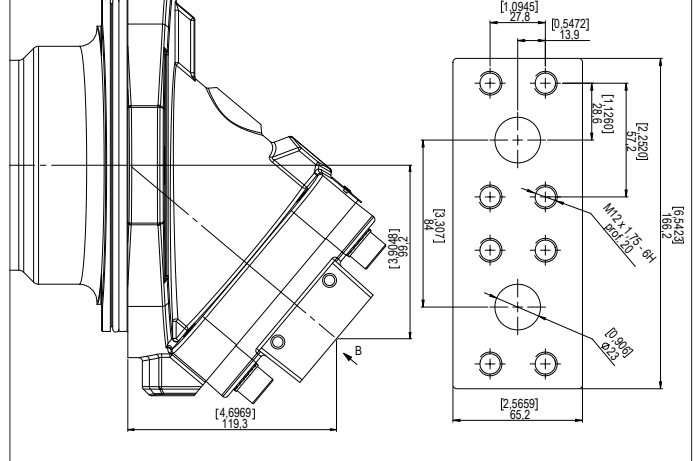

**Q0 or Q1** Threaded side flanges

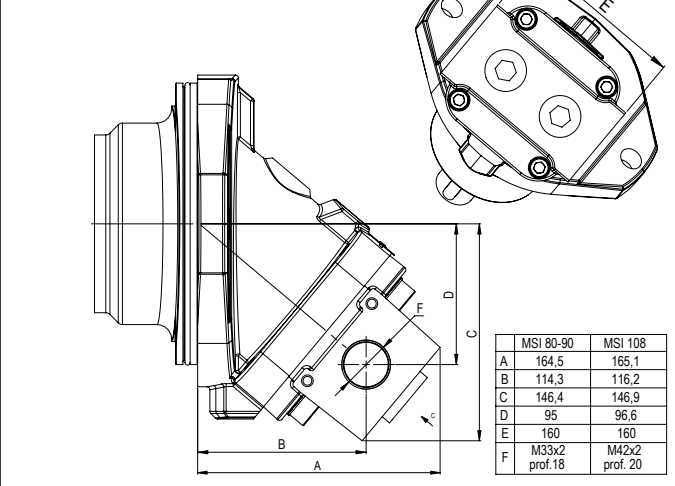

**N0 or N1** Side flanges  
SAE 1" 6000 psi

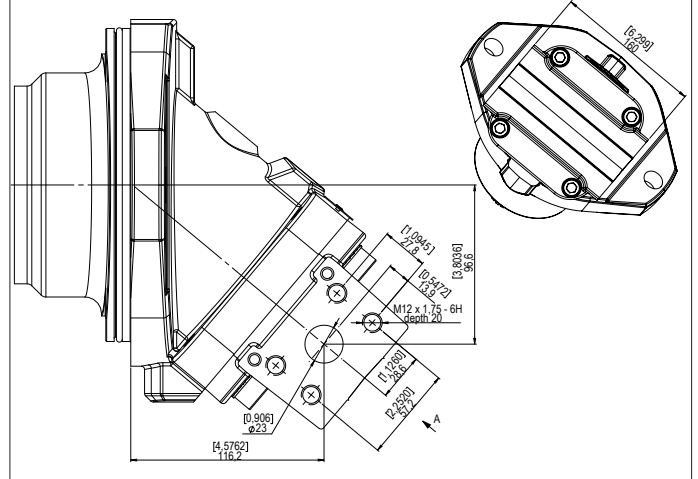

**P0** Threaded rear flanges

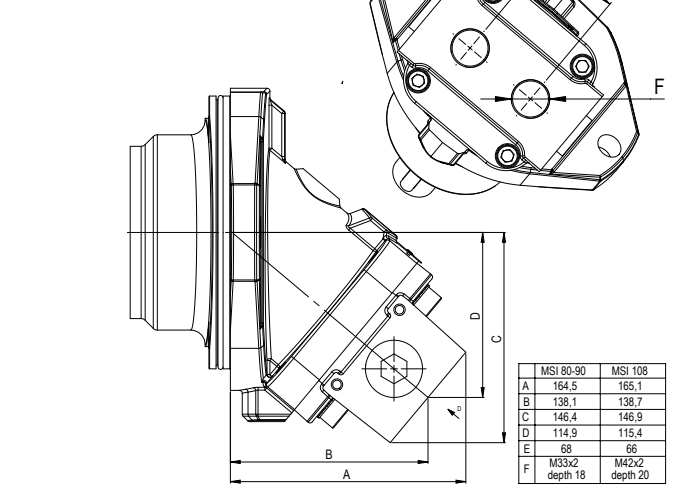

Dimensions are given only as an indication. Measurements in mm and [inches].

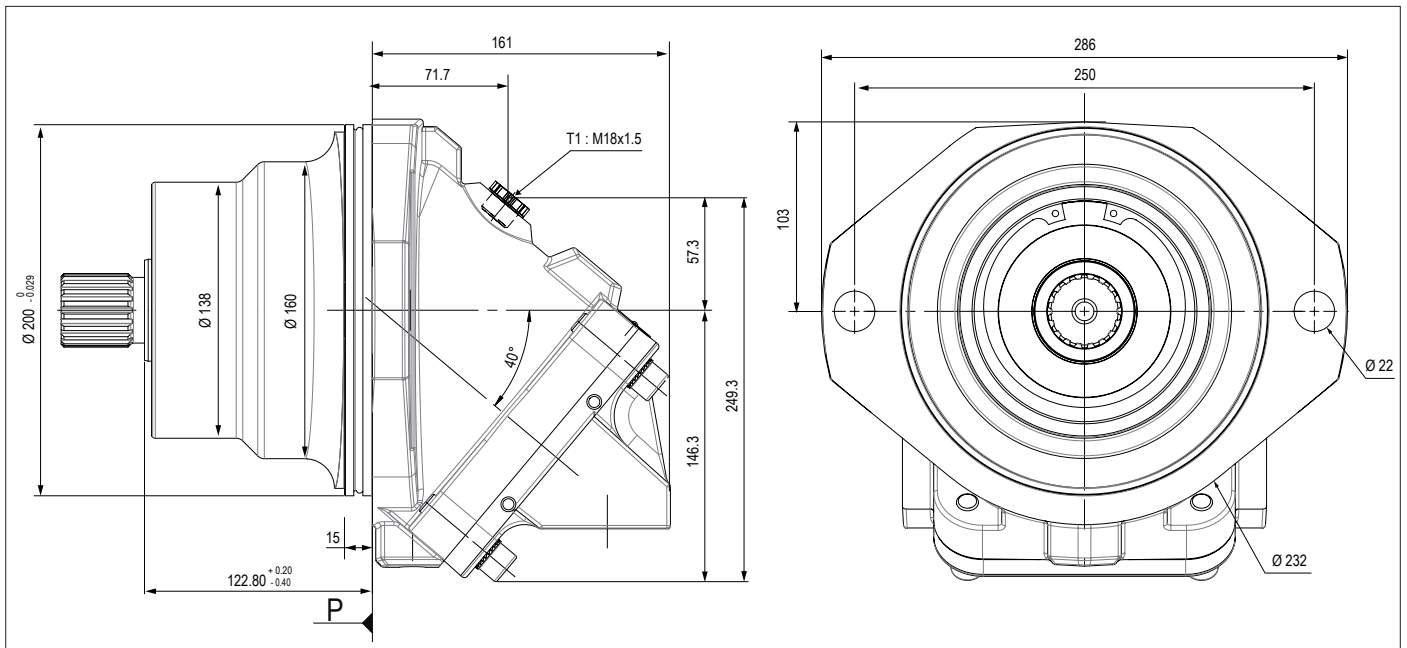

### ► Shaft end

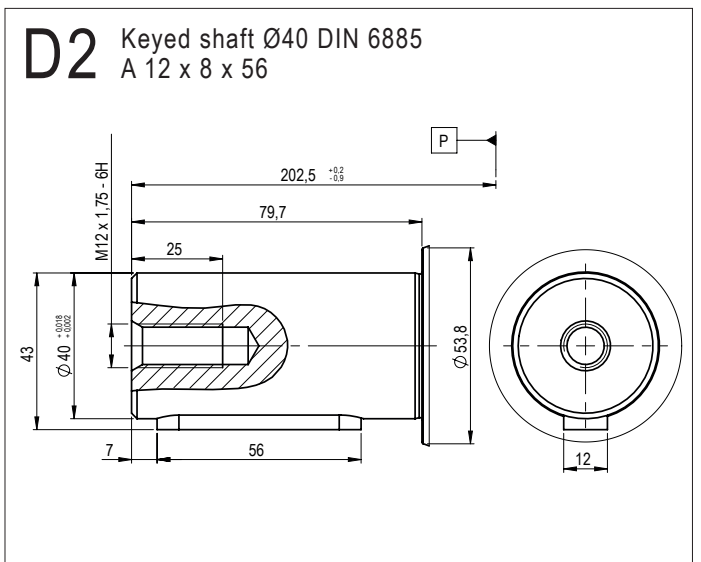
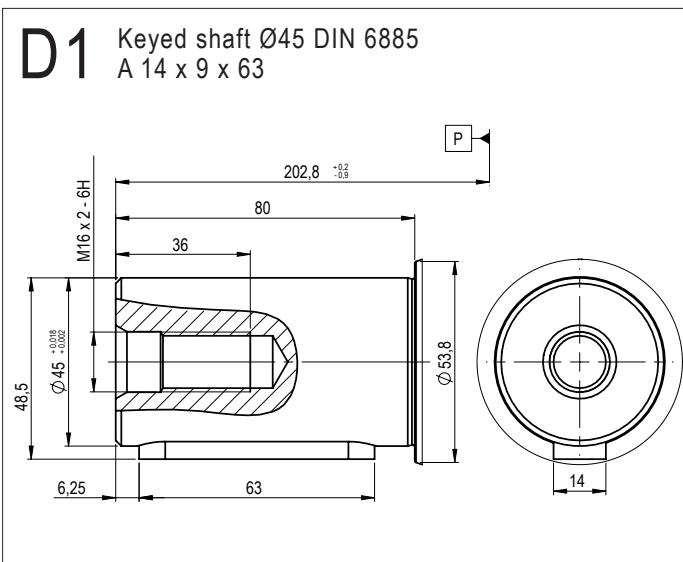
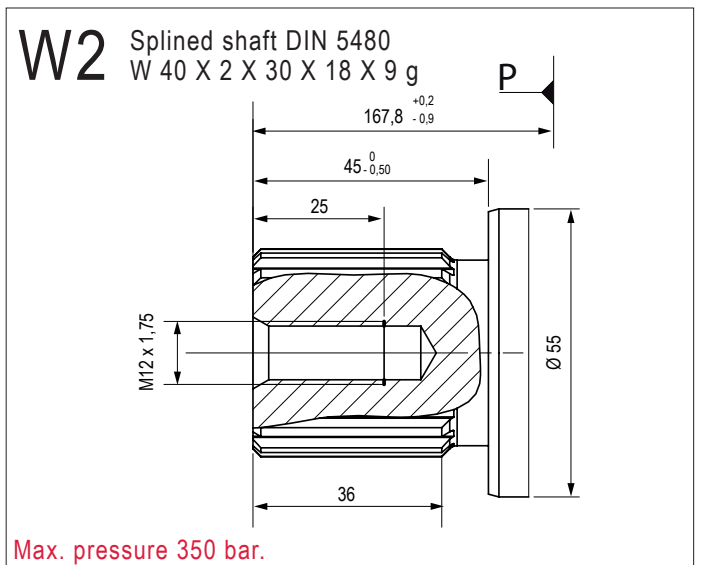
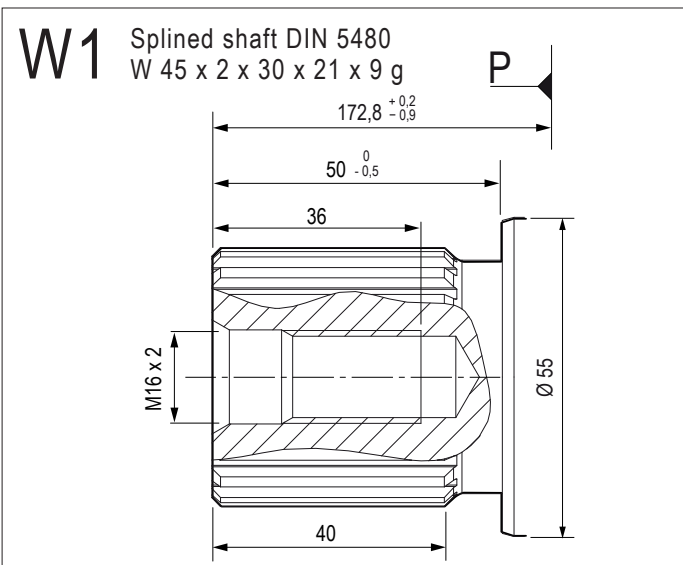

Dimensions are given only as an indication. Measurements in mm and [inches].



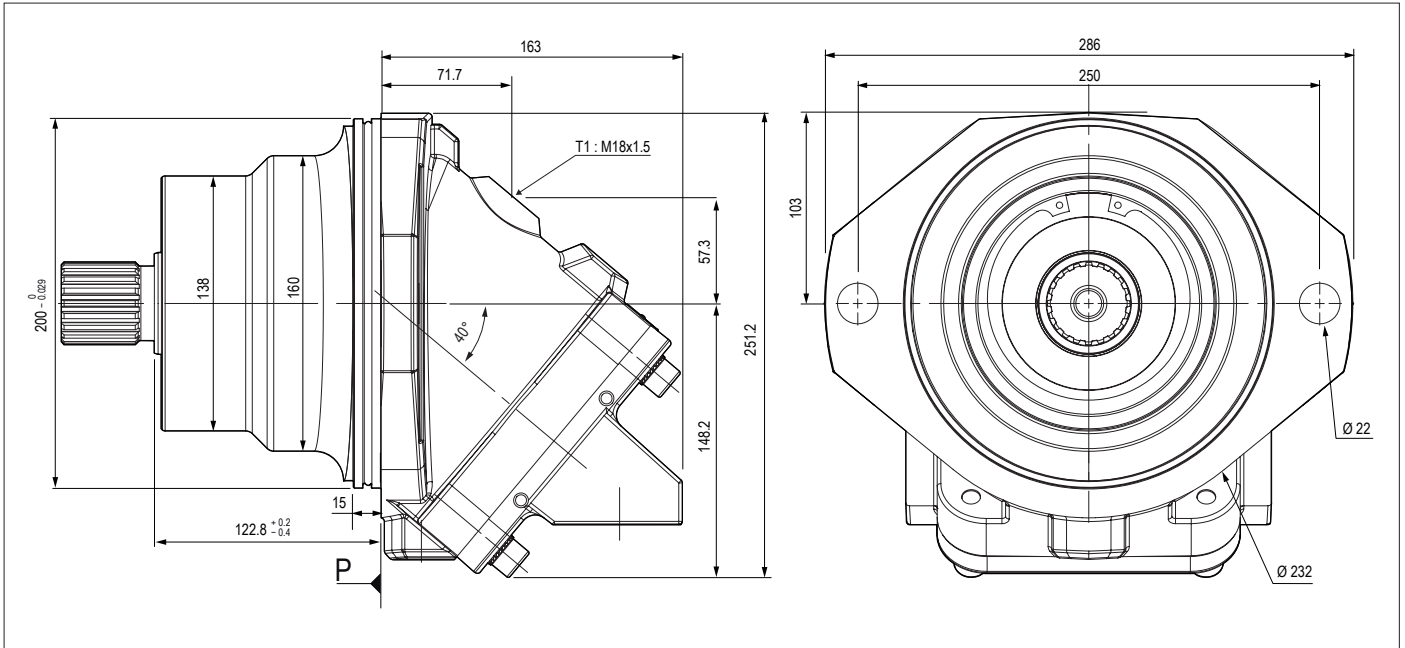

### ► Shaft end

**W1** Splined shaft DIN 5480  
W 45 x 2 x 30 x 21 x 9 g

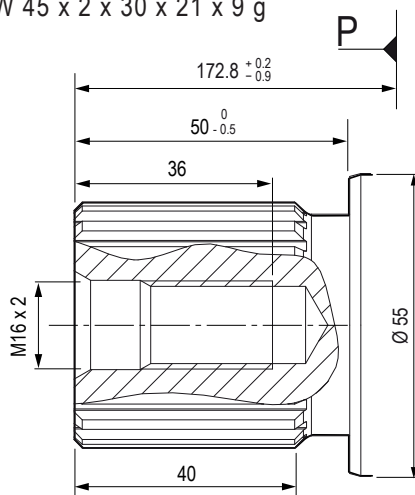

**W2** Splined shaft DIN 5480  
W 40 X 2 X 30 X 18 X 9 g

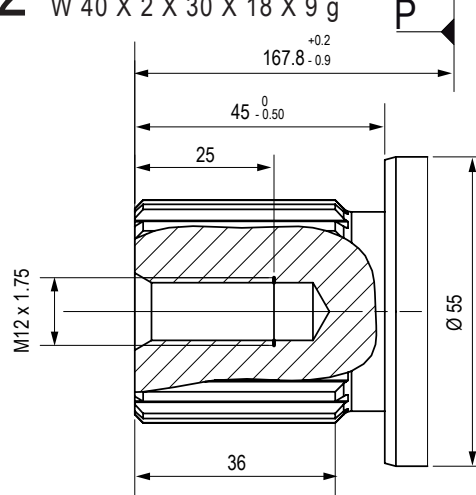

**D1** Keyed shaft  $\varnothing 45$  DIN 6885  
A 14 x 9 x 63

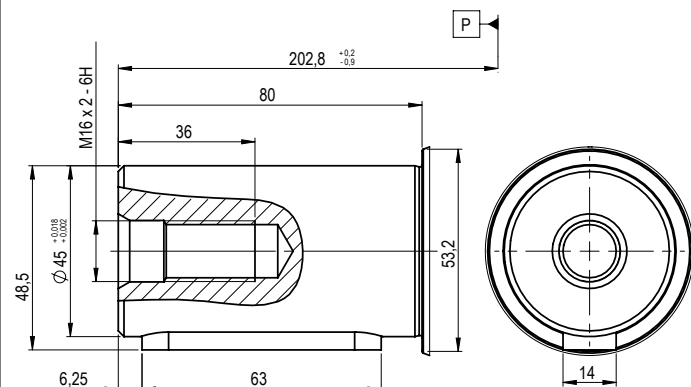









## SPEED SENSOR & INDICATOR OF DIRECTION OF ROTATION

**M, MA, MSI series motors** can be fitted with an induction type speed sensor, to measure rotating speed and also direction of rotation. This accessory may only be used on motors which are suitably adapted to take it (see the order code system).

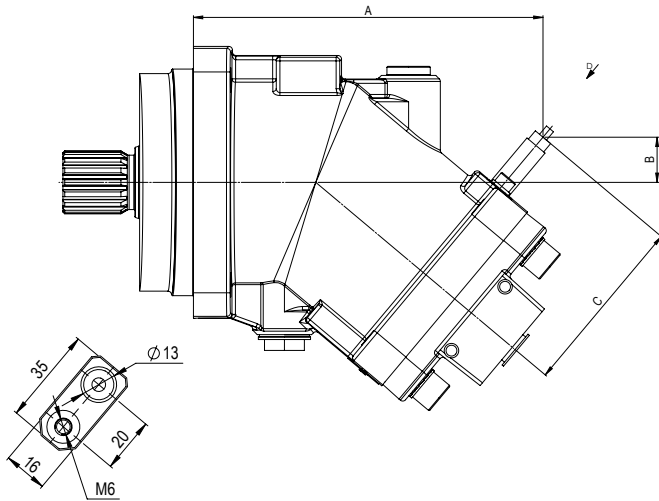

### ► Technical data for the sensor

Supply voltage	8...32 V DC
Current consumption	maximum 15 mA @ 24 Vdc
Output frequency	0 Hz...20 kHz
Protection type	IP 6K9K
Operating temperature	- 104°F...+ 257°F (- 40°C...+ 125°C)
Cable length	1500 mm

Series	Motor models	A (mm)	B (mm)	C (mm)	Number of teeth *
M	M 5	133	61	86	26
	M 12 - 18	152	33	88	30
	M 25	169	32	91	33
	M 28 - 32 - 35 - 41	174	28	91	33
	M 41R - 45 - 50 - 63	192	24	98	39
	M 80 - 90 - 108	218	18	103	44
	M 108R - 125	225	46	121	64
	M 160 - 180	250	47	126	68
MA	MA 10 - 12 - 16 - 18	162	32	87	30
	MA 25	173	41	92	35
	MA 32 - 41	173	41	92	35
	MA 45 - 50 - 63	193	35	96	39
	MA 80 - 90 - 108	223	30	101	44
	MA 108R - 125	251	45	122	64
	MA 160 - 180	282	47	126	68
	MA 250	125	115	-	74
MSI	MSI 28 - 32 - 41	97	43	91	35
	MSI 45 - 50 - 63	117	36	96	39
	MSI 80 - 90 - 108	125	31	101	44
	MSI 108 R - MSI 125	142	45	122	64
	MSI 160 - MSI 180	169	50	130	68

\* The motors suitable for use with a speed sensor are fitted with a gear wheel on the barrel.

When this barrel rotates, it produces a signal proportional to rotating speed, and which is picked up by the sensor.

## FLUSHING VALVE

Used to create engine cooling flow, this valve is essential for heavy-duty applications and promotes the longevity of engines in high-stress applications.

The valve draws a portion of the hydraulic fluid from the return port (low pressure) and reintroduces it into the motor casing. This supply is then discharged through the motor's drain.

As standard, we offer three flushing flow rates (calculated for a  $\Delta p$  of 25 bar):

- VB04: 4.25 l/min
- VB10: 10 l/min
- VB14: 14 l/min

The flushing valve is only available for motors with side ports (N1 or Q1).

### ► Dimensions

Series	Type of motor	X (mm)	Y (mm)
M	M 25	207	116
	M 28 - 32 - 35 - 41	213	121
	M 45 - 50 - 63	235	137
	M 80 - 90 - 108	265	153
	M 108R	273	153
	M 125	275	155
	M 160 - 180	313	172
MA	MA 25	221	116
	MA 32 - 41	228	122
	MA 45 - 50 - 63	256	137
	MA 80 - 90	286	153
	MA 108 R	305	157
	MA 125	307	159
	MA 160 - 180	345	170
MSI	MSI 28 - 32 - 41	150	121
	MSI 45 - 50 - 63	175	137
	MSI 80 - 90 - 108	187	153
	MSI 108R - 125	197	158

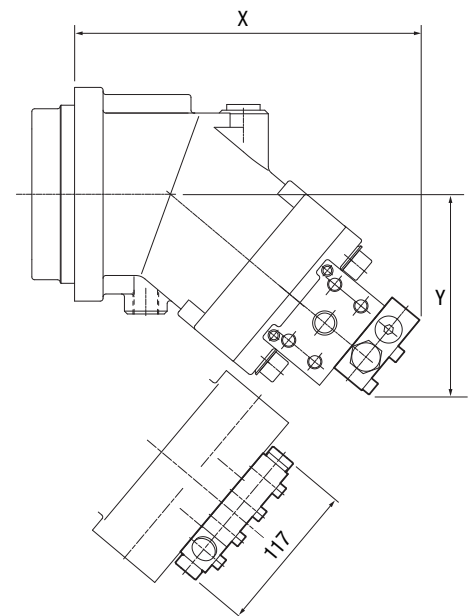

### ► Schematic Diagram of the Flushing valve

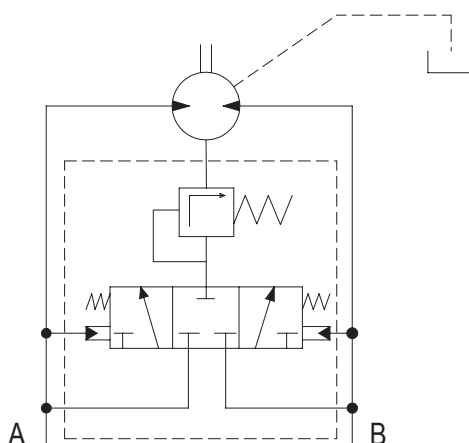

### Examples of other valves available upon request (please inquire):

#### Anti-cavitation valve

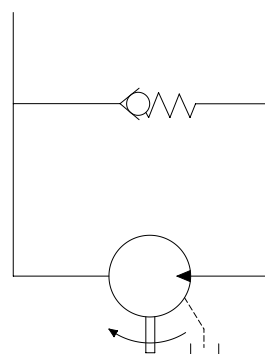

#### Double Limiting Valve

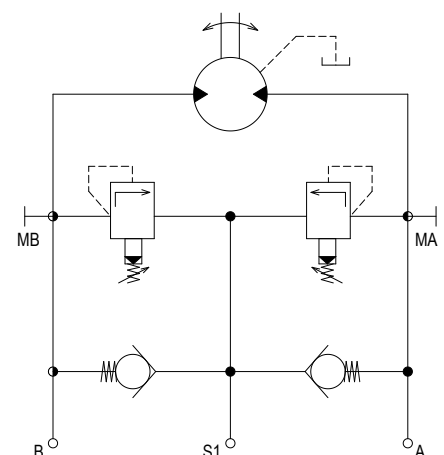

# Drainless motor

## bent axis hydraulic motor

HYDRO LEDUC is now able to offer drainless motors for either **single direction of rotation** or **bi-directional use**, under certain conditions and on request (giving details of your application).

### ADVANTAGES

#### No drainline needed

- ▶ Only two hose lines are required: supply line and output.
  - ▶ The motor is drained through the return line.
- It is fitted with a high pressure lip seal.

### CHARACTERISTICS

- Working speed:  
Please consult our Technical Department with details of your applications.
- Max. pressure on the return line: 25 bar.

#### ▶ Schematic drawing for use in single direction of rotation

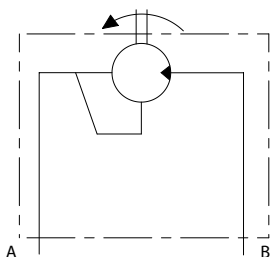

#### ▶ Schematic drawing for bi-directional use

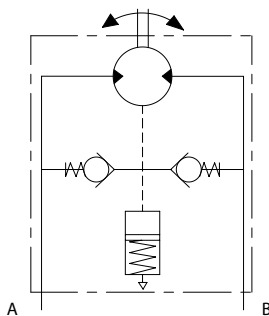

For **bi-directional** applications, the motor is fitted with an accumulator integrated in the back piece, to compensate possible pressure peaks in the housing (for example from rapid change in direction).

Please contact our Customer Service Department with details of your application.

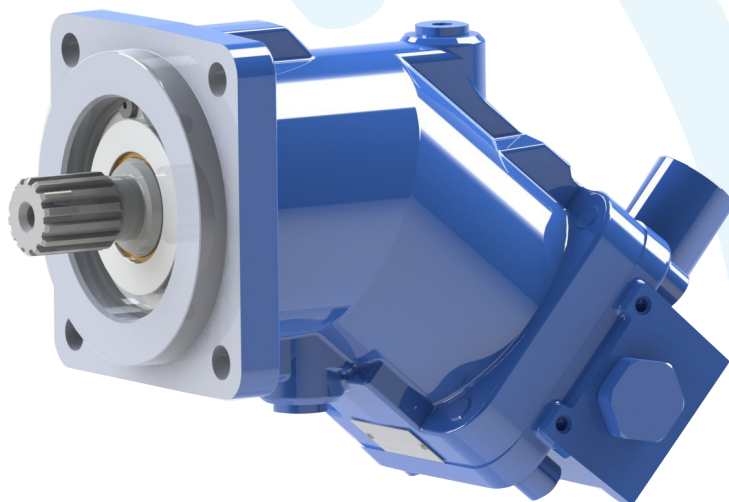
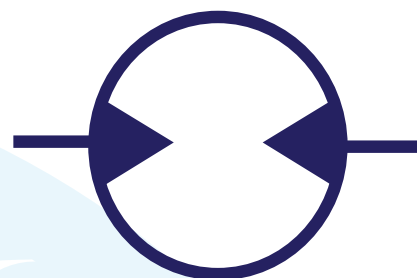



## PISTON PUMPS FOR TRUCKS

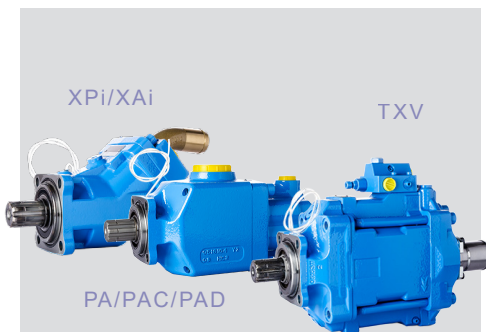

HYDRO LEDUC offers 3 ranges of piston pumps perfectly suited for truck applications, mountable on power take-off.

- Fixed displacement from 12 to 130 cm<sup>3</sup>/rev
- Fixed displacement, dual flow, from 2x25 to 2x75 cm<sup>3</sup>/rev
- Variable displacement, with LS (load sensing) control, from 40 to 150 cm<sup>3</sup>/rev.

## PUMPS FOR MOBILE & INDUSTRIAL APPLICATIONS



The W series consists of fixed displacement pumps, and the TXVA series consists of variable displacement pumps. These pumps are capable of operating at high pressures while occupying minimal space.

### ► W Series (ISO) and WA Series (SAE)\*

- Fixed displacements from 5 to 180 cm<sup>3</sup>/rev
- Flanges according to ISO 3019/2 or SAE standards
- Shafts according to DIN or SAE standards

### ► TXVA Series

- Variable displacements up to 92 cm<sup>3</sup>/rev
- SAE shafts and flanges

\* For the SAE version, please contact our Customer Service.

## HYDRAULIC MOTORS

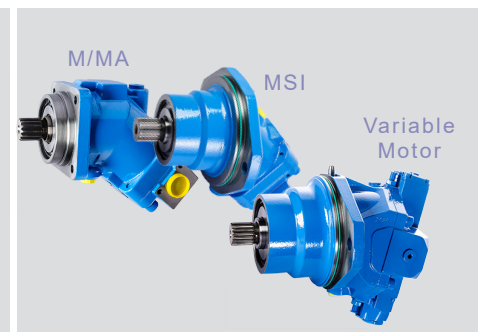

Axial Piston Motors with Constant and Variable Displacement

- Models from 5 to 180 cc/rev
- DIN and SAE Versions
- Constant Displacement, Motors without Leak Oil Connection Special Version.

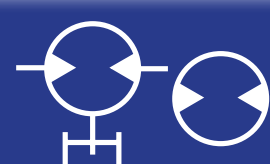



Complete catalog: [www.hydroleduc.com](http://www.hydroleduc.com)

## HYDROPNEUMATIC ACCUMULATORS



Diaphragm, Bladder, Bladder-Diaphragm, and Piston Accumulators in spherical and cylindrical designs.

- Storage capacities from 0.02 to 50 liters
- Operating pressures up to 400 bar
- Accessories for operating hydraulic pressure accumulators.

## MICROHYDRAULIC



A specific field of application for Hydro Leduc's expertise.

- Axial and radial piston pumps with constant and variable displacement.
- Axial piston micro-hydraulic motors.
- Micro-hydraulic components (electric drives, valves, control devices, etc).
- HYDRO LEDUC offers a comprehensive range of reliable solutions for extreme applications and compact spaces.

Our development team takes care of your individual requirements.

In close collaboration with the decision-makers in your organization, we work together with you to develop solutions according to your specifications.



A passion for hydraulics

**HYDRO LEDUC SAS**

Head Office & Factory  
BP 9 F-54122 AZERAILLES  
FRANCE  
Tel. +33 (0)3 83 76 77 40

**HYDRO LEDUC GmbH**

Am Ziegelplatz 20  
D-77746 SCHUTTERWALD  
DEUTSCHLAND  
Tel. +49 (0) 781-9482590  
Fax + 49 (0) 781-9482592

**HYDRO LEDUC AB**

Betongvägen 11  
461 38 TROLLHÄTTAN  
SWEDEN  
Tel. + 46 (0) 520 10 820

**HYDRO LEDUC BV**

Ericssonstraat 2  
5121 ML RIJEN  
THE NETHERLANDS  
Tel. +31 161 747816

**HYDRO LEDUC N.A. Inc.**

Grand Parkway Industrial Park  
23549 Clay Road  
KATY, TX 77493  
USA  
Tel. +1 281 679 9654

*make it simple*

[www.hydroleduc.com](http://www.hydroleduc.com)



HYDRO LEDUC  
SAS with capital of 4 065 000 €  
EORI FR31902742100019  
RC Nancy B 319 027 421  
[contact@hydroleduc.com](mailto:contact@hydroleduc.com)

EN\_FIX MOTORS\_20240828