

CHARACTERISTICS OF THE M SERIES MOTORS

Motor model	Displacement (cc/rev)	Continuous max. speed (1) (rpm)	Intermittent max. speed (1) (rpm)	Max. flow absorbed (l/mn)	Torque (N.m/bar)	Torque at 350 bar (N.m)	Theoretical maximal power at 400 bar (kW)	Max. allowable pressure continuous / peak (bar)	Weight (kg)
M 5	5	8000	8800	40	0.08	28	26.6	400 / 450	4.4
M 12	12	8000	8800	96	0.19	67	64	400 / 450	5.5
M 18	18.0	8000	8800	144	0.29	100	96	400 / 450	5.5
M 25	24.9	6300	6900	157	0.40	139	104.5	400 / 450	11.5
M 28	27.7	6300	6900	175	0.44	154	116.3	400 / 450	11.5
M 32	32.1	6300	6900	202	0.51	179	134.8	400 / 450	11.5
M 41	41.1	5600	6200	230	0.65	229	153.4	400 / 450	11.5
M 41 R (2)	41.1	5000	5500	206	0.65	229	137	400 / 450	18
M 45	45.4	5000	5500	227	0.72	253	151.3	400 / 450	18
M 50	50.3	5000	5500	252	0.80	280	167.6	400 / 450	18
M 63	63	5000	5500	315	1.00	351	210	400 / 450	18
M 80	80.4	4500	5000	362	1.28	448	241.2	400 / 450	23
M 90	90	4500	5000	405	1.43	501	270	400 / 450	23
M 108	108.3	4000	4400	433	1.72	603	288.8	400 / 450	23
M 108 R (3)	108.3	3400	4500	368	1.72	603	245.4	400 / 450	35
M 125	125.4	3400	4500	426	2.00	699	284.2	400 / 450	35
M 160	160	3600	4000	576	2.55	891	384	400 / 450	48.5
M 180	180.6	3600	4000	650	2.87	1006	433.4	400 / 450	48.5

(1) For higher speeds, please contact us.

(2) The M 41 R motor is in the frame size of the M 45.

(3) The M 108 R motor is in the frame size of the M 125.

► Acceptable forces applied to motor shaft

Motor model	5	12	18	25	28	32	41	41 R	45	50	63	80	90	108	108 R	125	160	180	
Fr	N	710	2800	4000	6000	6200	6500	7000	7000	6500	7500	9000	10500	11000	11500	12500	14500	18000	20000
Fa	N/bar *	10	15	20	27	28	30	40	40	40	40	50	60	67	80	80	86	85	95

Fr: radial force measured at mid point of length of shaft.

Fa: axial force which tends to push the shaft inwards.

* Differential pressure between A and B.

For other forces, please contact us.

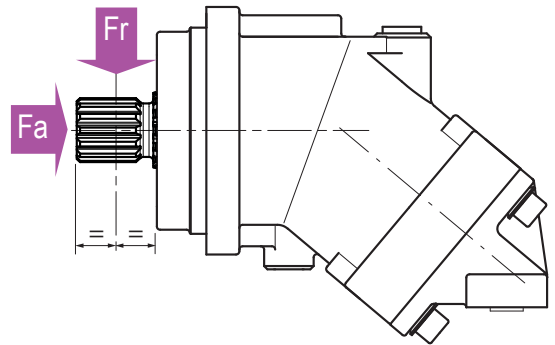
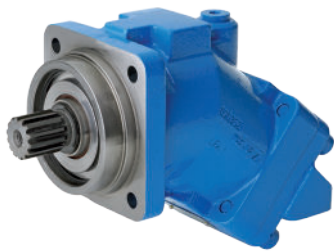

To obtain the code for your motor, complete the different parameters 02, 04, 05, 06, 07, 08, 09 and 10 in the table on the left according to the options you require (see table below).

M	...	A	SP															
01	02	03	04	05	06	07	08	09	10	11															
Motor																									
01	Motor										M														
Displacement																									
02				5	12	18	25	28	32	41	41R	45	50	63	80	90	108	108R	125	160	180				
Mounting flange																									
03				CETOP 2bolts	4 bolts ISO 3019-2										A										
Shaft																									
04	DIN 5480 splined	-	W25	W25	W25	W30	W30	W30	W30	W30	W30	W30	W30	W40	W40	W40	W45	W45	W50	W50	W1				
		-	-	-	W30	W25	W25	-	-	W35	W35	W35	W35	-	-	W40	W40	-	-	W2					
	DIN 6885 keyed	Ø 18	Ø 25	Ø 25	Ø 25	Ø 30	Ø 30	Ø 30	-	Ø 30	Ø 30	Ø 30	Ø 40	Ø 40	Ø 40	Ø 45	Ø 45	Ø 50	Ø 50	D1					
		-	Ø 20	-	Ø 30	Ø 25	Ø 25	-	Ø 35	Ø 35	Ø 35	Ø 35	-	-	-	Ø 40	-	-	-	D2					
Inlet ports A and B																									
05	SAE flange ports	Bottom	0	-	-	-	-	•	•	•	•	•	•	•	•	•	•	•	•	•	L0				
		Rear	0	-	-	-	•	•	•	•	•	•	•	•	•	•	•	•	•	•	•	M0			
		Side	0	-	-	-	•	•	•	•	•	•	•	•	•	•	•	•	•	•	•	N0			
	Threaded	Side	0	-	•	•	•	•	•	•	•	•	•	•	•	•	-	-	-	-	Q0				
			1	-	-	-	•	•	•	•	•	•	•	•	•	•	-	-	-	-	Q1				
		Rear	0	•	•	•	•	•	•	•	•	•	•	•	•	•	-	-	-	-	P0				
<div style="border: 1px solid red; padding: 5px; display: inline-block; margin-top: 10px;"> 0 = Without suitability for valves 1 = Compatible with flushing valve </div>																									
Drain ports T1 and T2																									
06				-	•	•	•	•	•	•	•	•	•	•	•	•	•	•	•	•	M2				
				•	-	-	-	-	-	-	-	-	-	-	-	-	-	-	-	-	-	G2			
Suitable for use of speed sensor																									
07	Yes			•	•	•	•	•	•	•	•	•	•	•	•	•	•	•	•	•	•	1			
	No			•	•	•	•	•	•	•	•	•	•	•	•	•	•	•	•	•	•	•	0		
Speed sensor																									
08	1 frequency signal			•	•	•	•	•	•	•	•	•	•	•	•	•	•	•	•	•	•	1			
	1 signal with connector			•	•	•	•	•	•	•	•	•	•	•	•	•	•	•	•	•	•	•	1P		
	2 signals with connector			○	○	○	○	○	○	○	○	○	○	○	○	○	○	○	○	○	○	○	2P		
	Without			•	•	•	•	•	•	•	•	•	•	•	•	•	•	•	•	•	•	•	0		
Flushing valve																									
09	Without			•	•	•	•	•	•	•	•	•	•	•	•	•	•	•	•	•	•	SV			
	Flow rate	4,25 l/min*			-	-	-	•	•	•	•	•	•	•	•	•	•	•	•	•	•	VB04			
		10 l/min*			-	-	-	•	•	•	•	•	•	•	•	•	•	•	•	•	•	VB10			
		14 l/min*			-	-	-	•	•	•	•	•	•	•	•	•	•	•	•	•	•	•	VB14		
Low temperature option																									
10	Yes(NBR)			-	•	•	•	•	•	•	•	•	•	•	•	•	•	•	•	•	•	N			
	No (FKM)			•	•	•	•	•	•	•	•	•	•	•	•	•	•	•	•	•	•	•	F		

Legend:
 • Existing model
 ○ On request
 - Not available

*(Δp = 25 bar)

CETOP flange, 2 bolts

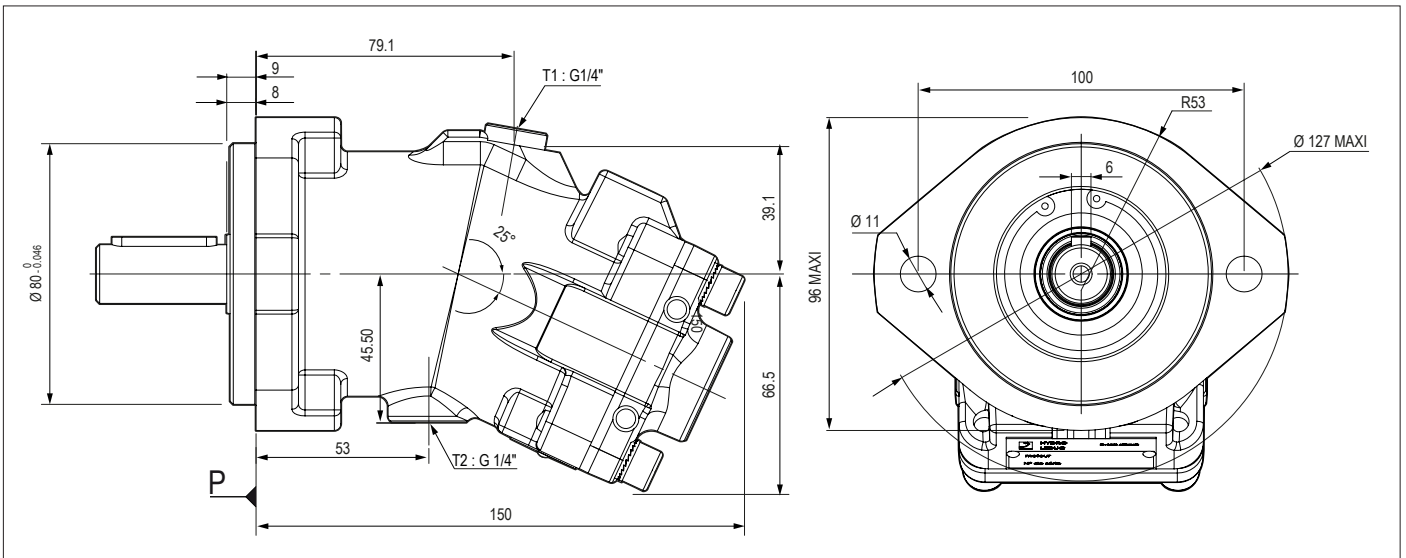

► Shaft end

D1 Cylindrical keyed shaft $\varnothing 18$
AS 6 x 6 x 32

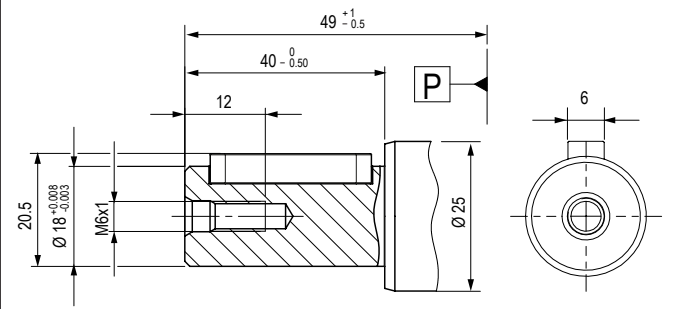

► Inlet ports

P0 Rear threaded ports A and B

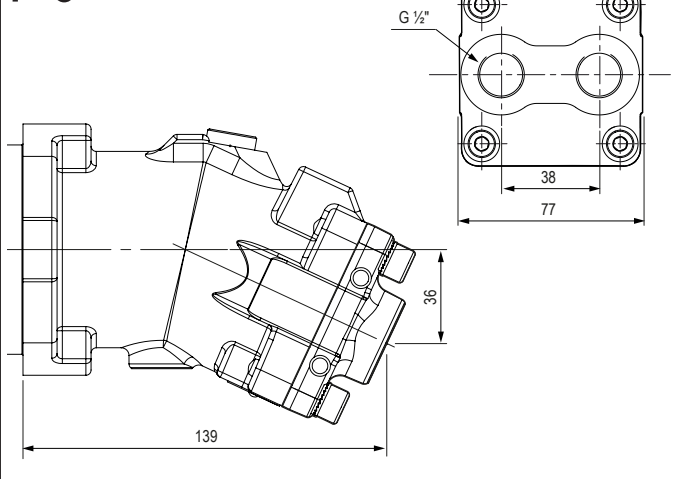

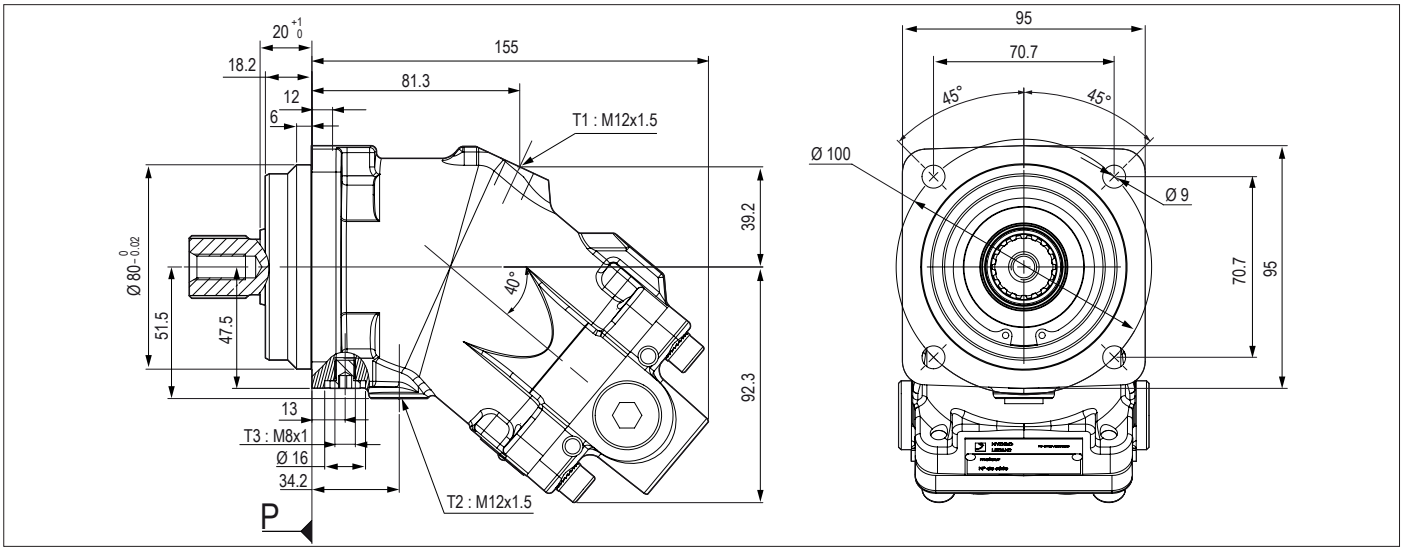

► Shaft

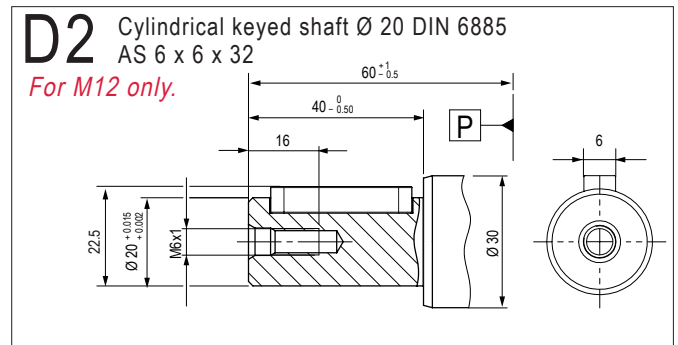
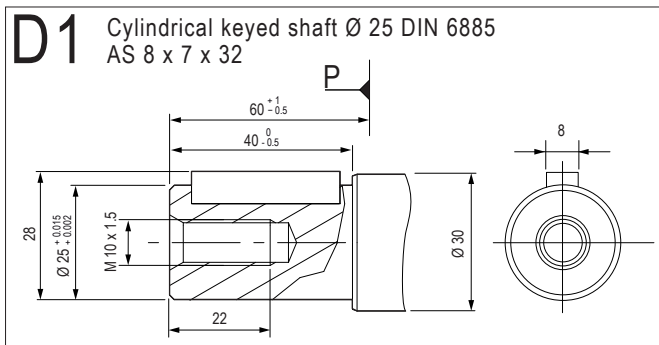
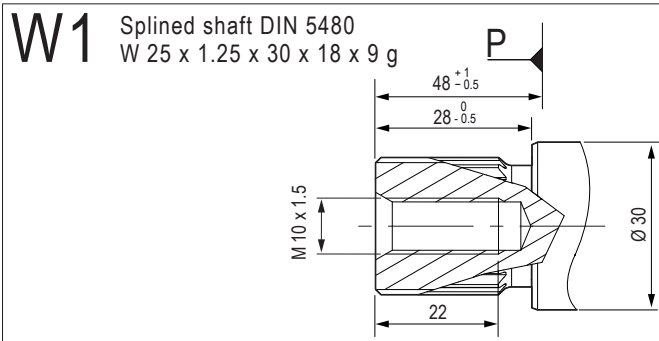

► Inlet ports

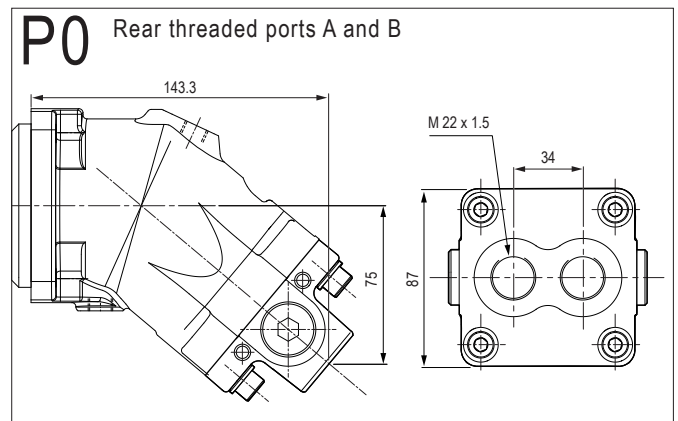
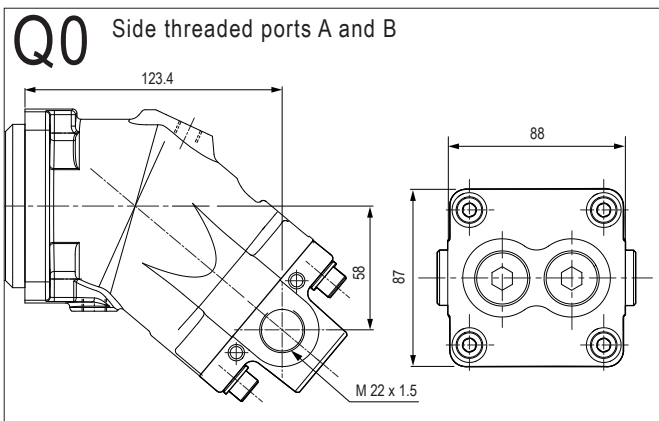

Dimensions in mm are given only as an indication.

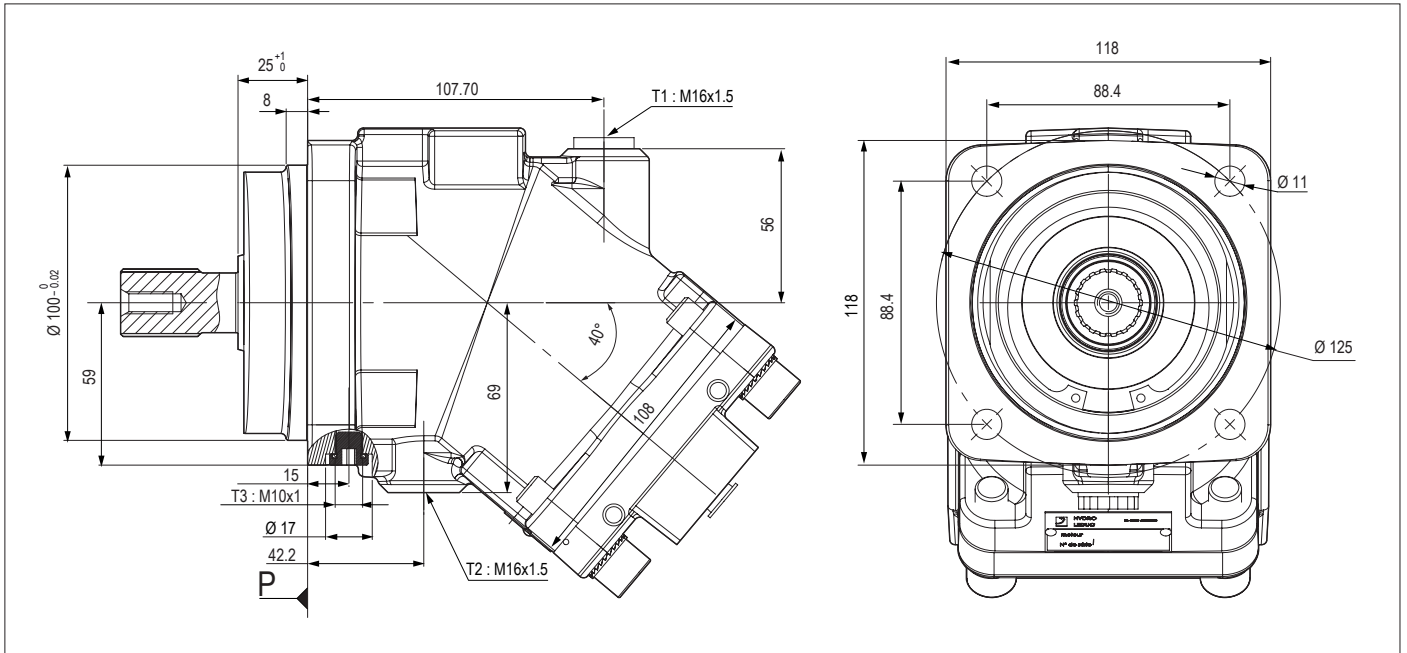

► Shaft end

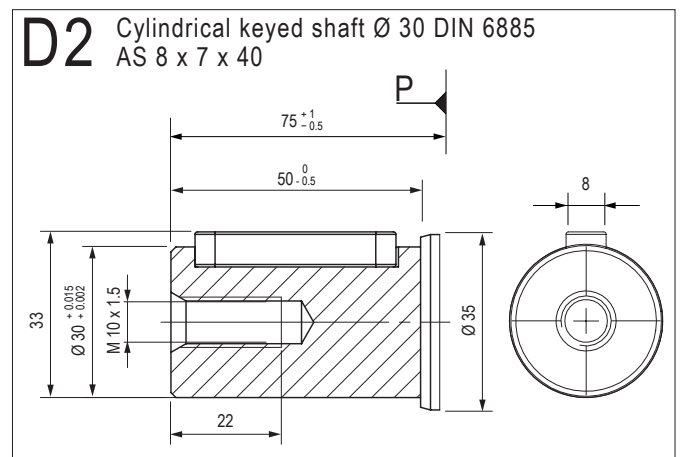
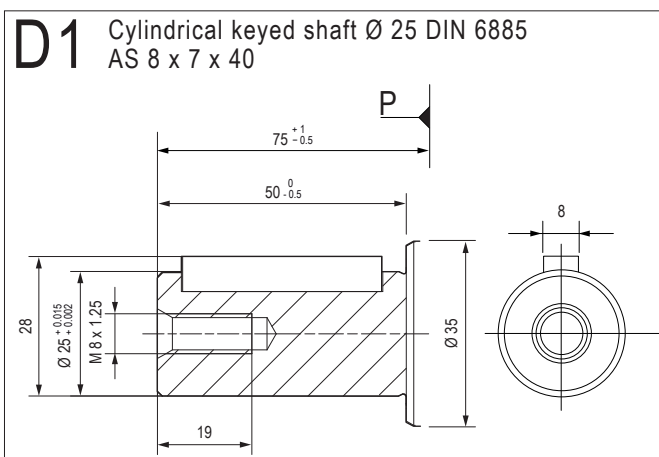
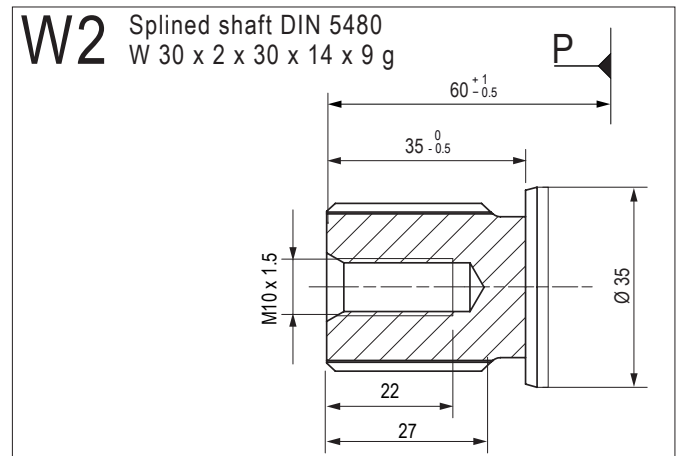
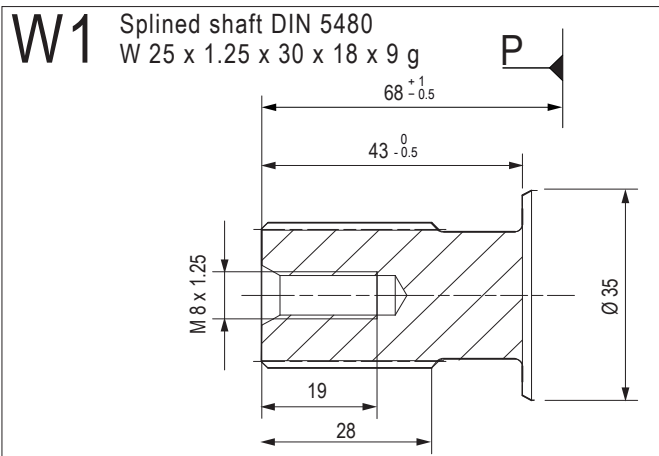

► Inlet ports

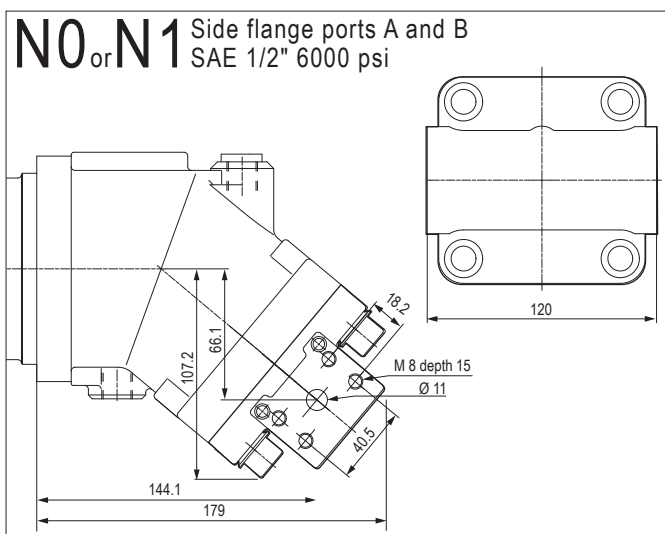
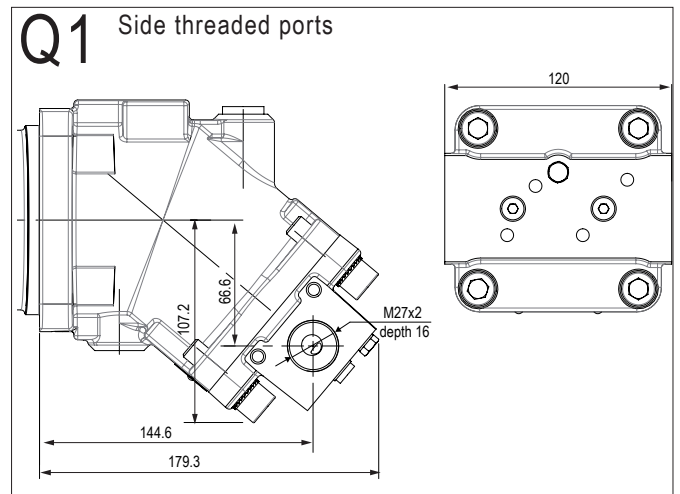
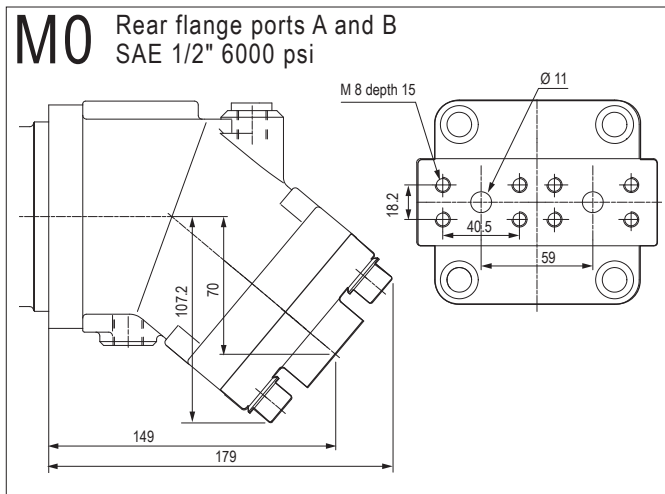
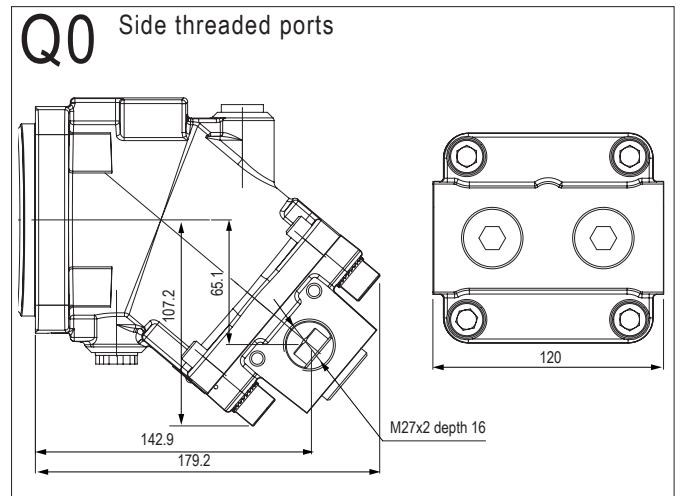
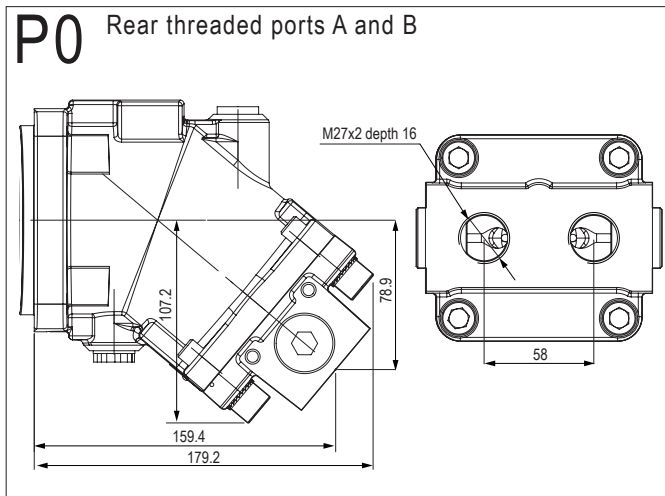

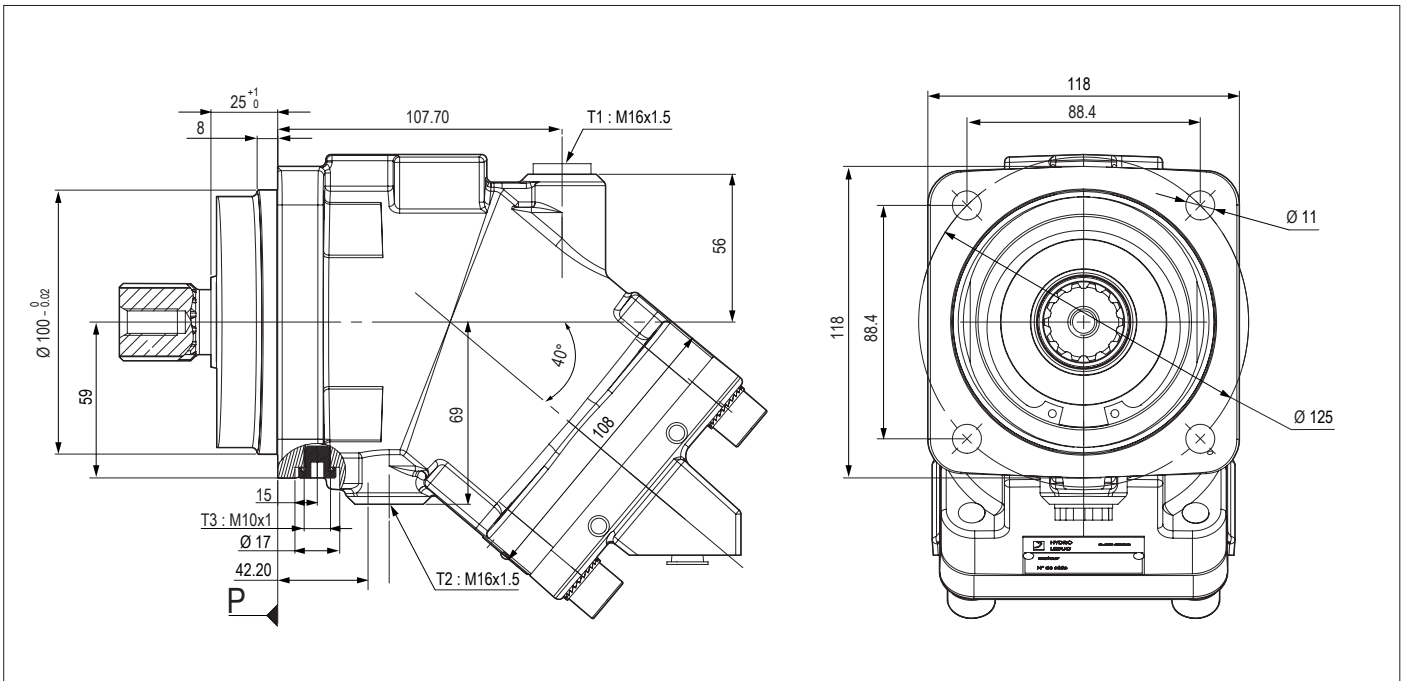

► Shaft end

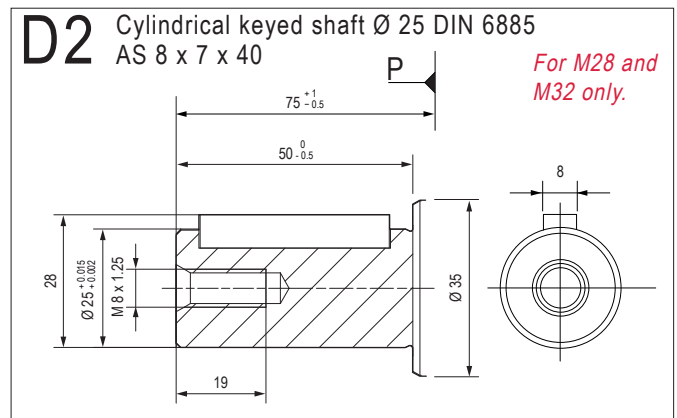
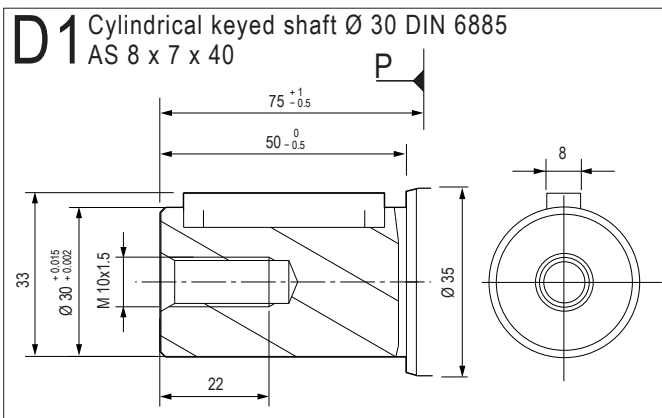
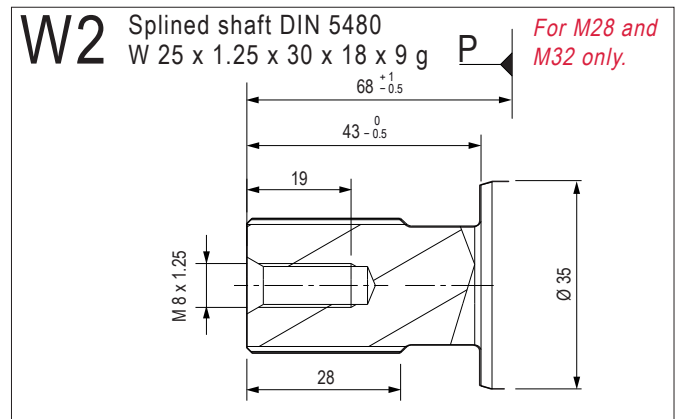
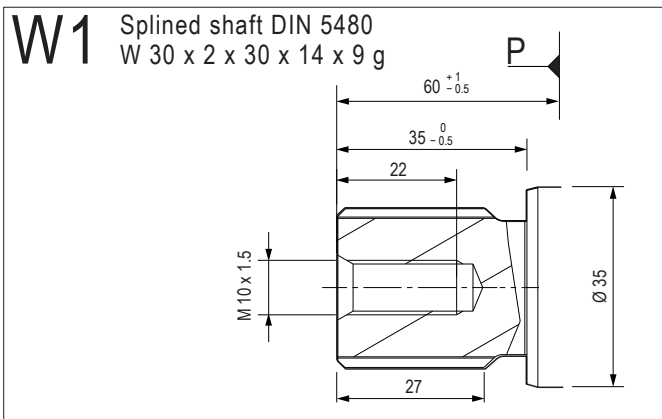

► Inlet ports

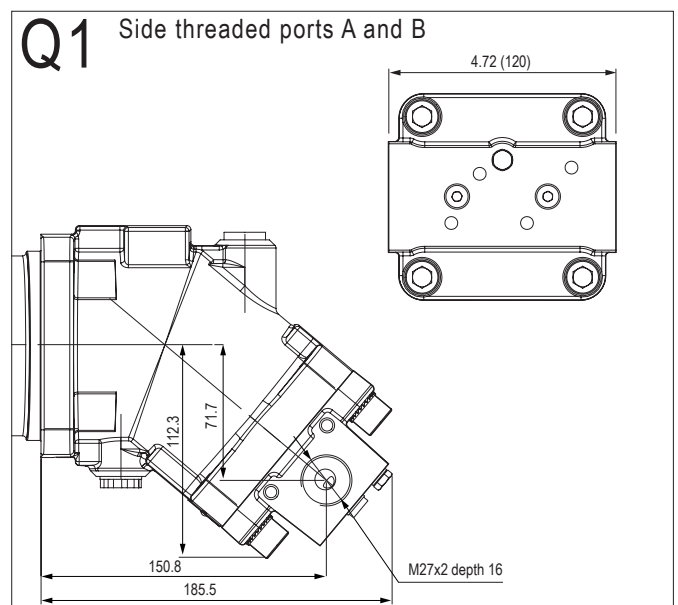
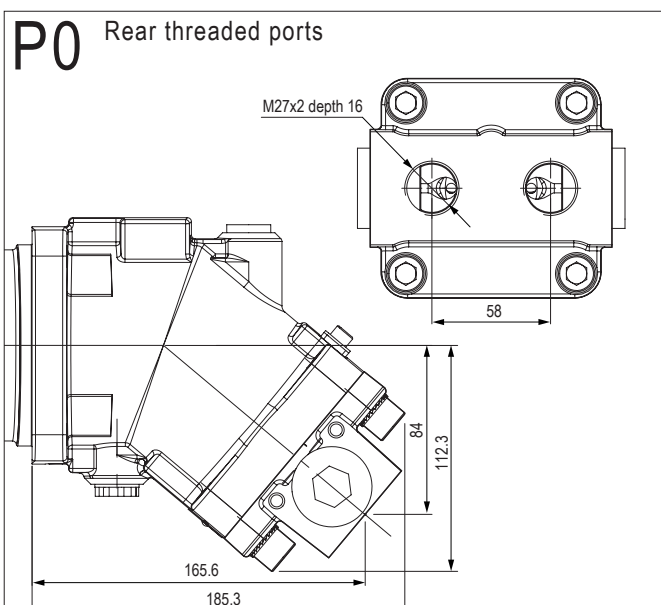
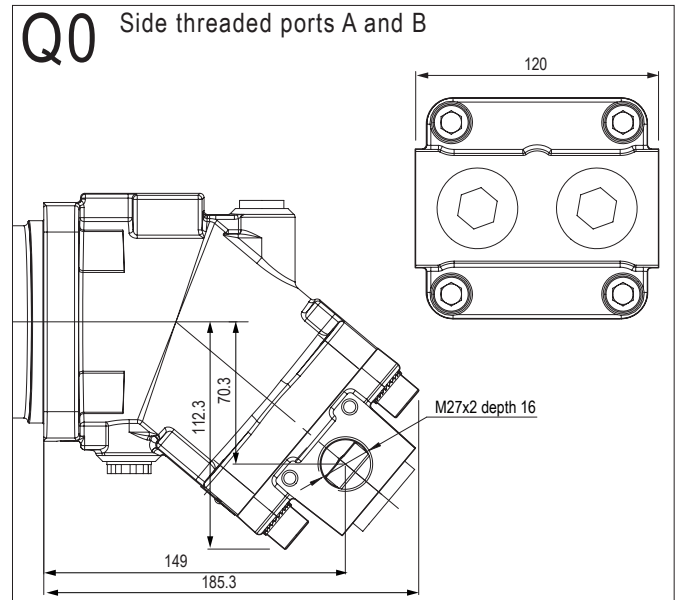
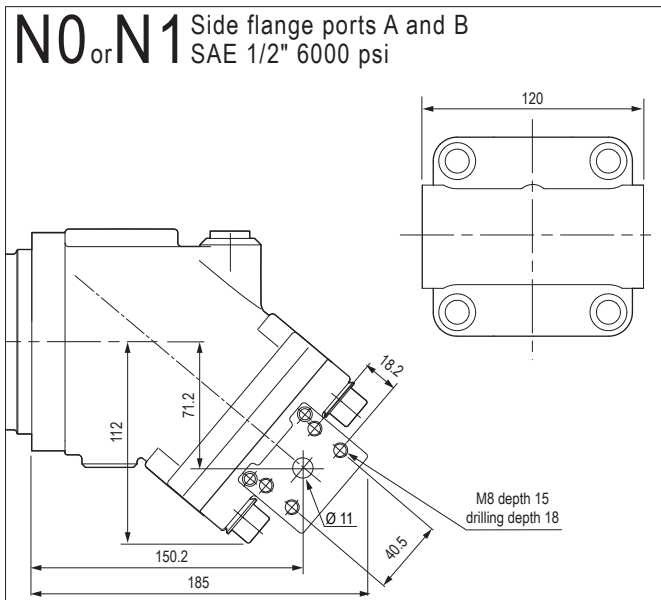
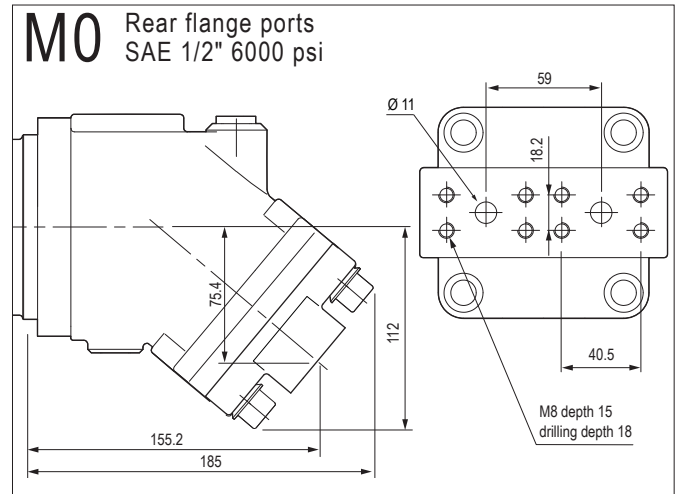
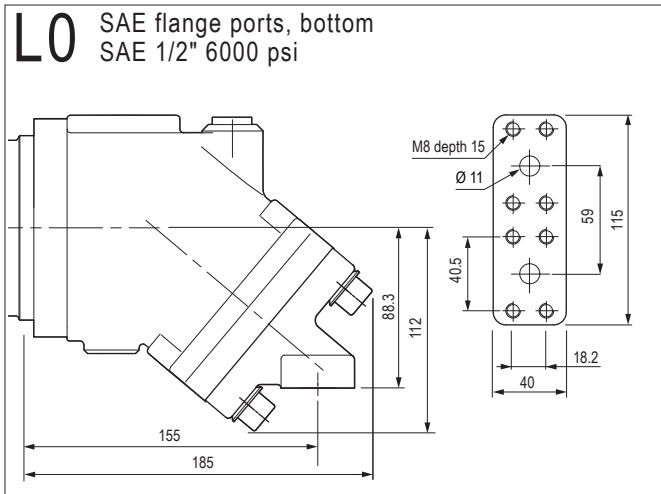

Dimensions in mm are given only as an indication.

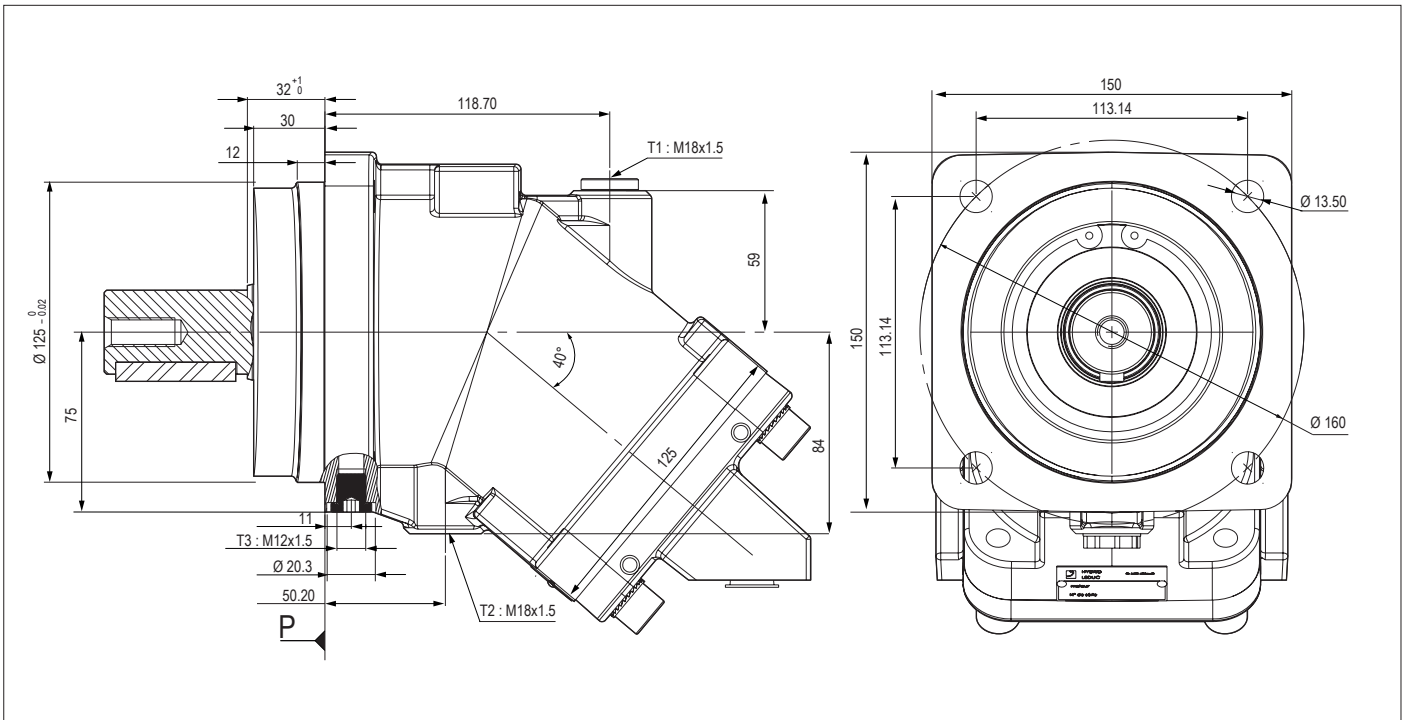

► Shaft end

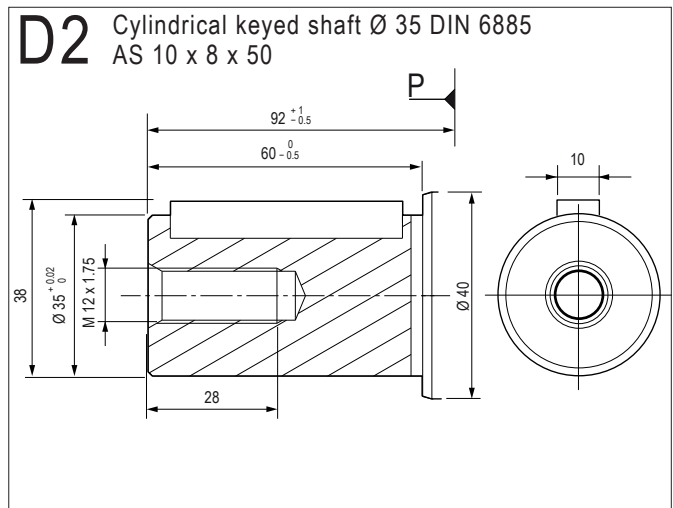
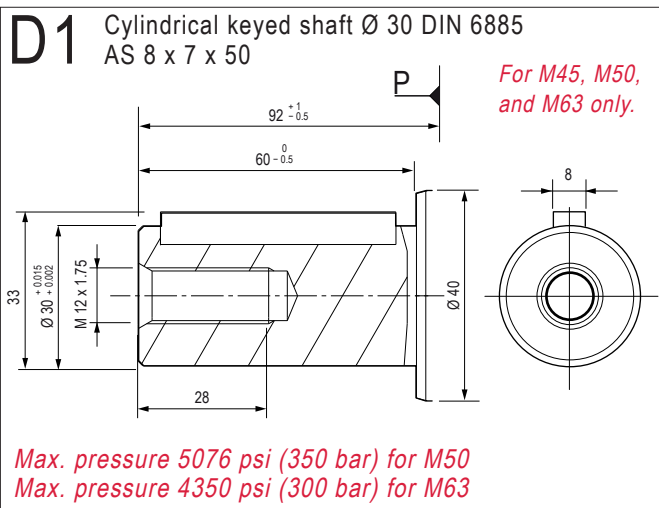
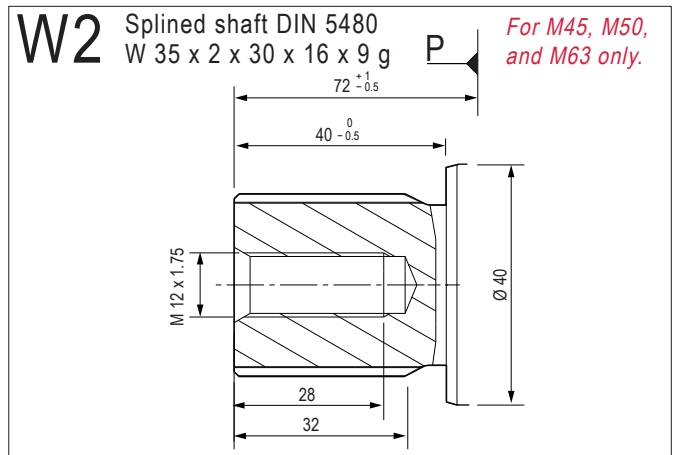
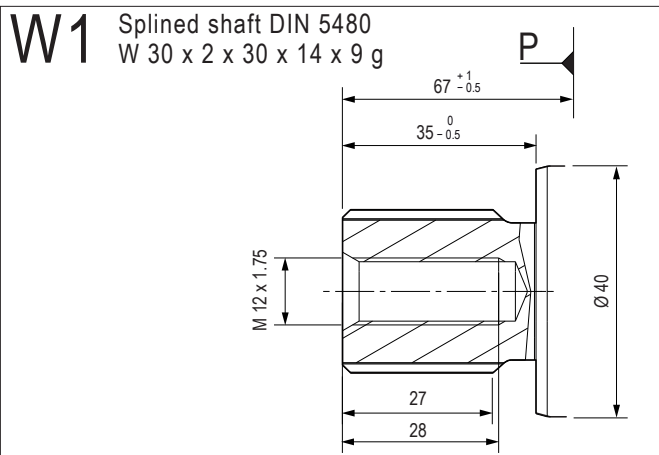

Dimensions in mm are given only as an indication.

► Inlet ports

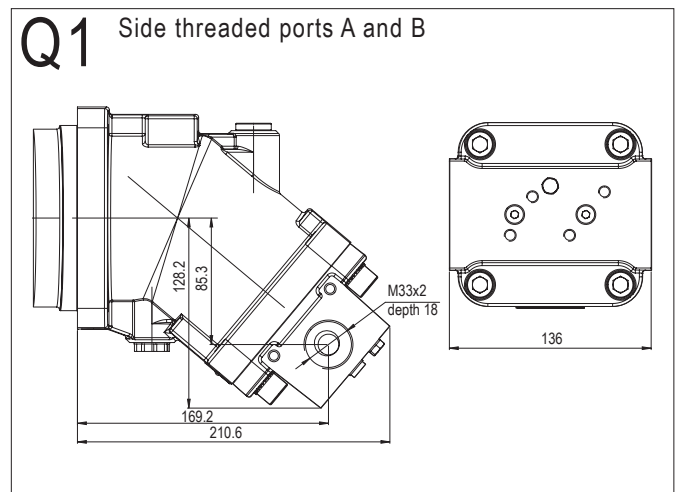
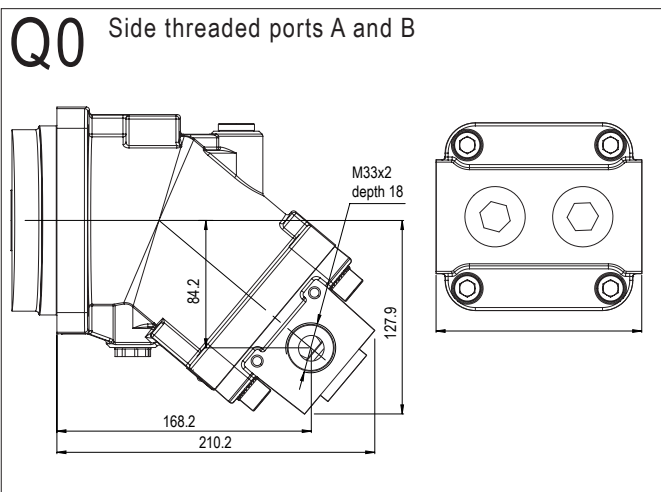
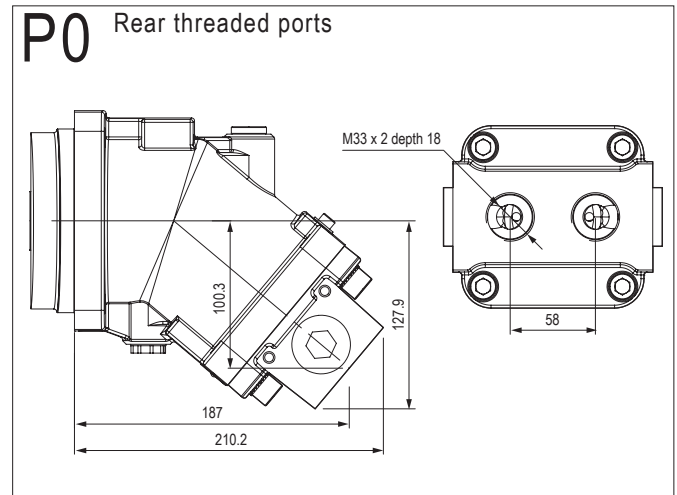
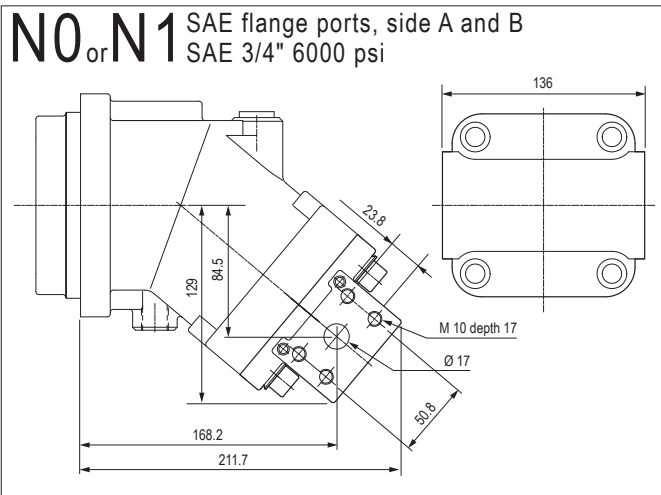
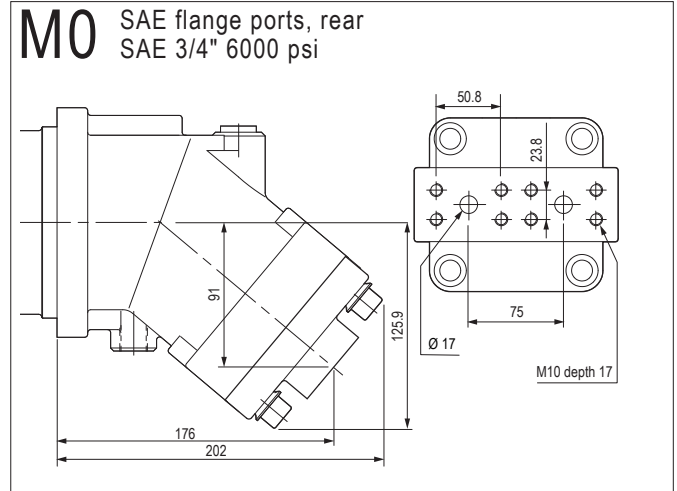
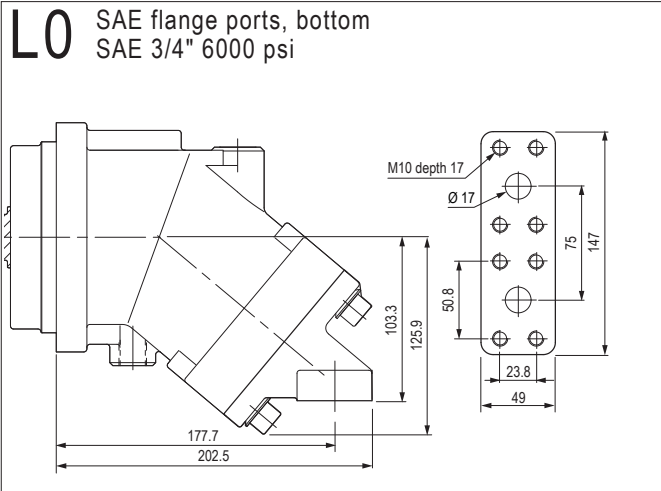

M series

► Inlet ports

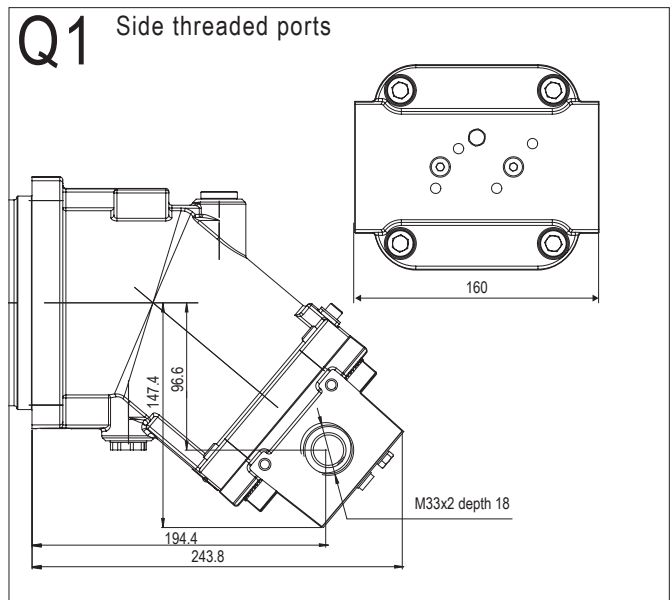
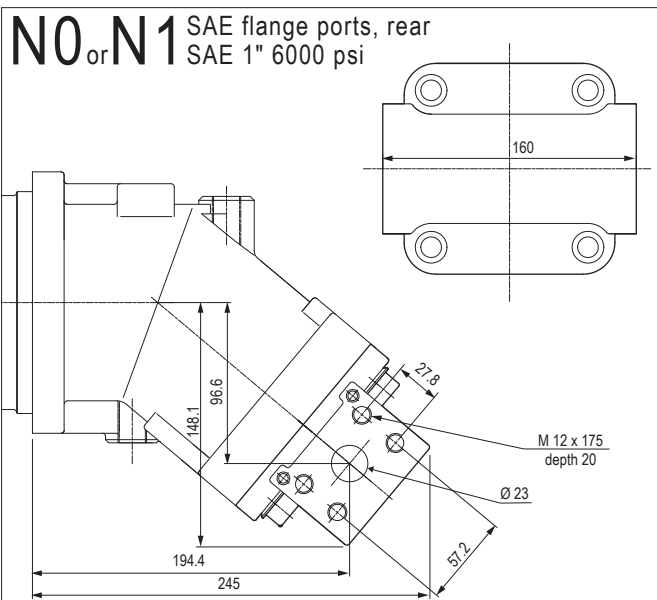
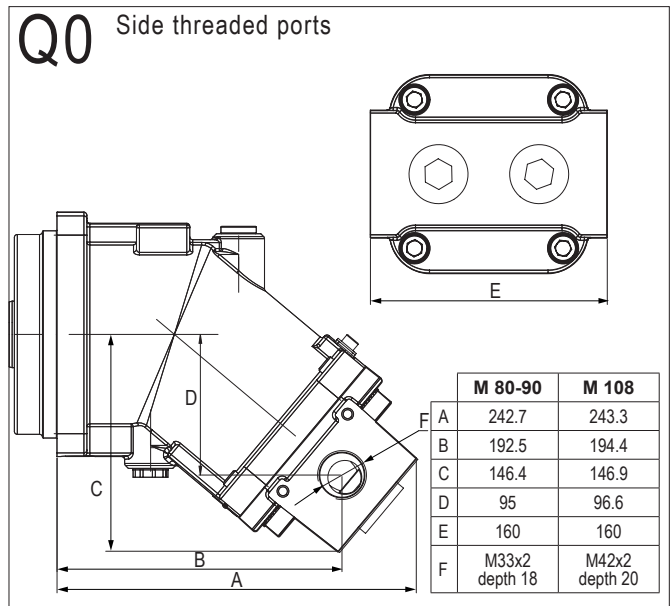
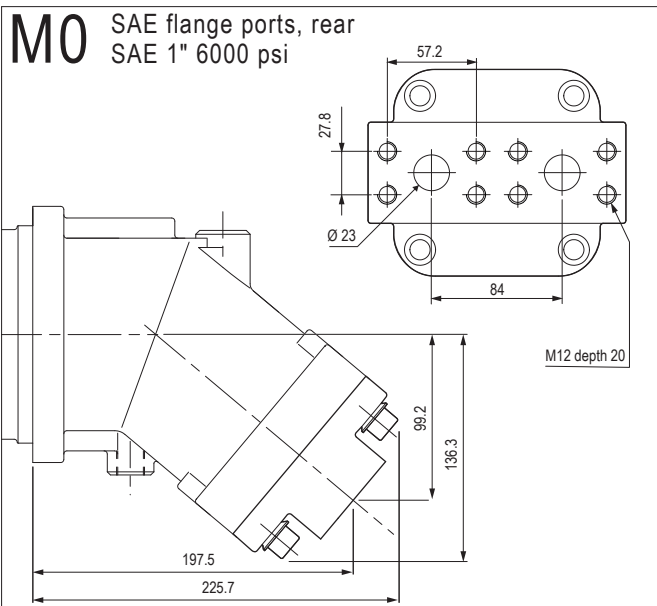
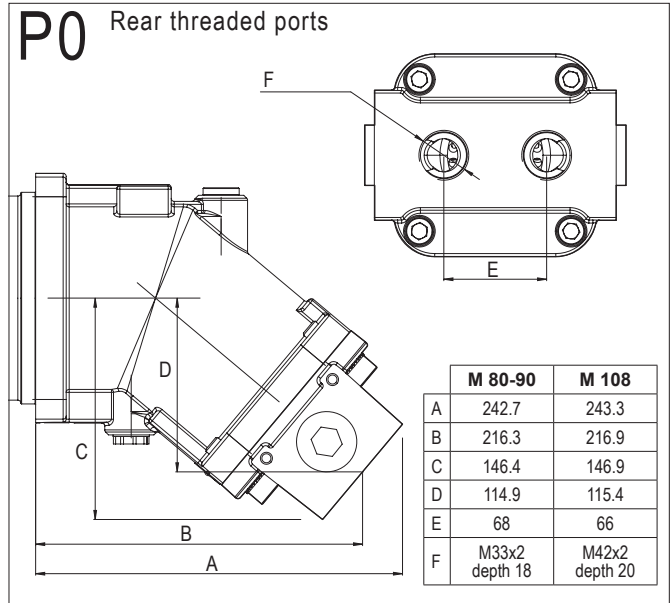
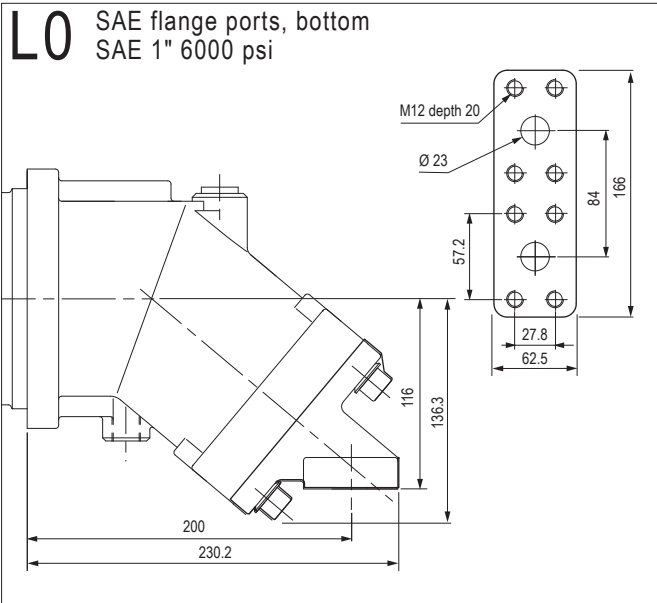

Dimensions in mm are given only as an indication.

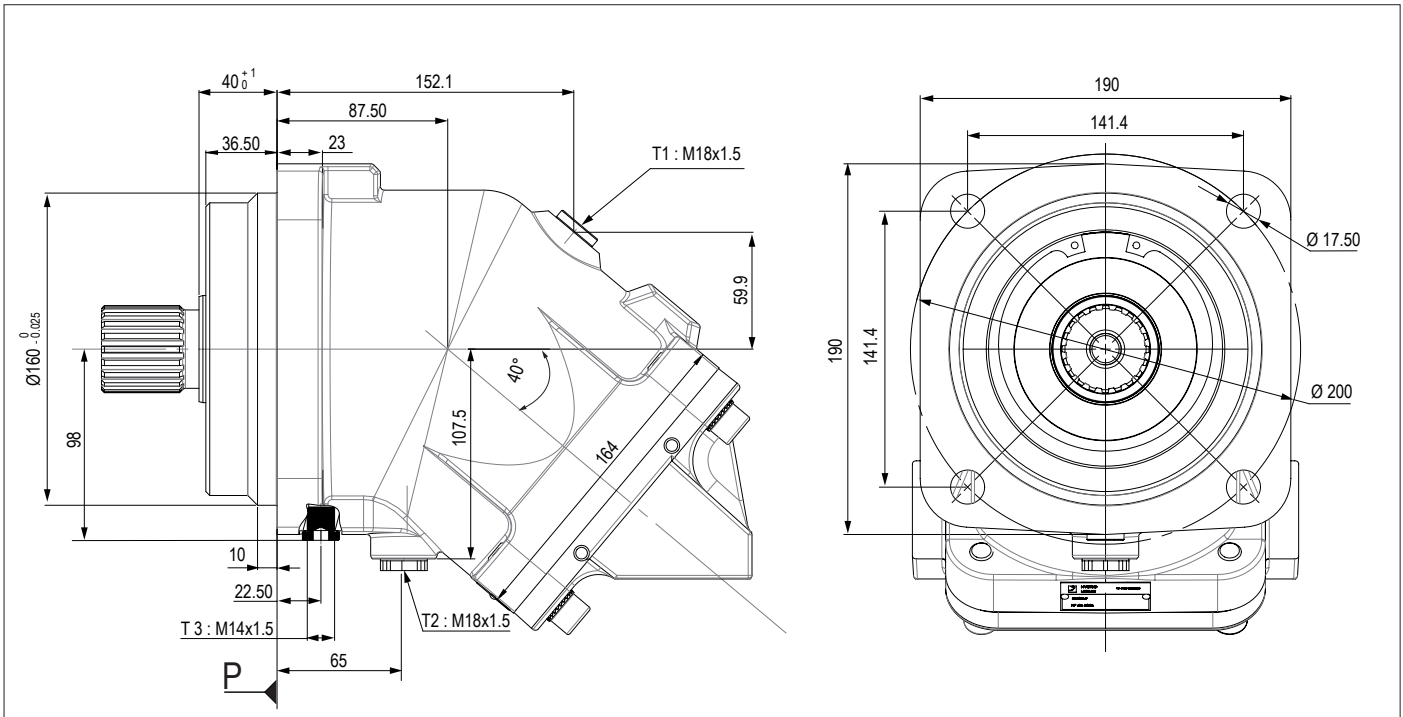

► Shaft end

W1 Splined shaft DIN 5480
W 45 x 2 x 30 x 21 x 9 g

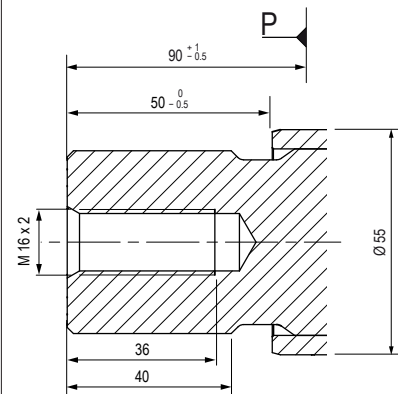

D1 Cylindrical keyed shaft $\varnothing 45$ DIN 6885
AS 14 x 9 x 63

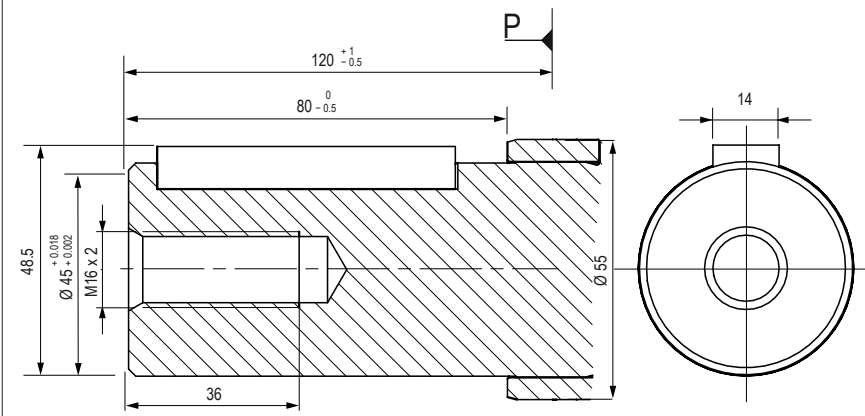

W2 Splined shaft DIN 5480
W 40 x 2 x 30 x 18 x 9 g

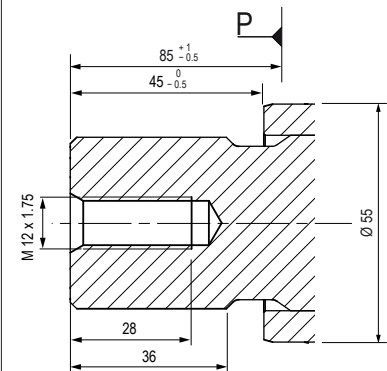

Max. pressure 5076 (350 bar) for M 125.

D2 Cylindrical keyed shaft $\varnothing 40$ DIN 6885
AS 12 x 8 x 56

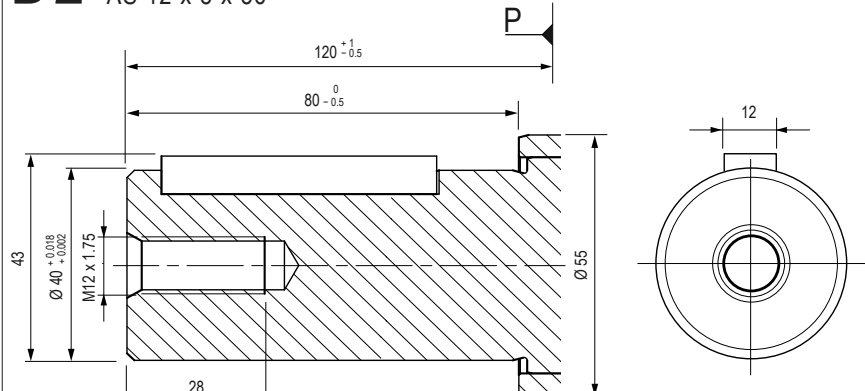

For M 108 R only.

► Inlet ports

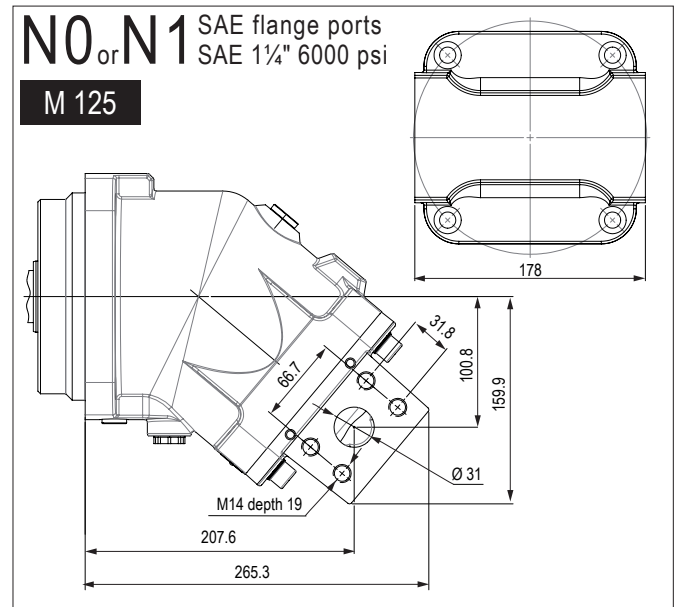
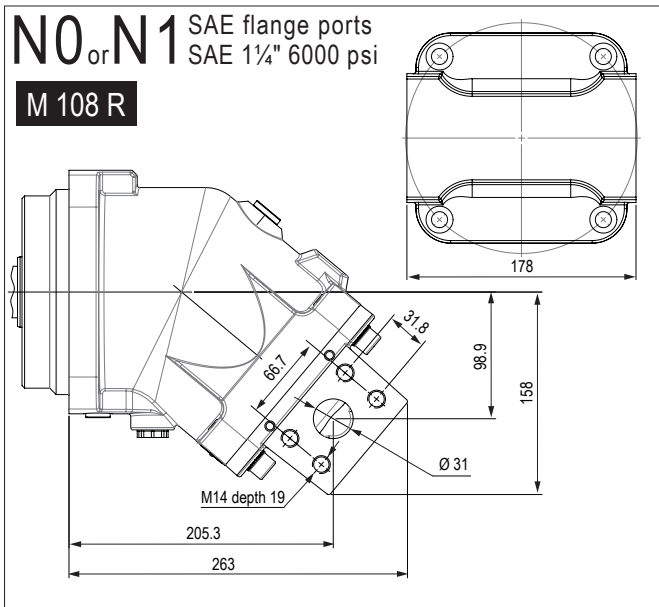
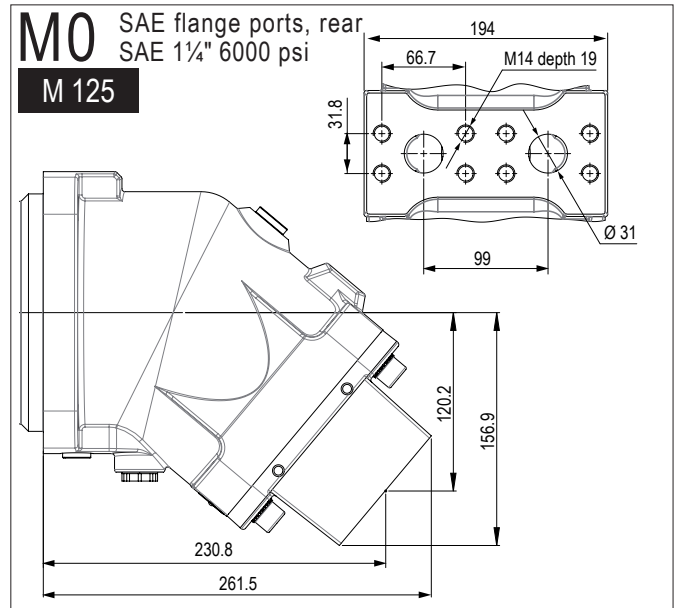
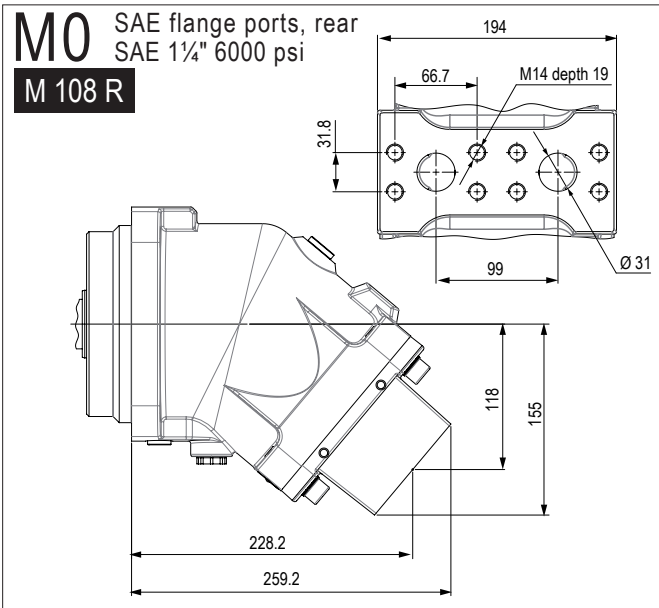
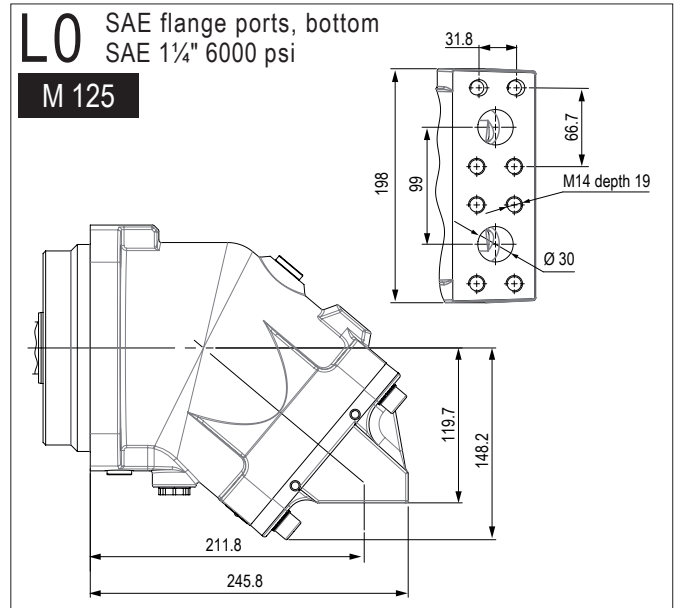
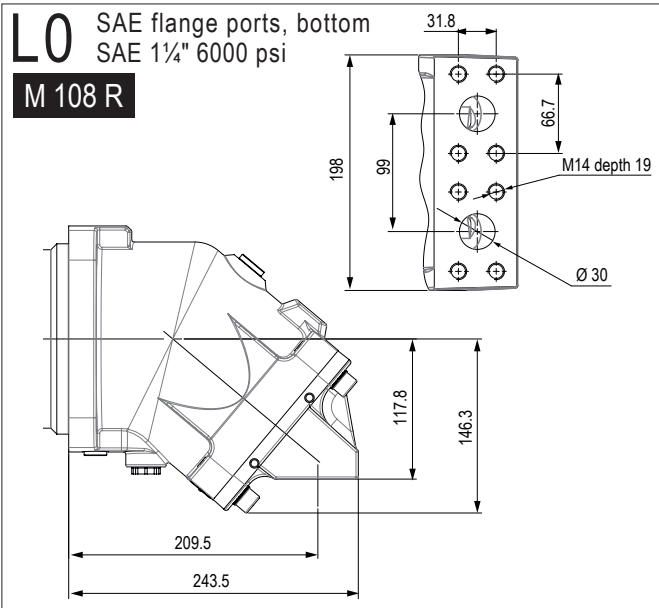

Dimensions in mm are given only as an indication.

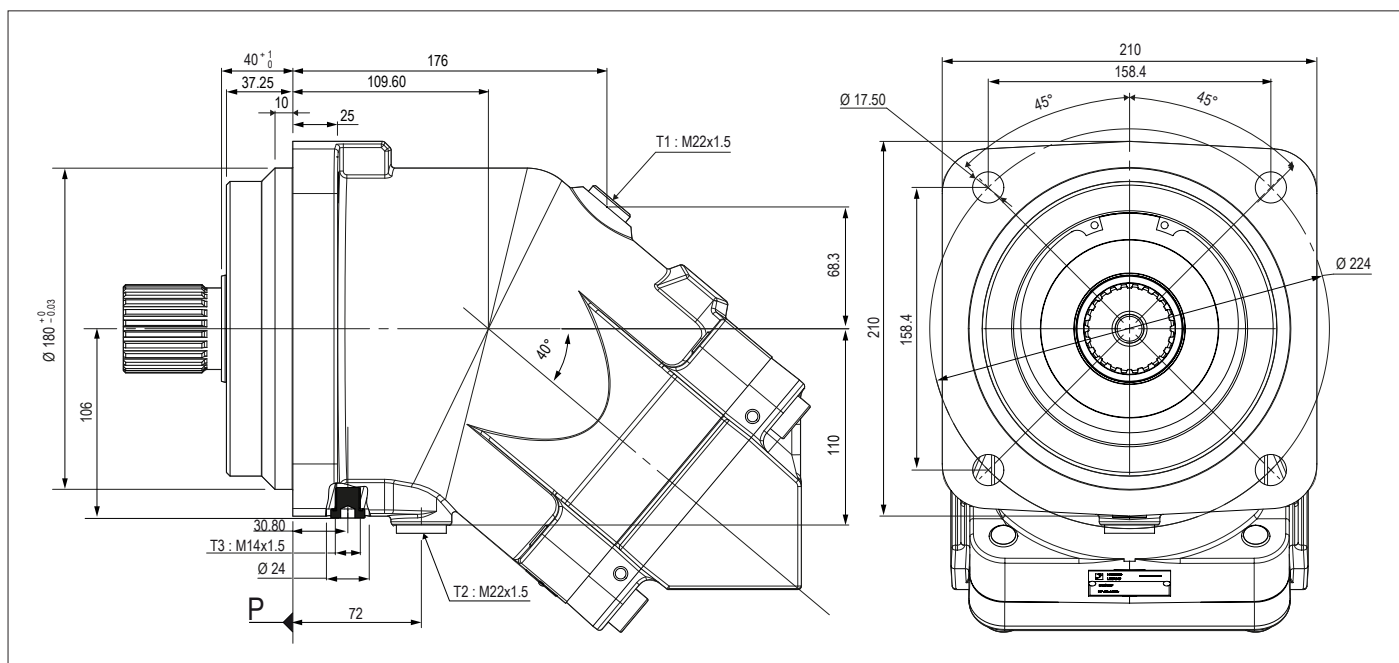

► Shaft end

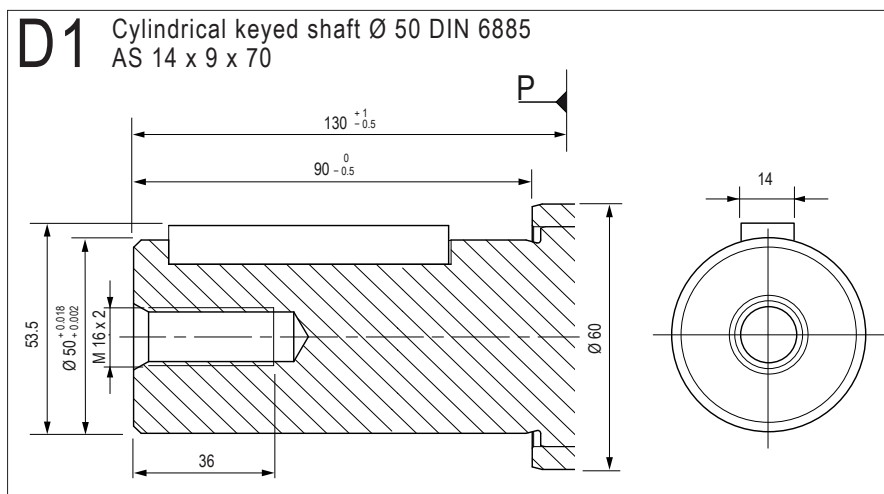
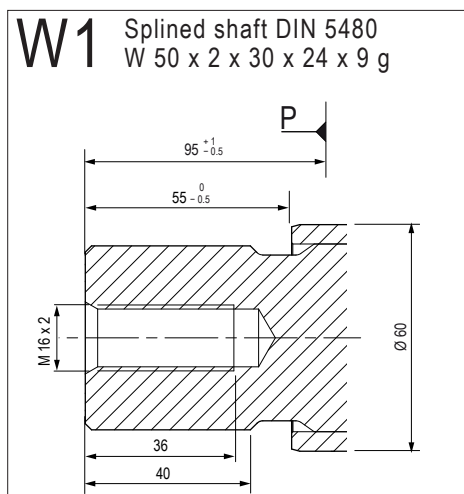

► Inlet ports

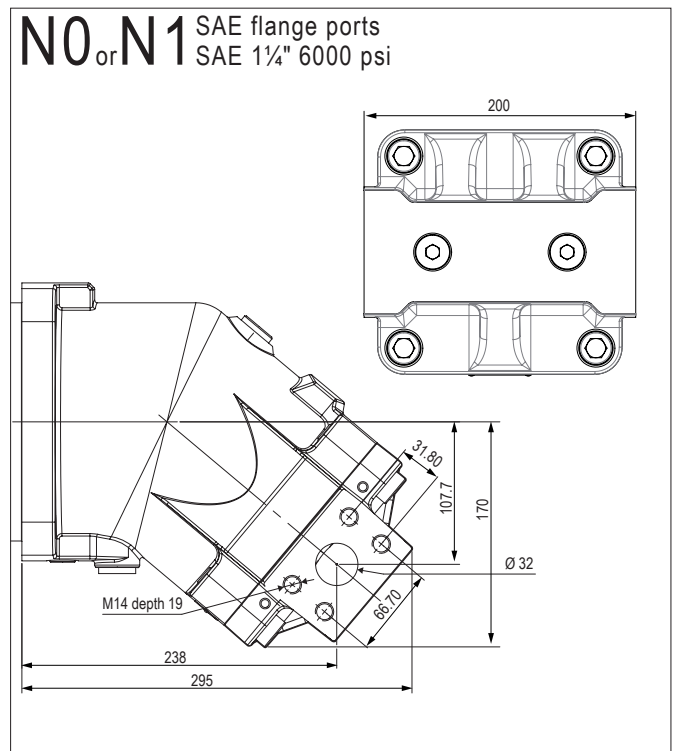
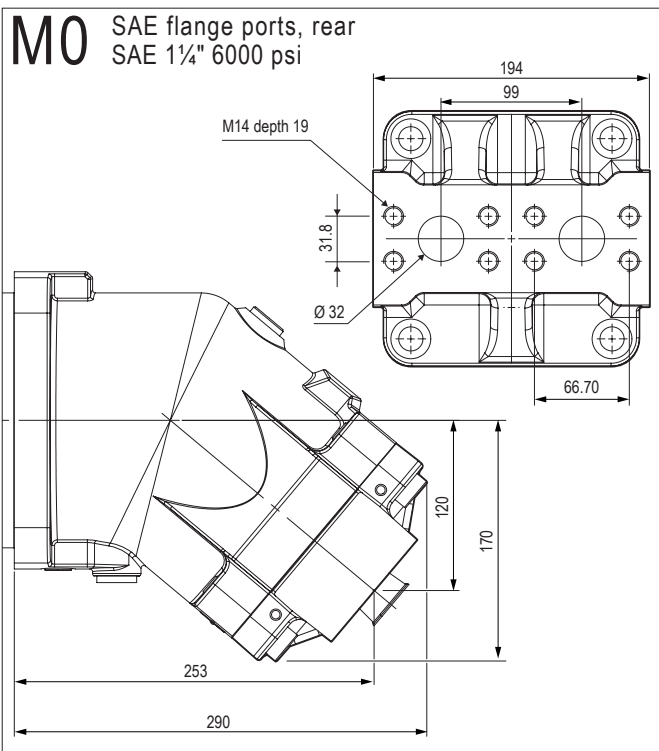
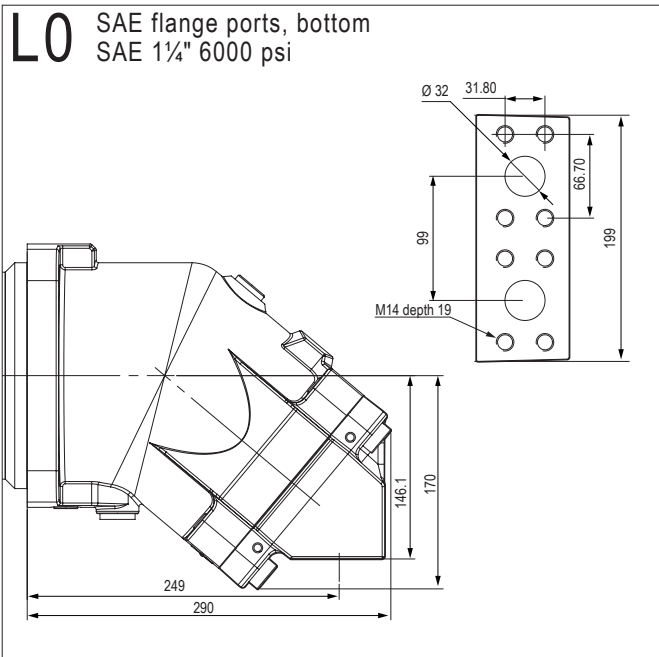

Dimensions in mm are given only as an indication.