

CHARACTERISTICS OF THE MSI SERIES MOTORS

Motor model	Displacement (cc/rev)	Continuous max. speed (1) (rpm)	Intermittent max. speed (1) (rpm)	Max. flow absorbed (l/min)	Torque (N.m/bar)	Torque at 350 bar (N.m)	Max. allowable pressure continuous / peak (bar)	Weight (kg)
MSI 28	27,7	6300	6900	175	0,44	154	400 / 450	11,5
MSI 32	32,1	6300	6900	202	0,51	179	400 / 450	11,5
MSI 41	41,1	5600	6200	230	0,65	229	400 / 450	11,5
MSI 45	45,4	5000	5500	227	0,72	253	400 / 450	17
MSI 50	50,3	5000	5500	252	0,80	280	400 / 450	19
MSI 63	63,3	5000	5500	315	1,00	351	400 / 450	19
MSI 80	80,4	4500	5000	362	1,28	448	400 / 450	26
MSI 90	90	4500	5000	405	1,43	501	400 / 450	26
MSI 108	108,3	4000	4400	433	1,72	603	400 / 450	26
MSI 108 R (2)	108,3	3400	4500	368	1,72	603	400 / 450	33
MSI 125	125,3	3400	4500	426	2,00	699	400 / 450	33
MSI 160	160,3	3600	4000	576	2,55	891	400 / 450	45,3
MSI 180	180,3	3600	4000	650	2,87	1006	400 / 450	45,3

(1) For higher speeds, please contact us.

(2) The MSI 108 R is in the frame size of the MA 125.

► Acceptable forces applied to motor shaft

Motor model	28	32	41	45	50	63	80	90	108	108 R	125	160	180	
Fr	N	6200	6500	7000	6500	7500	9000	10500	11000	11500	12500	14500	18000	20000
Fa	N/bar *	28	30	40	40	40	50	60	67	80	80	86	85	95

Fr: radial force measured at mid point of length of shaft.

Fa: axial force which tends to push the shaft inwards.

* Differential pressure between A and B.

For other forces, please contact us.

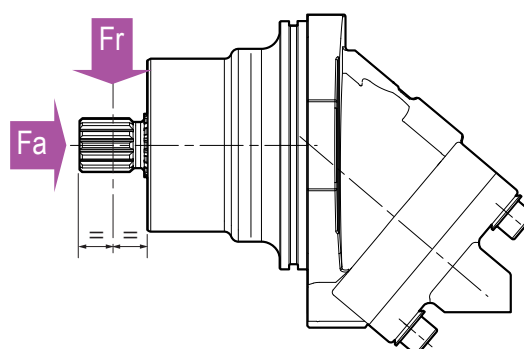
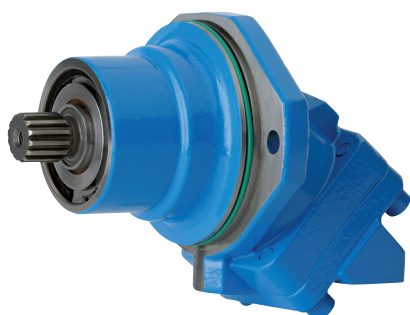

MSI	...	B	M1	SP
01	02	03	04	05	06	07	08	09	10	11

To obtain the code for your motor, complete the different parameters 02, 04, 05, 07, 08, 09 and 10, in the table on the left according to the options you require (see table below).

Motor																
01	Semi-integrated motor															MSI
Displacement																
02			28	32	41	45	50	63	80	90	108	108 R	125	160	180	
Mounting flange																
03	2 bolts ISO 3019-2															B
Shaft																
04	DIN 5480 splined	W30	W30	W30	W30	W30	W30	W30	W40	W40	W40	W45	W45	W50	W50	W1
		W25	W25	-	W35	W35	W35	W35	-	-	W40	W40	-	-	W2	
	DIN 6885 keyed	Ø30	Ø30	Ø30	Ø30	Ø30	Ø30	Ø40	Ø40	Ø40	Ø45	Ø45	Ø50	Ø50	D1	
		Ø25	Ø25	-	Ø35	Ø35	Ø35	-	-	-	Ø40	-	-	-	D2	
Inlet ports A and B																
05	SAE flange ports	Bottom	0	•	•	•	-	•	•	•	•	•	•	•	•	L0
		Rear	0	•	•	•	-	•	•	•	•	•	•	•	•	M0
		Side	0	•	•	•	-	•	•	•	•	•	•	•	•	•
	1		•	•	•	-	•	•	•	•	•	•	•	•	•	N1
	Threaded	Side	0	•	•	•	-	•	•	•	•	-	-	-	-	Q0
			1	•	•	•	-	•	•	•	•	-	-	-	-	Q1
Rear		0	•	•	•	-	•	•	•	•	-	-	-	-	P0	
			0 = Without suitability for valves 1 = Compatible with flushing valve													
Drain ports T1 and T2																
06		1	1	1	1	1	1	1	1	1	1	1	1	1	1	M1
Suitable for use of speed sensor																
07	Yes	•	•	•	•	•	•	•	•	•	•	•	•	•	•	1
	No	•	•	•	•	•	•	•	•	•	•	•	•	•	•	0
Speed sensor																
08	1 frequency signal		•	•	•	•	•	•	•	•	•	•	•	•	•	1
	1 signal with connector		•	•	•	•	•	•	•	•	•	•	•	•	•	1P
	2 signals with connector		•	•	•	•	•	•	•	•	•	•	•	•	•	2P
	No		•	•	•	•	•	•	•	•	•	•	•	•	•	0
Flushing valve																
09	Without		•	•	•	•	•	•	•	•	•	•	•	•	•	SV
	Flow rate	4,25 l/min*	•	•	•	•	•	•	•	•	•	•	•	•	•	VB04
		10 l/min*	•	•	•	•	•	•	•	•	•	•	•	•	•	VB10
		14 l/min*	•	•	•	•	•	•	•	•	•	•	•	•	•	VB14
Low temperature option																
10	Yes (NBR)		•	•	•	•	•	•	•	•	•	•	•	•	•	N
	No (FKM)		•	•	•	•	•	•	•	•	•	•	•	•	•	F

Légende:
 • Existing model
 – Not yet existing

*(Δp = 25 bar)

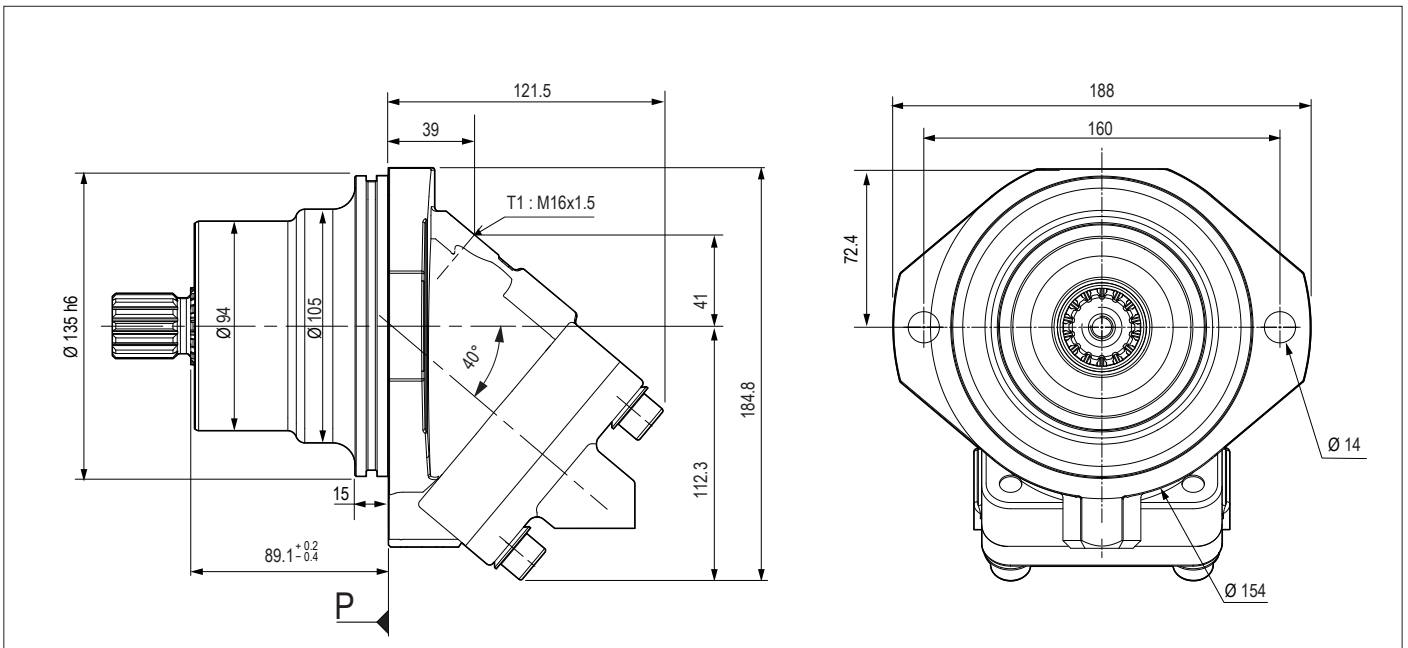

► Shaft end

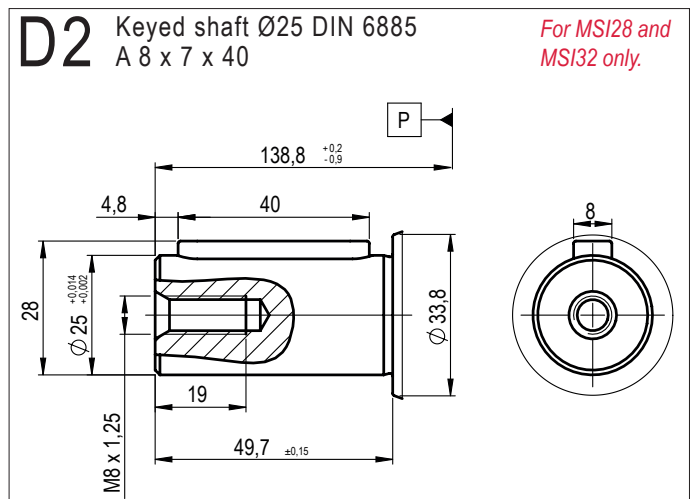
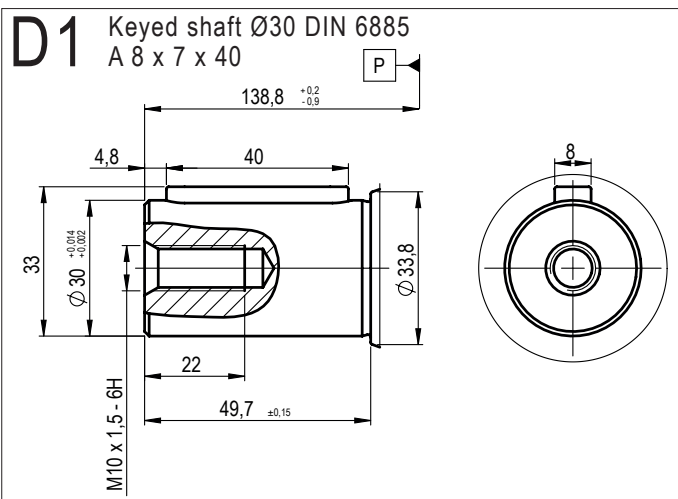
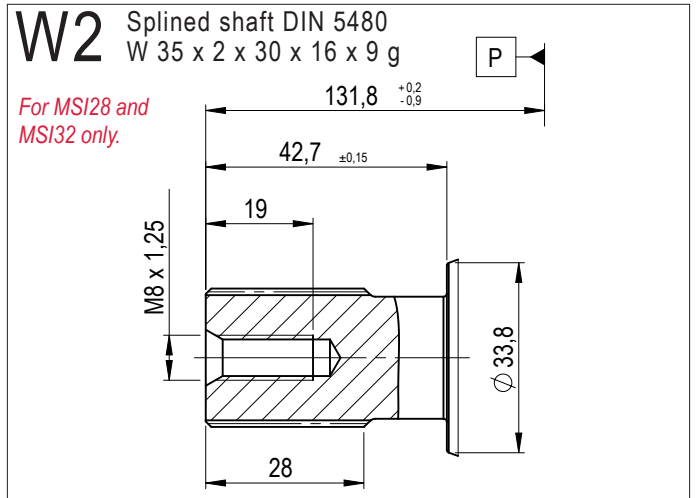
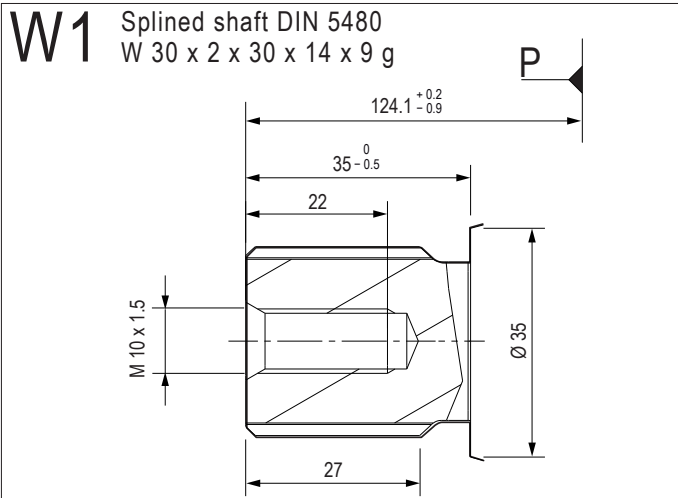

► Inlet ports

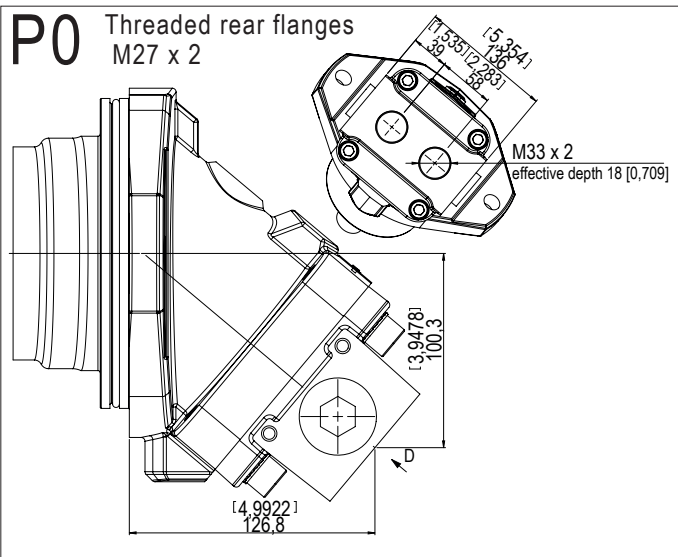
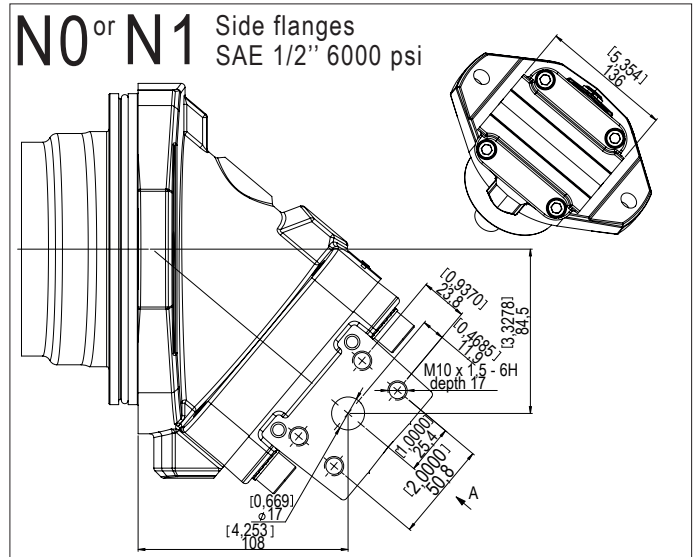
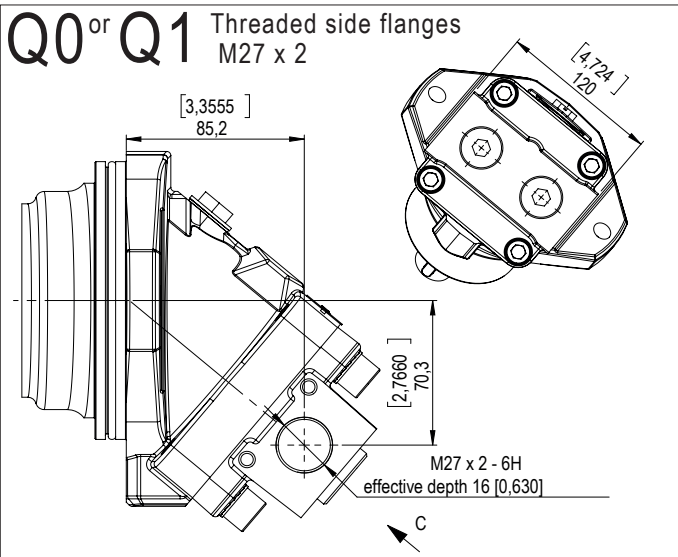
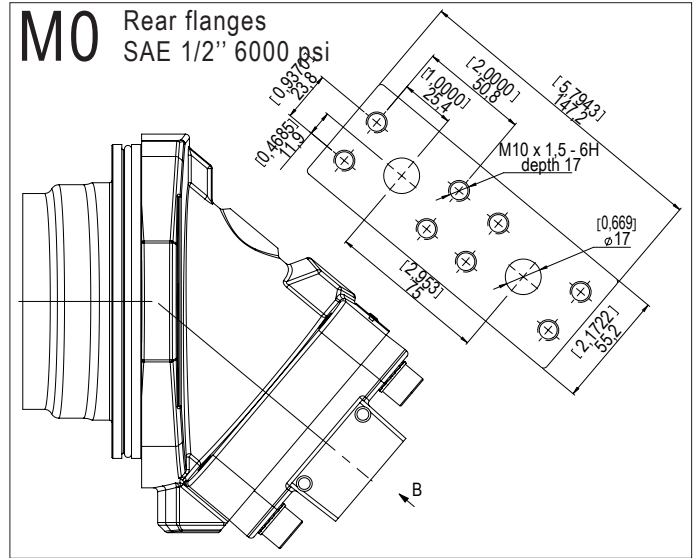
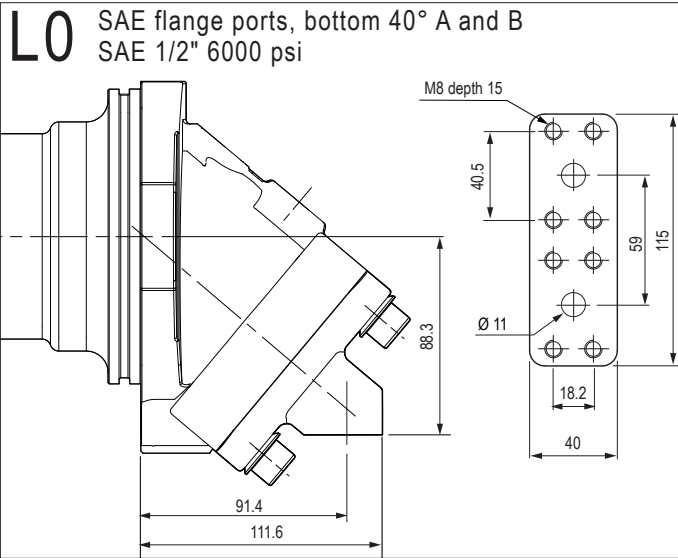

Dimensions are given only as an indication. Measurements in mm and [inches].

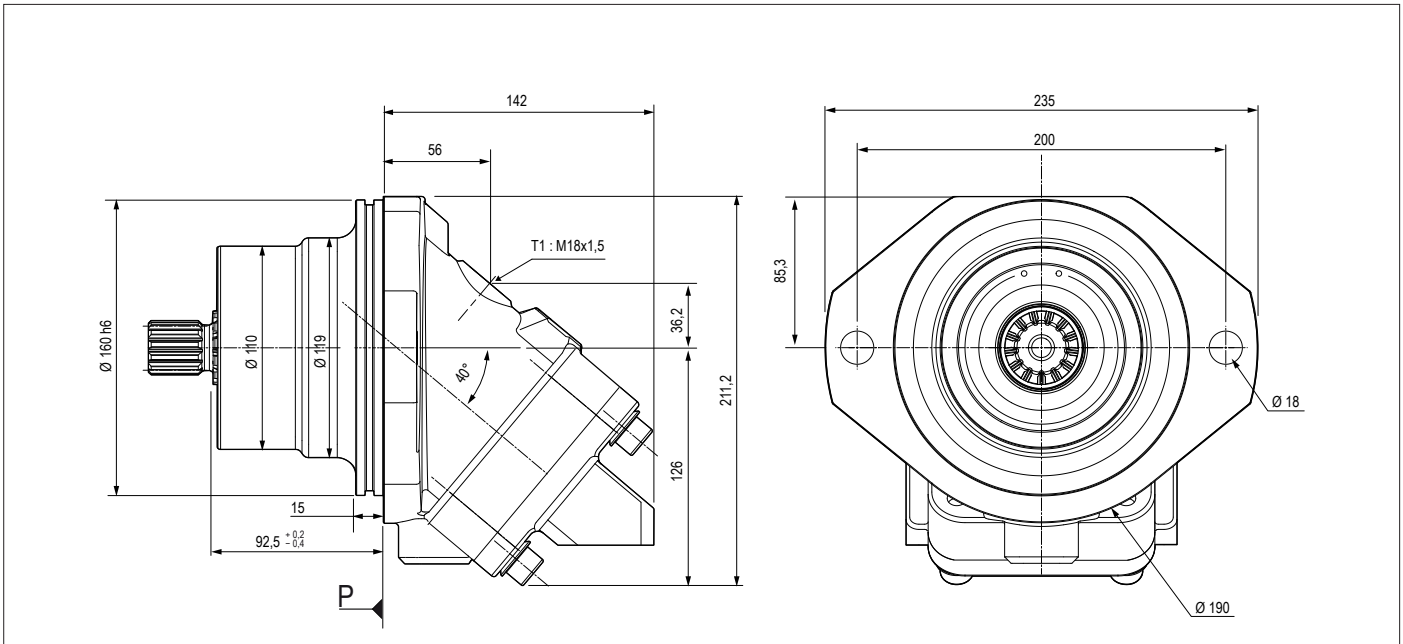

► Shaft end

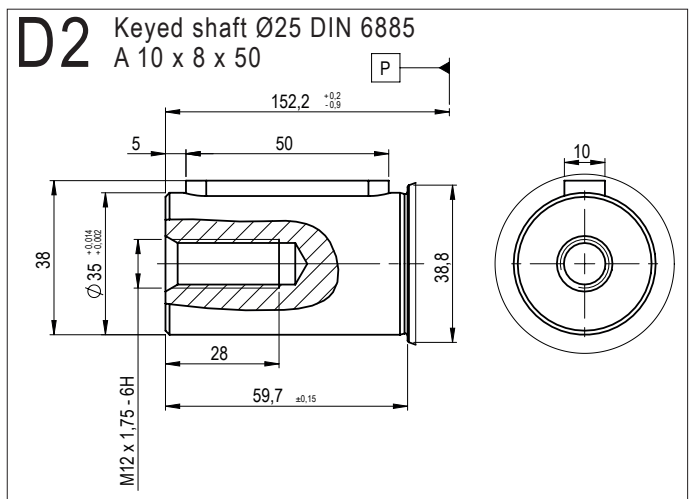
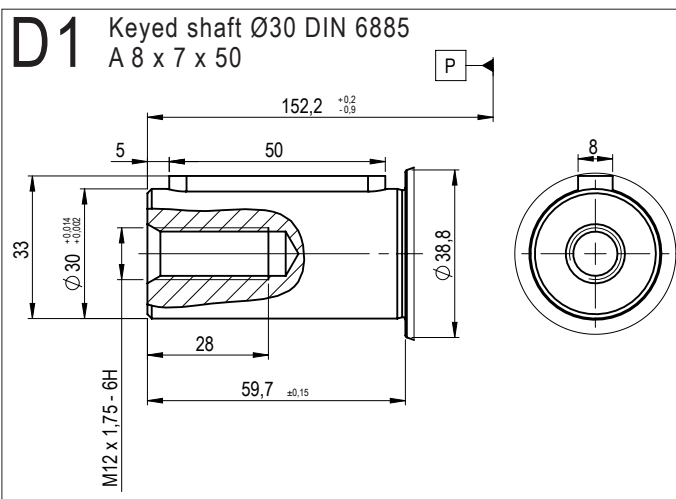
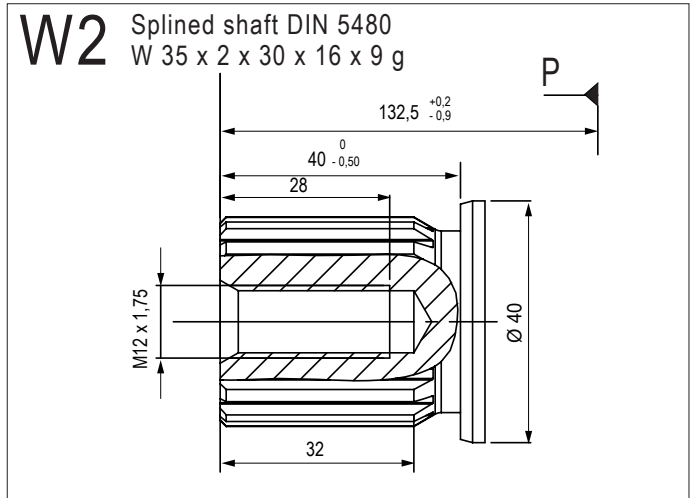
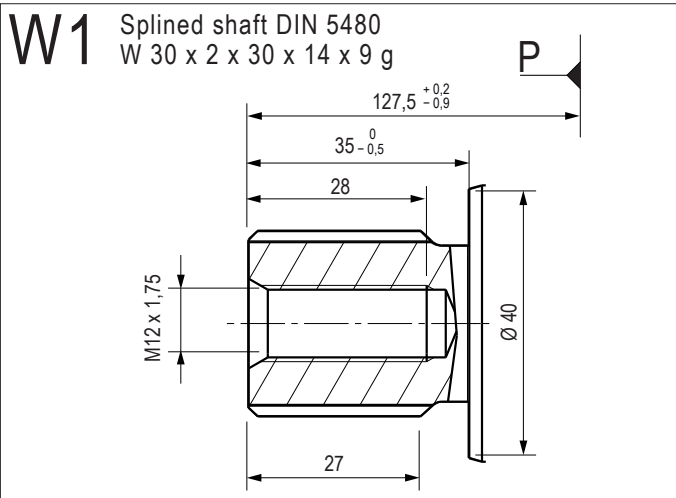

► Inlet ports

L0 Bottom flanges
SAE 3/4" 6000 psi

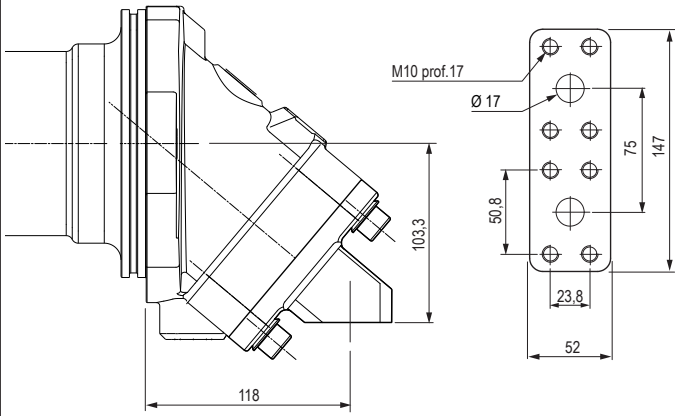

M0 Rear flanges
SAE 3/4" 6000 psi

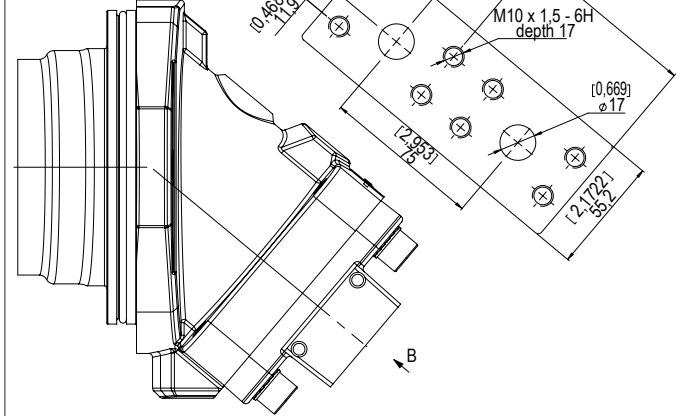

Q0 or Q1 Threaded side flanges
M33 x 2

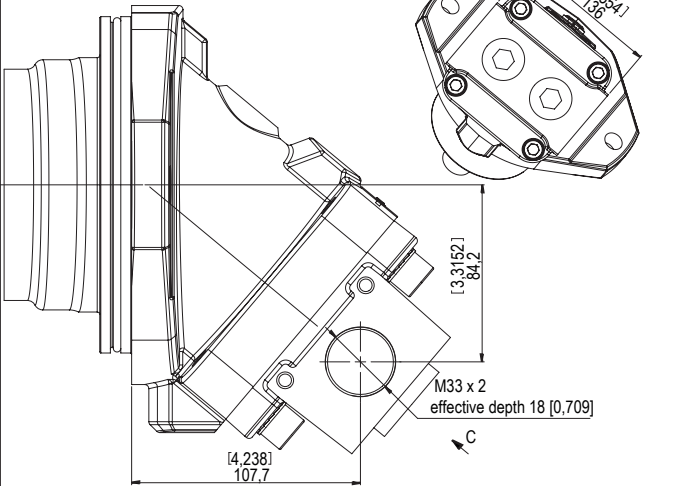

N0 or N1 Side flanges
SAE 3/4" 6000 psi

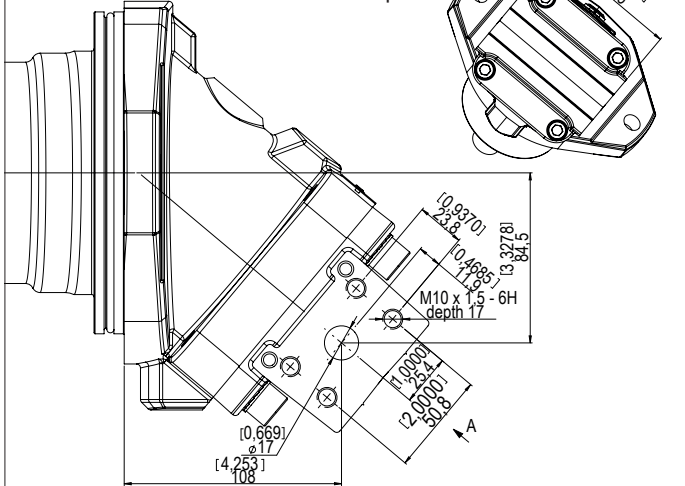

P0 Threaded rear flanges
M33 x 2

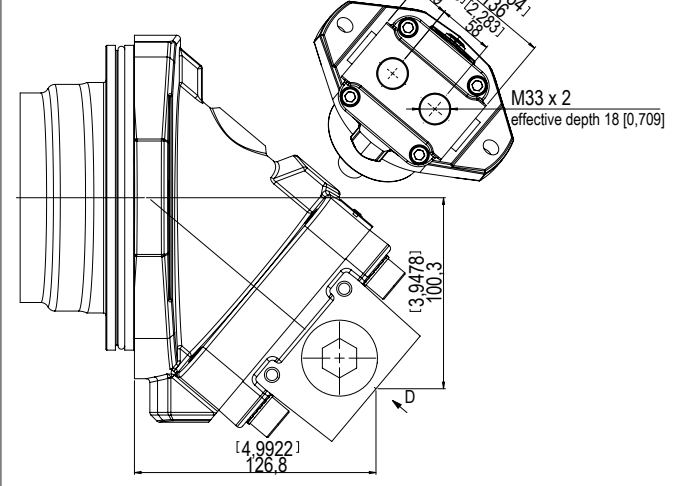

Dimensions are given only as an indication. Measurements in mm and [inches].

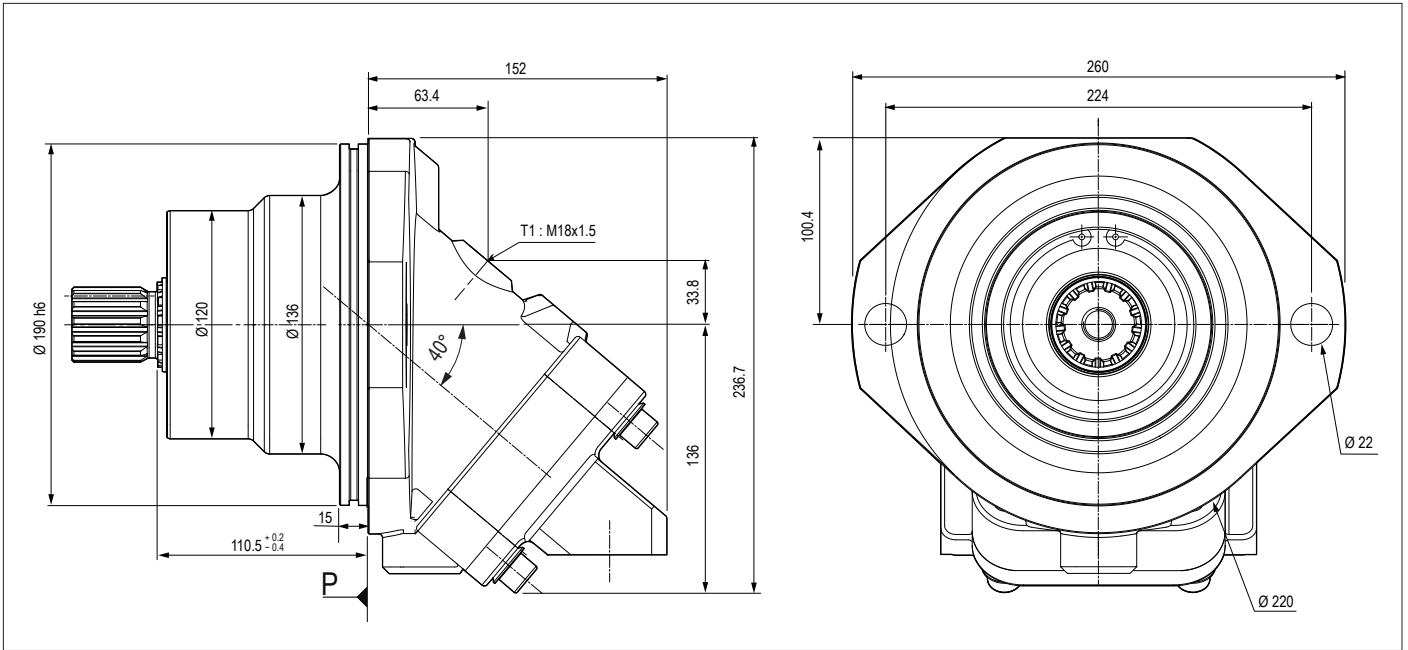

► Shaft end

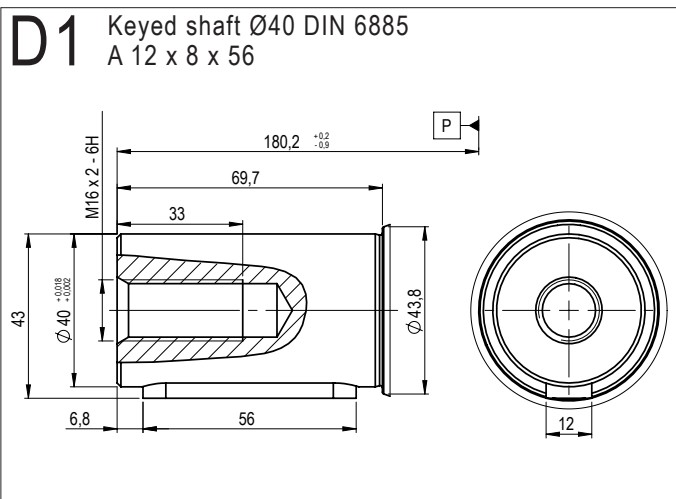
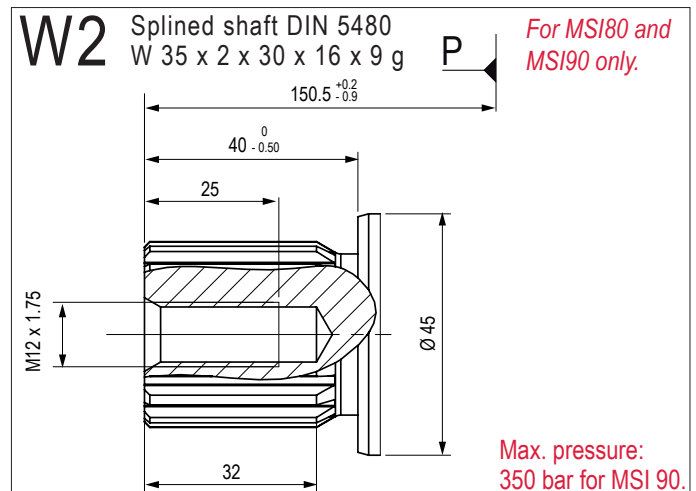
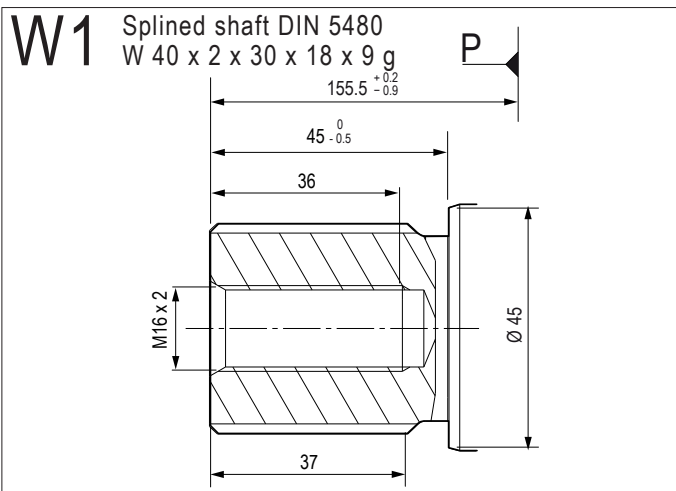

► Inlet ports

L0 SAE flange ports, bottom 40° A and B
SAE 1" 6000 psi

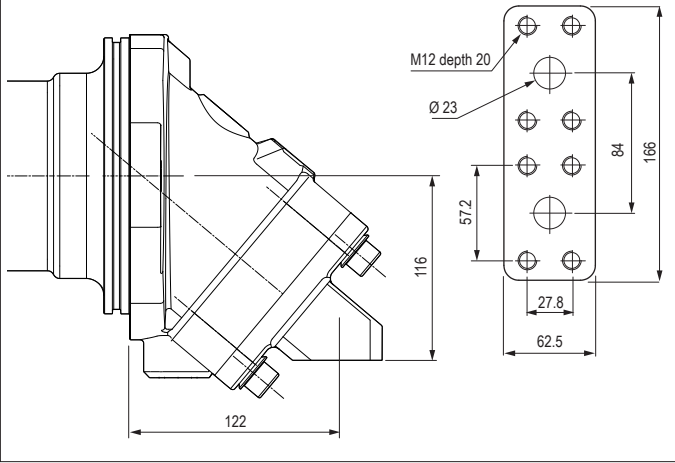

M0 Rear flanges
SAE 1" 6000 psi

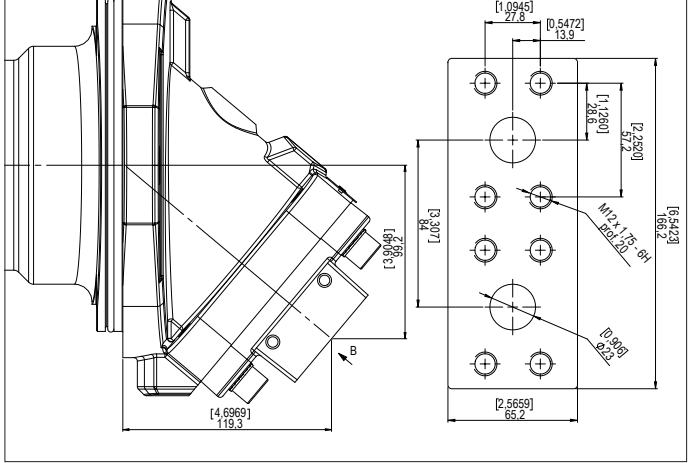

Q0 or Q1 Threaded side flanges

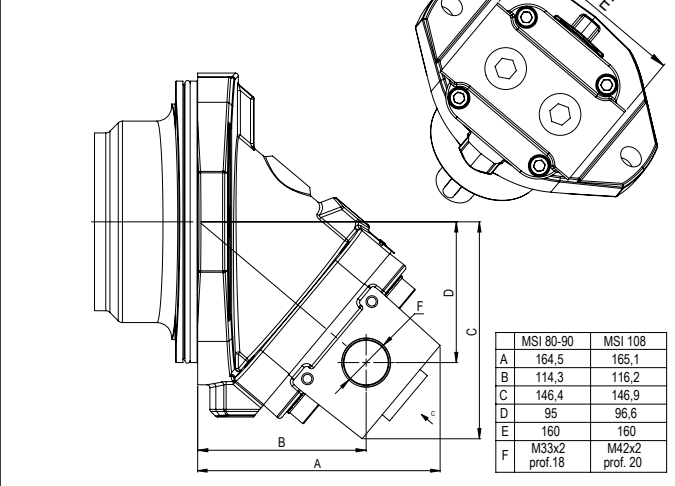

N0 or N1 Side flanges
SAE 1" 6000 psi

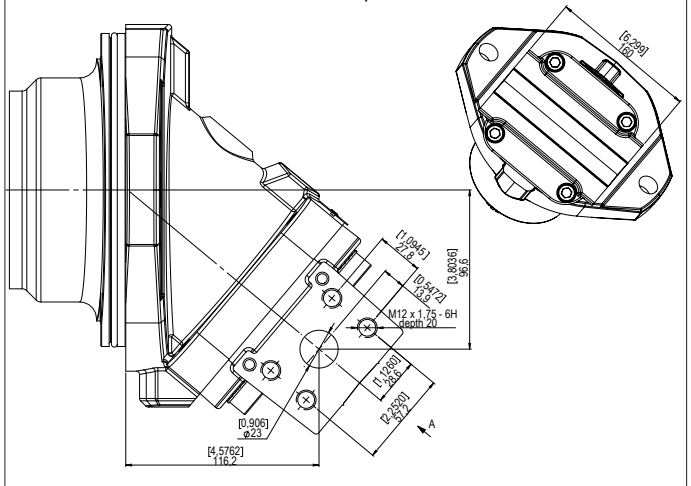

P0 Threaded rear flanges

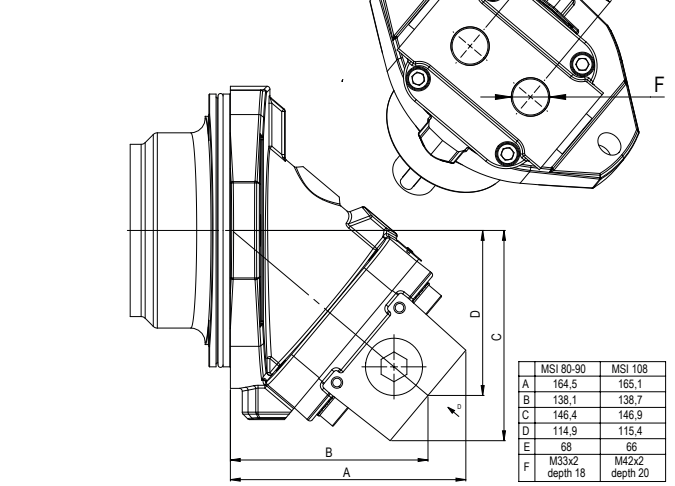

Dimensions are given only as an indication. Measurements in mm and [inches].

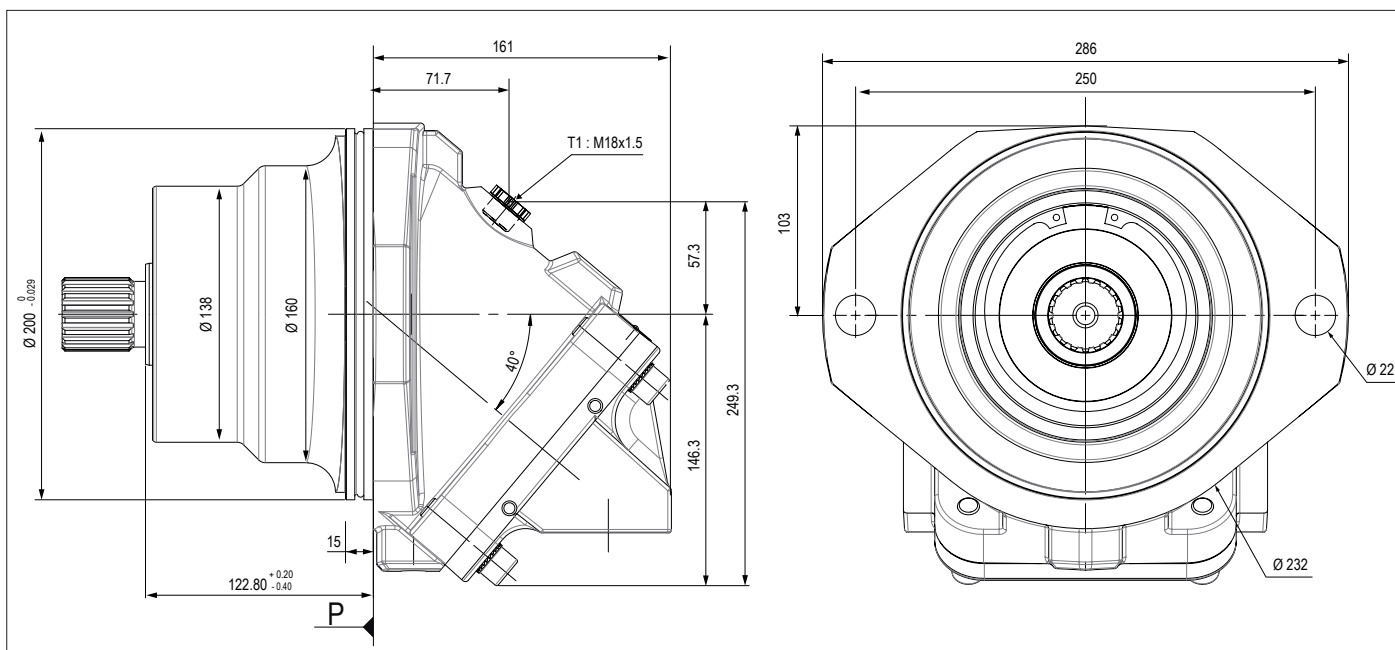

► Shaft end

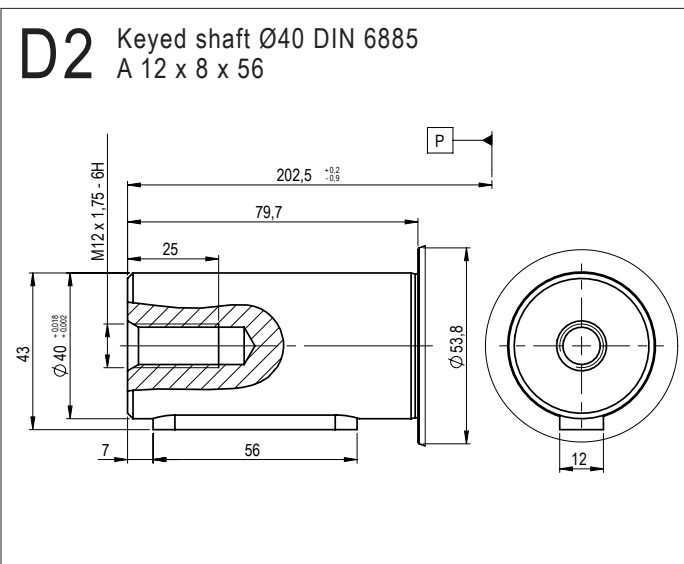
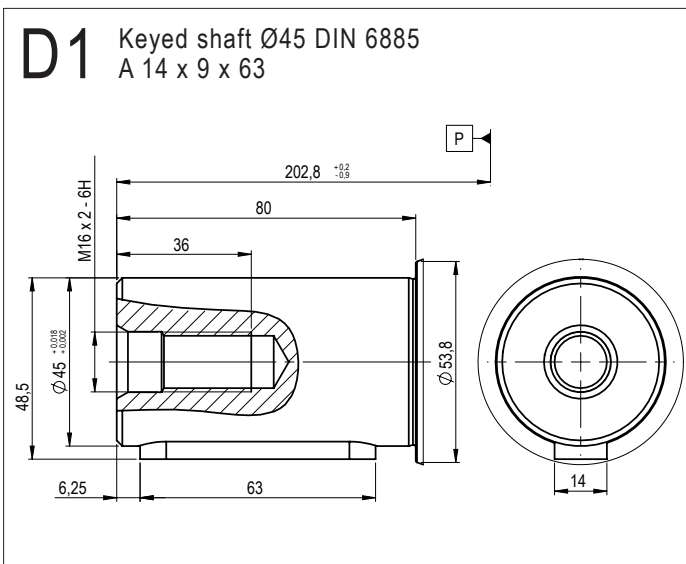
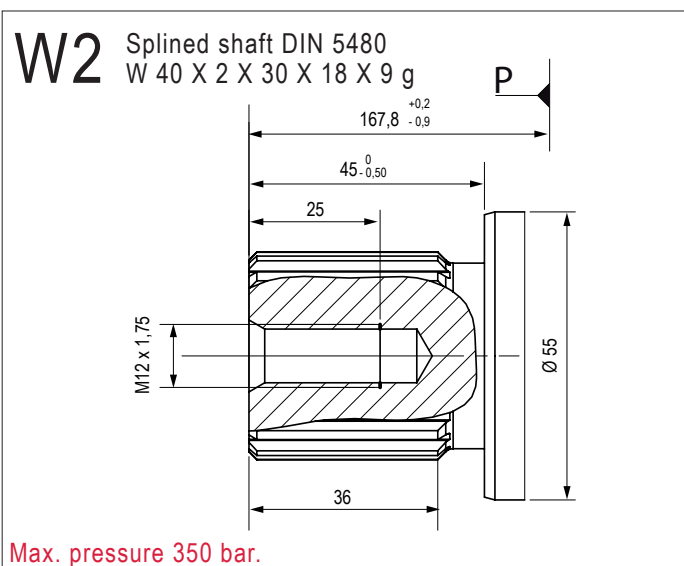
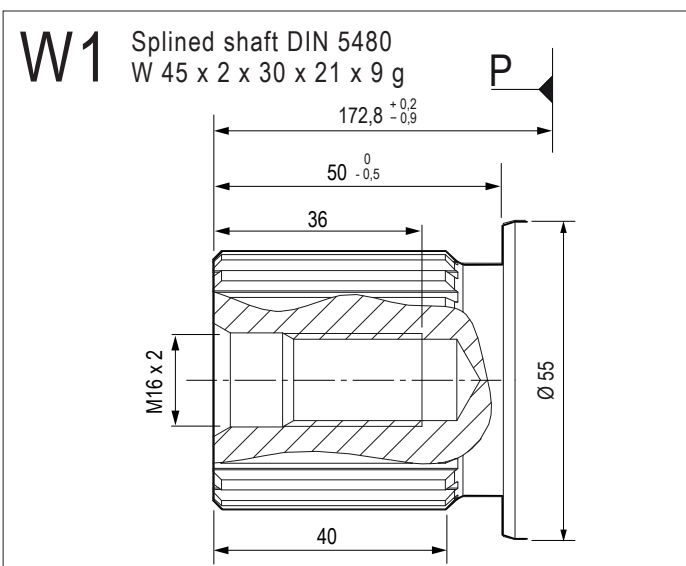

Dimensions are given only as an indication. Measurements in mm and [inches].

► Inlet ports

L0 SAE flange ports, bottom 40° A and B
SAE J518 1 1/4" 6000 psi

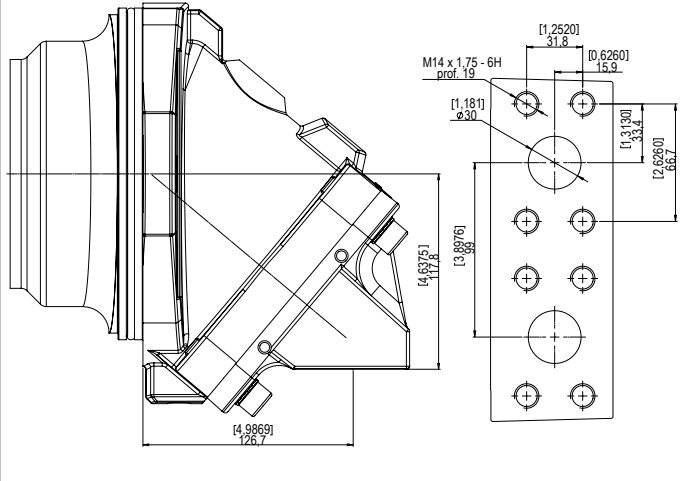

M0 Rear flanges
SAE 1 1/4" 6000 psi

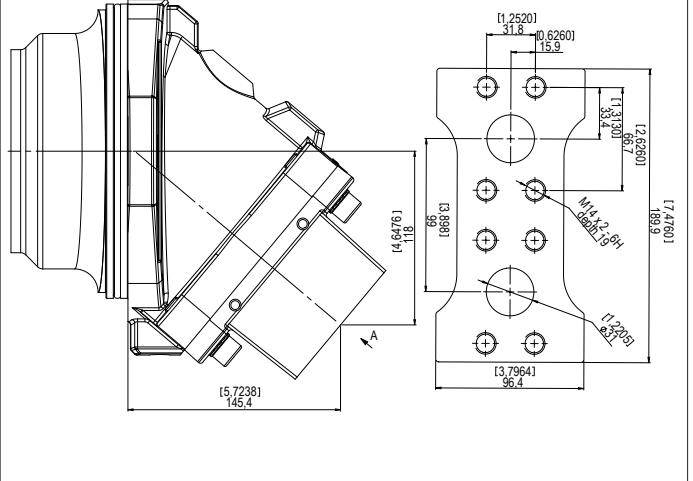

N0 or N1 Side flanges
SAE 1 1/4" 6000 psi

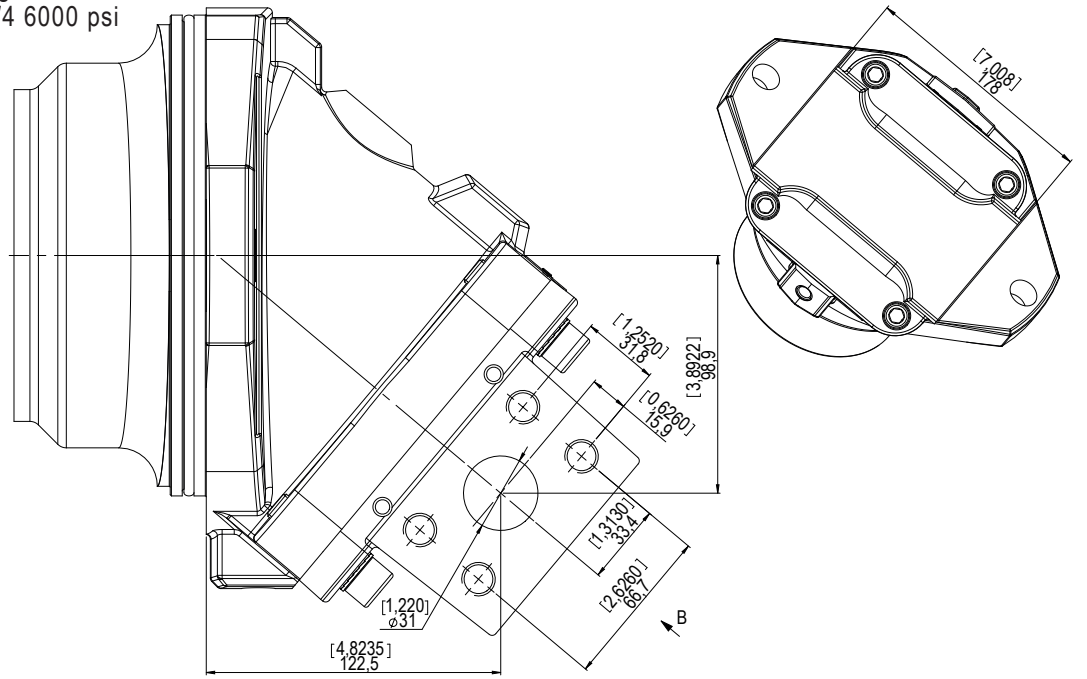

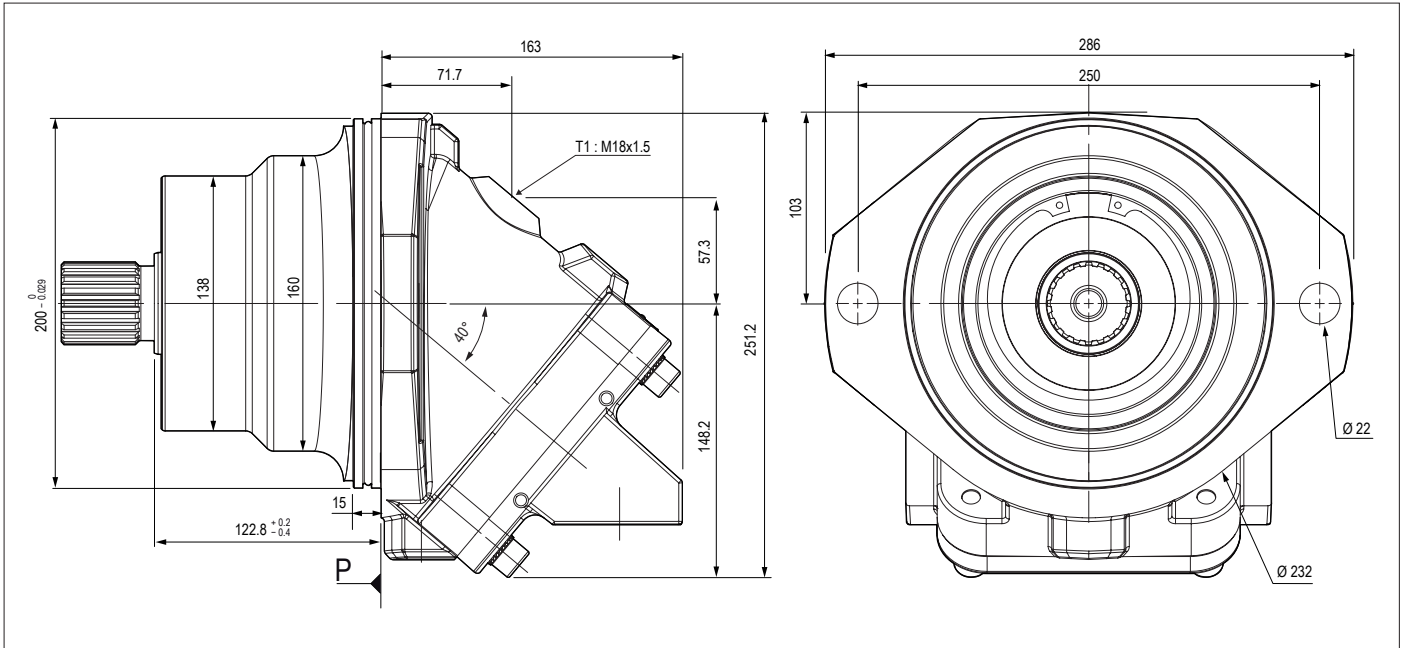

► Shaft end

W1 Splined shaft DIN 5480
W 45 x 2 x 30 x 21 x 9 g

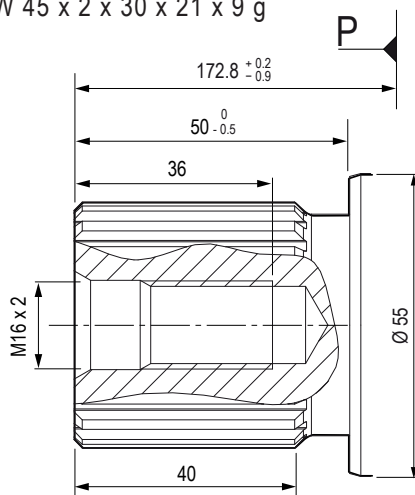

W2 Splined shaft DIN 5480
W 40 x 2 x 30 x 18 x 9 g

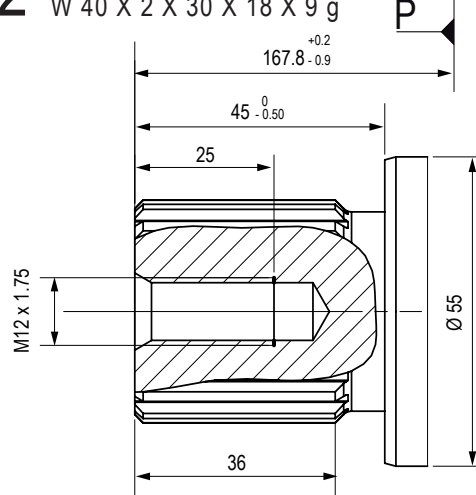

D1 Keyed shaft Ø45 DIN 6885
A 14 x 9 x 63

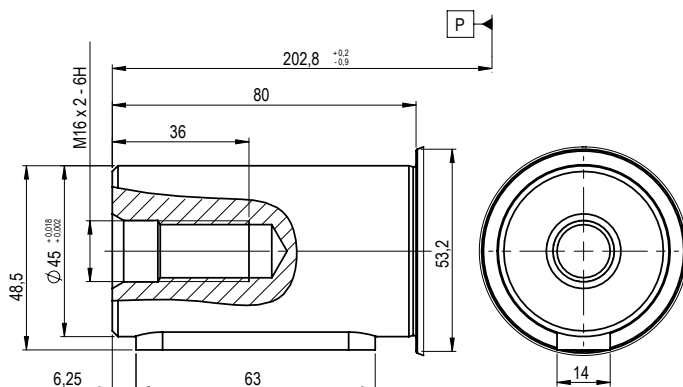

► Inlet ports

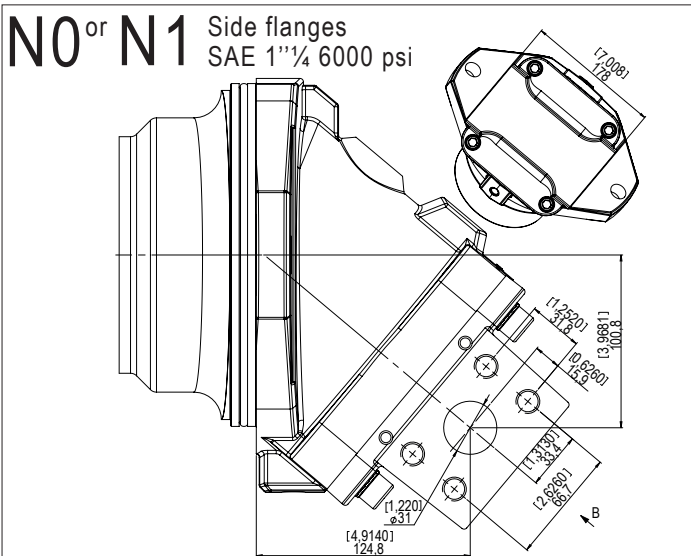
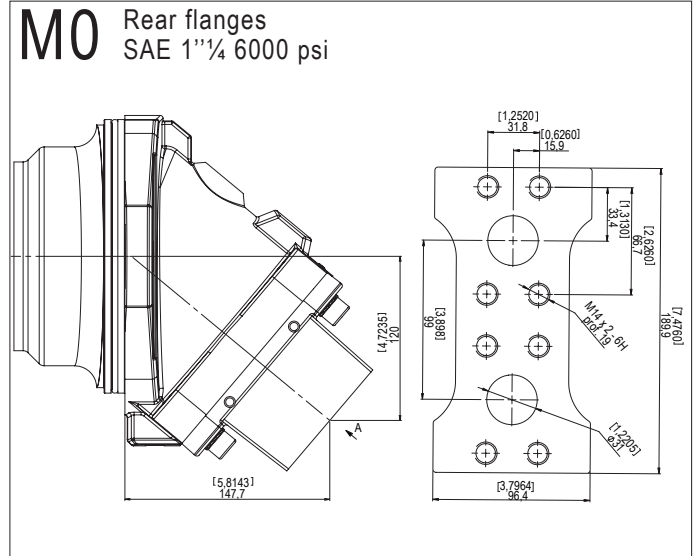
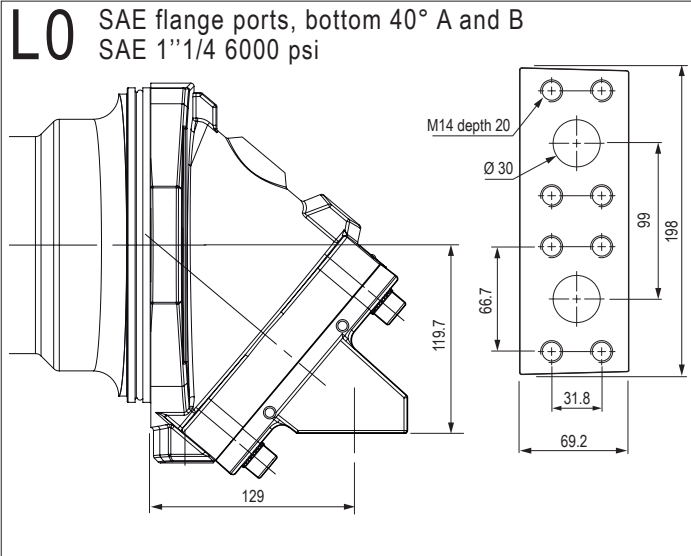

Dimensions are given only as an indication. Measurements in mm and [inches].

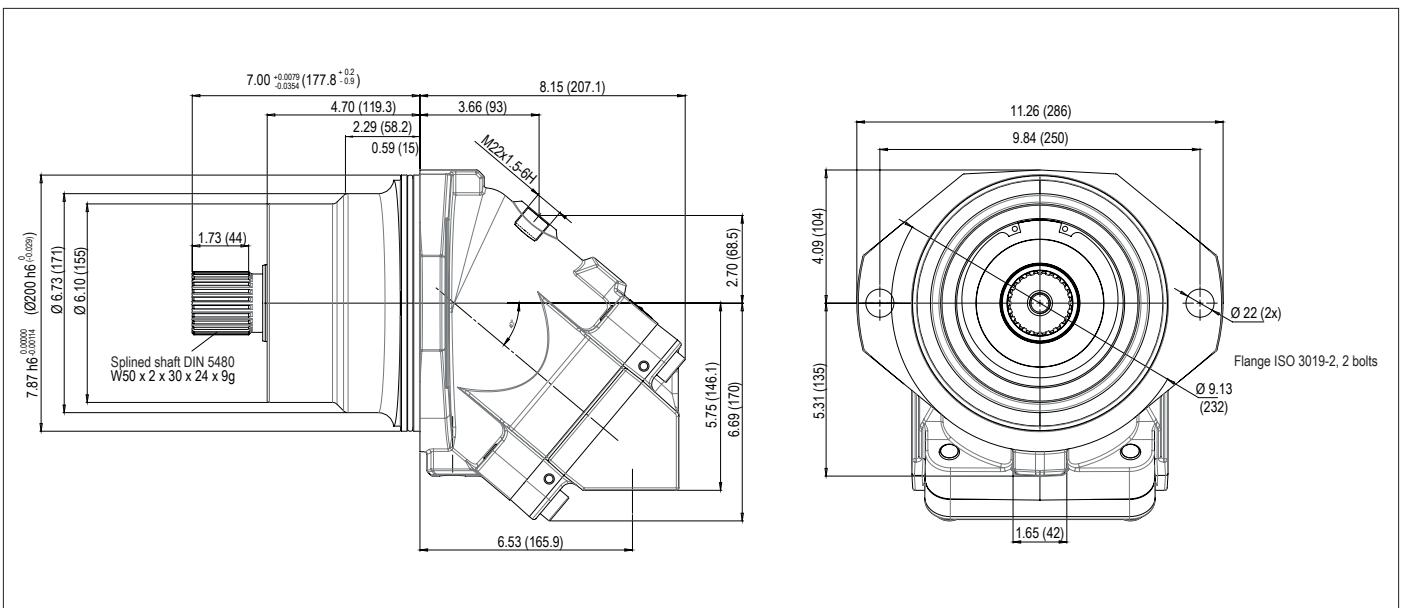
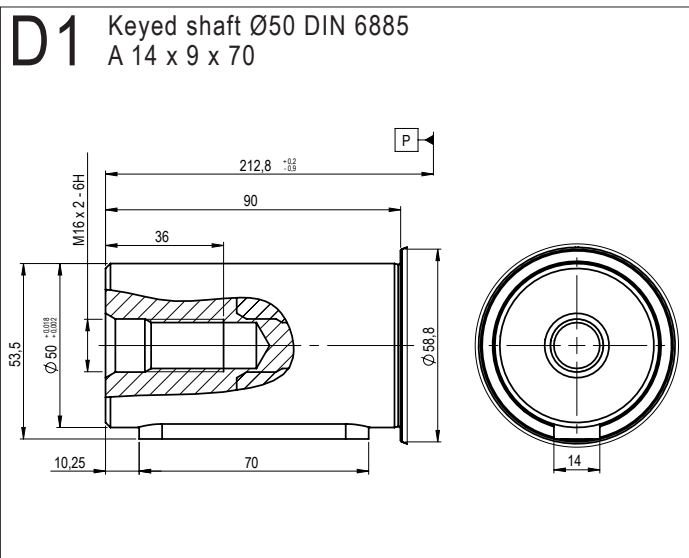
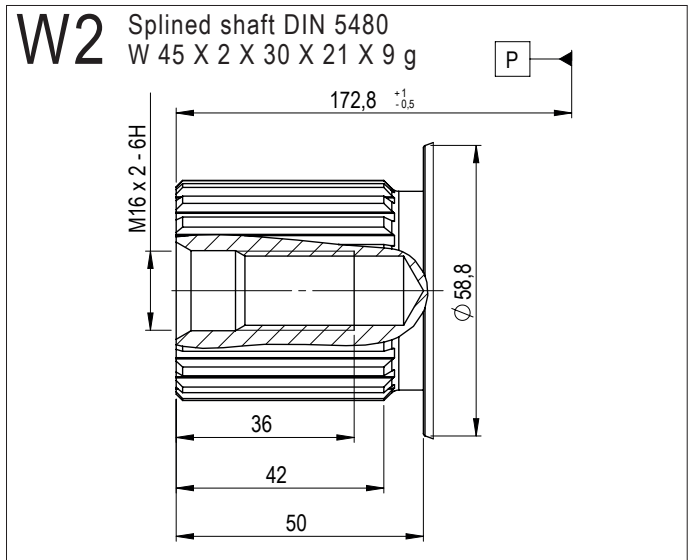
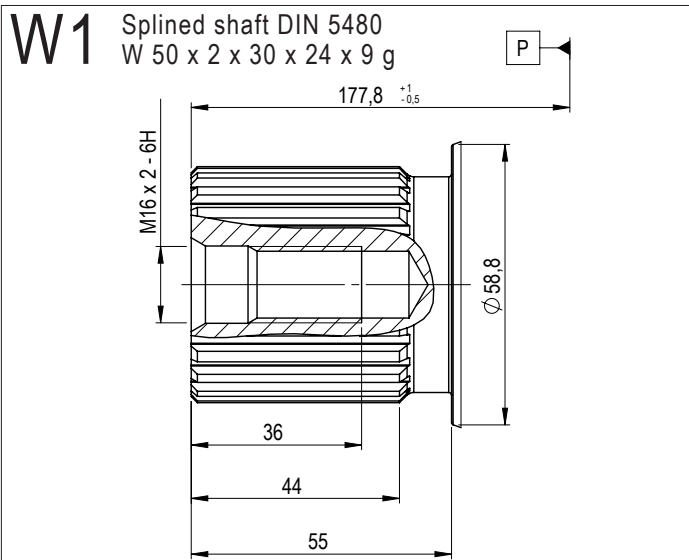
**▶ Shaft end**

► Inlet ports

L0 SAE flange ports, bottom 40° A and B
SAE 1 1/4 6000 psi

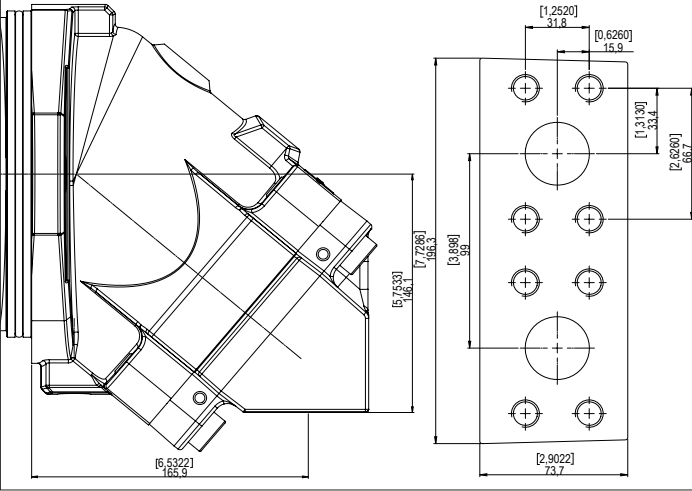

M0 Rear flanges
SAE 1 1/4 6000 psi

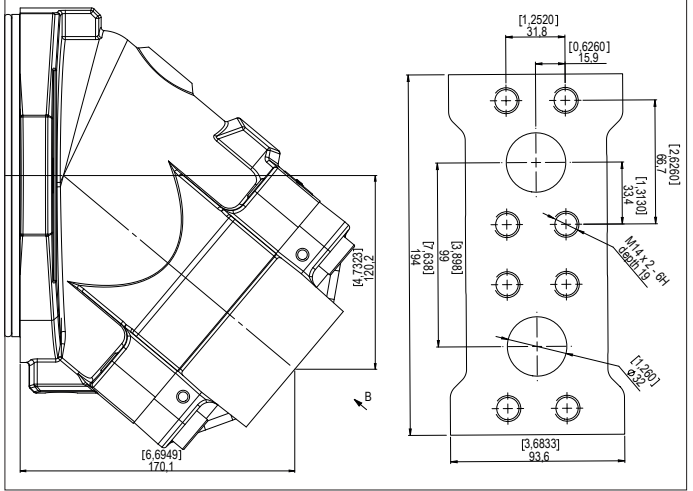

N0 or N1 Side flanges
SAE 1 1/4 6000 psi

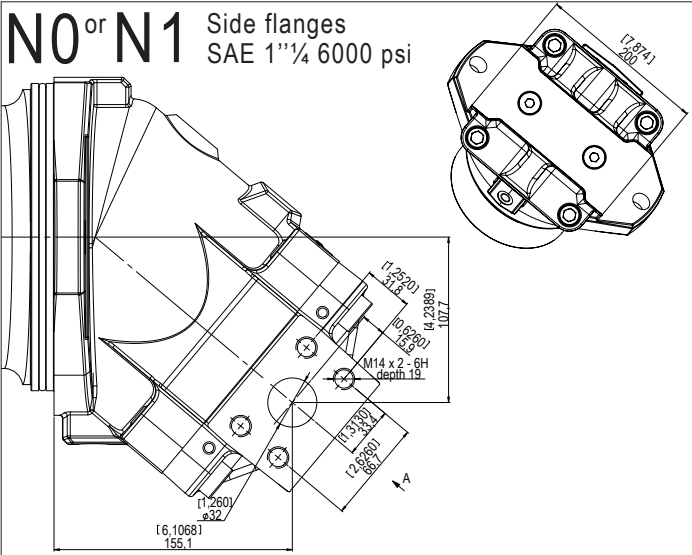

Dimensions are given only as an indication. Measurements in mm and [inches].