

variable displacement pumps

# DELTA SAE

Serie

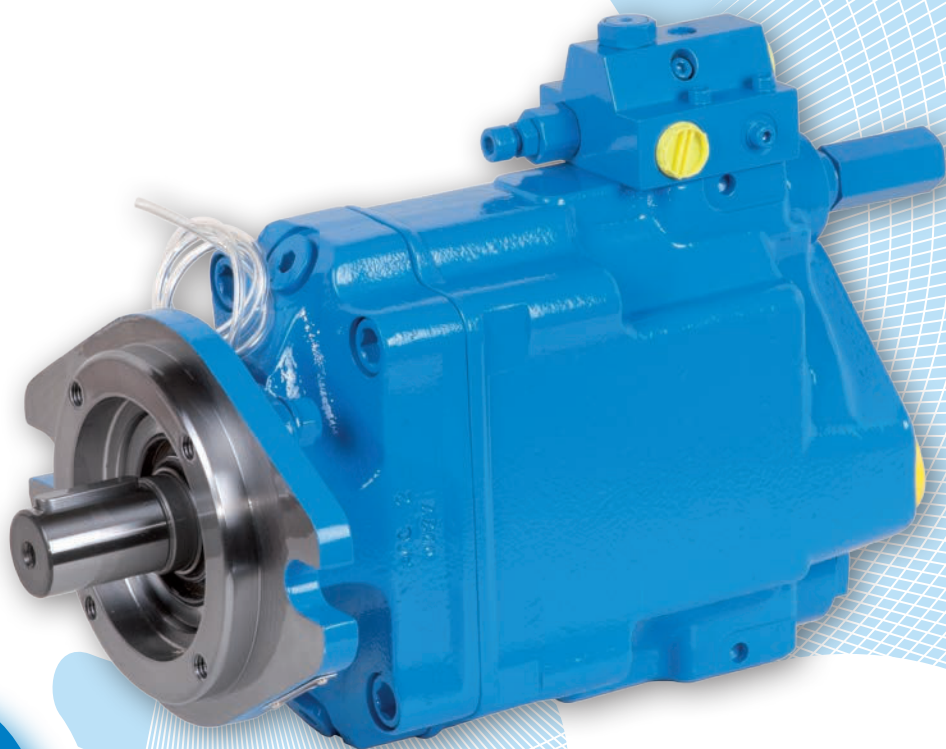

 **HYDRO  
LEDUC**

*make it simple*

# Contents DELTA series pumps

■ Range and characteristics .....	1
■ Dimensions .....	2
■ Performance .....	5
■ Control devices .....	4 to 8
<b>Under development</b>	
■ Delta pump with constant torque LS control .....	9
■ Fittings .....	10
■ Shaft sealing .....	11
■ Installation and start-up recommendations .....	12
■ The complete LEDUC product range .....	13

Designed for open loop hydraulic circuits, the DELTA range of variable displacement pumps allow optimized performance for a given application.

The flow supplied by the pump is automatically regulated according to the hydraulic load. This guarantees:

- minimized energy consumption,
- minimized heating of fluid,
- reduced noise levels.

Built on 40 years know-how and experience, the DELTA pumps are the result of advanced development work and analysis on the needs of the hydraulic end-user.

The DELTA pumps satisfy the needs of the more demanding users.

The pump provides:

- long service life,
- no pressure pulsations,
- low noise level,
- exceptional power to weight ratio,
- high outlet pressure,
- easy start-up thanks to good self-priming and suction characteristics.

Displacements in production include 40, 60, 75 and 92 cc/rev.

Depending on the application, displacements of 120 and 130 cc/rev can be delivered on request.

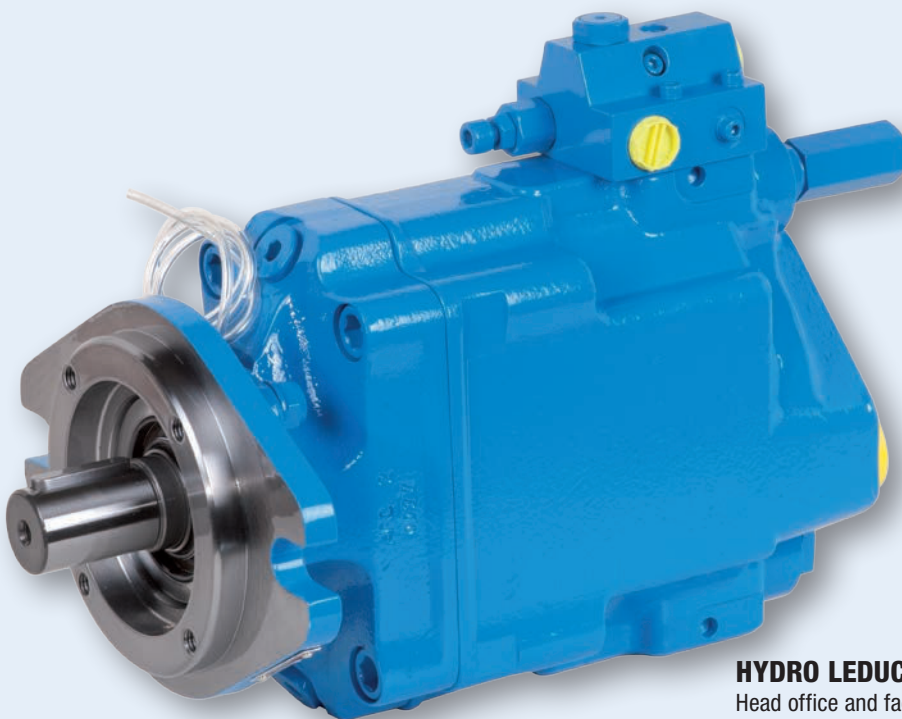

**HYDRO  
LEDUC**

**HYDRO LEDUC**  
Head office and factory  
BP 9  
F-54122 AZERAILLES  
(FRANCE)  
Tél. +33 (0)3 83 76 77 40  
Fax +33 (0)3 83 75 21 58

# Range and characteristics DELTA series pumps

Pump	Reference	Direction of rotation	Max displacement (cc)	Maximum operating pressure (bar)	Maximum peak pressure (intermittent 5%)	Max operating pressure at flow cancellation (bar)	Torque at 300 bar (Nm)	Max speed (rpm)	Weight (kg)
DELTA 40	0512370	SH	40	400	420	440	220	3000	29
	0512375	SIH							
DELTA 60	0513140	SH	60	400	420	440	295	2600	29
	0513145	SIH							
DELTA 75	0512340	SH	75	400	420	440	410	2000	29
	0512345	SIH							
DELTA 92	0512350	SH	92	380	400	420	483	1900	29
	0212355	SIH							

These are the references of the pump alone. When ordering, also specify the reference of the required control device. See page 4.

## Setting pump maximum displacement

The DELTA pumps from 40cc to 92cc are made as standard to be able to use the setting screw. The pump displacement can thus be adjusted to exactly what is needed.

### How to use the setting screw

Unscrew **1** completely, loosen **3** and screw **2** to the required displacement. See figure above.

For DELTA 92 to 40: 1 turn of the screw changes the displacement by 8 cc.

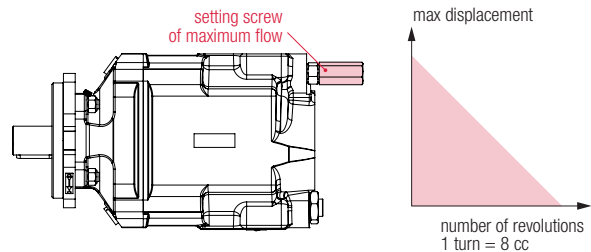

DELTA 40: can be set from 40 to 25 cc/rev  
 DELTA 60: can be set from 60 to 35 cc/rev  
 DELTA 75: can be set from 75 to 55 cc/rev  
 DELTA 92: can be set from 92 to 70 cc/rev

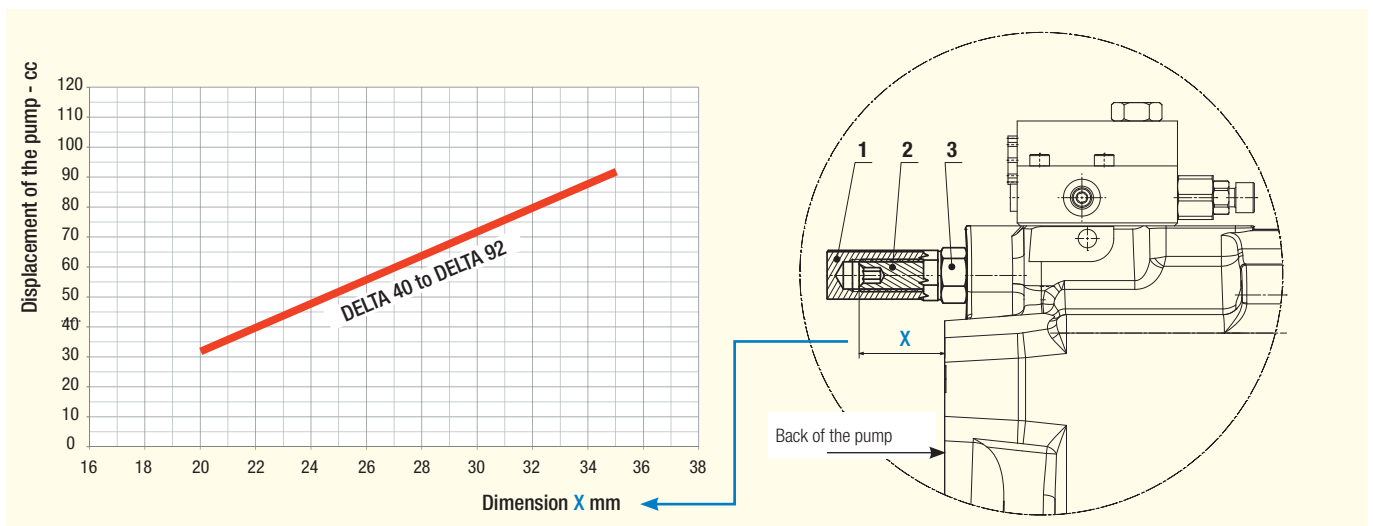

# Dimensions DELTA series pumps

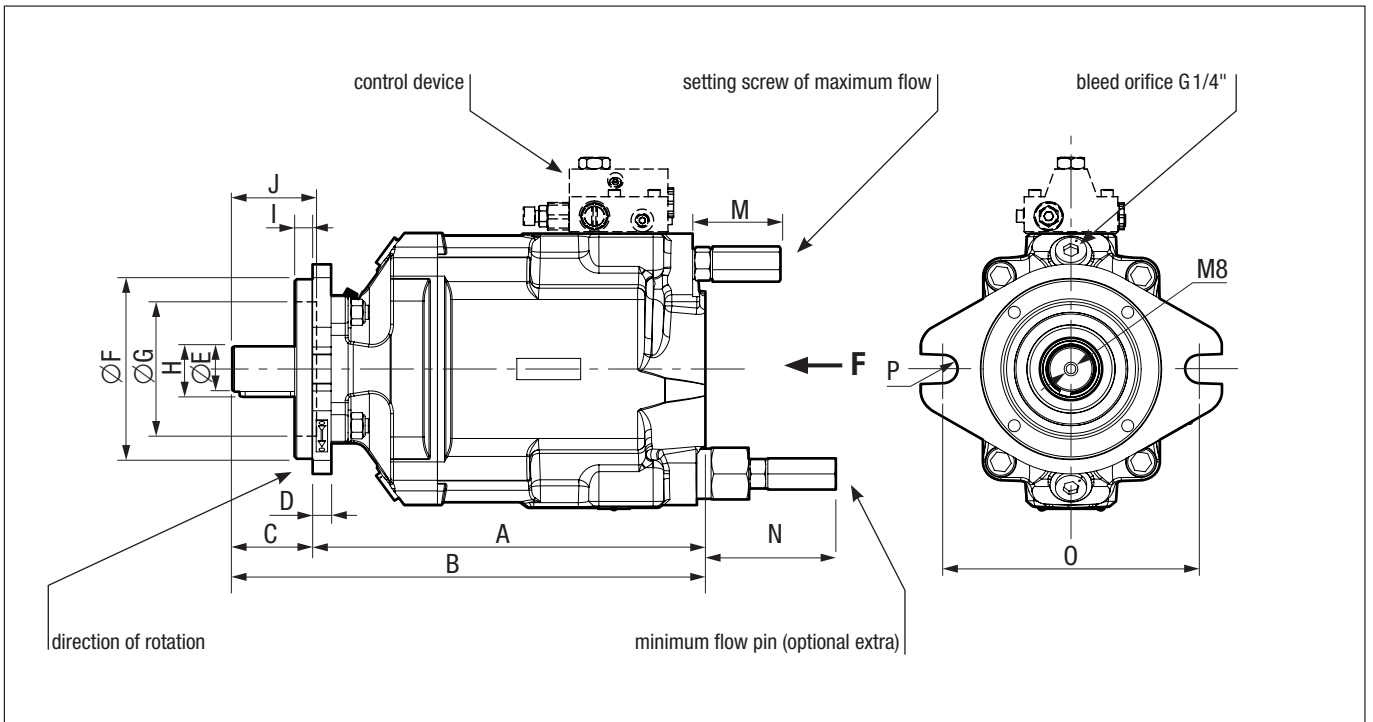

Pump	Dimensions (mm)													
	A	B	C	D	∅E	∅F	∅G	H	I	J	M	N	O	P
DELTA 40	282	329	47	10	25.4 h9	101.6 h8	80	28.1 JS13 (bey width 6.38h9)	9.5	46	62	97	146	R8
DELTA 60 to 92	282	339.1	57.1	13	31.75 h8	127 h7	95	35.2 JS13 (bey width 8e9)	12.7	58.4	62	97	181	R10

For other shafts, please contact our Technical Department.

## DELTA connections

(other port styles available)

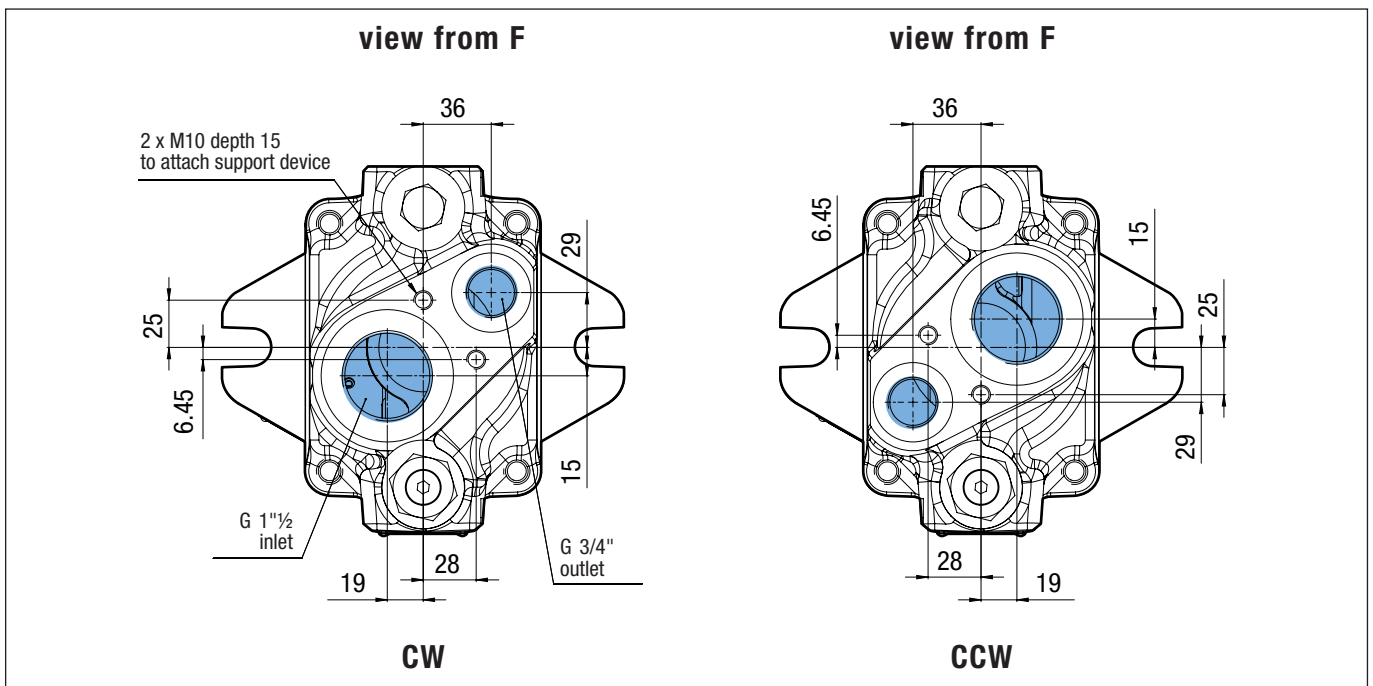

Dimensions are given only as an indication.

# Performances DELTA series pumps

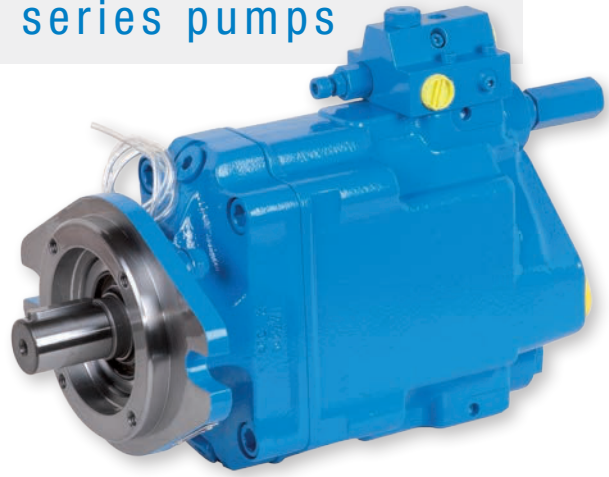

## Flow

Flow as a function of speed and displacement of the pump.

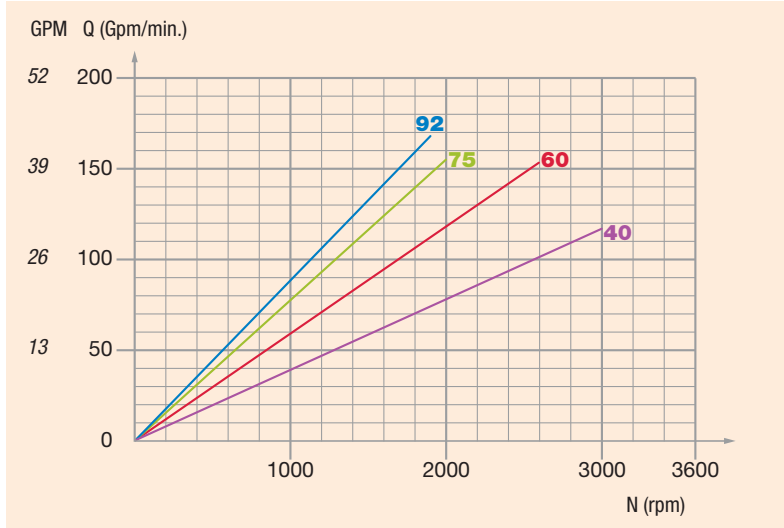

## Required torque at maximum displacement

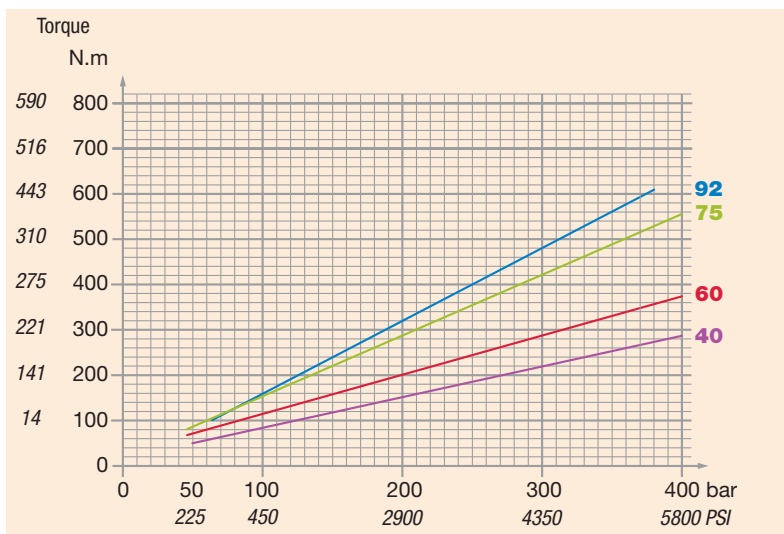

## Volumetric efficiency

Viscosity 100 cSt, inlet at air pressure.

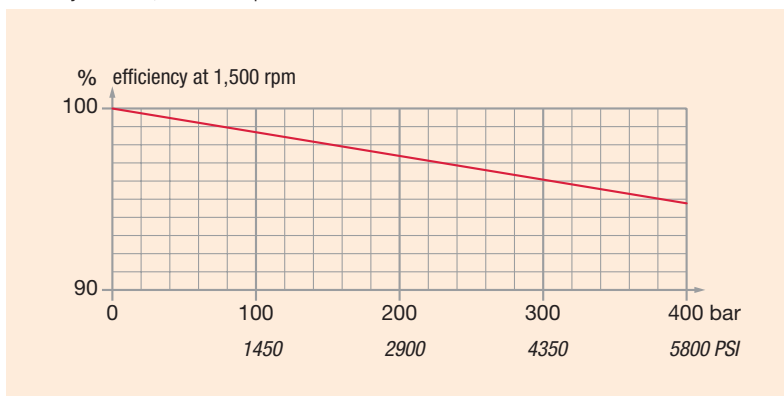

## Calculating power as a function of torque

$$C = \frac{P \text{ (kW)}}{\omega} \times 1000 = N.m$$

$$\omega = \frac{\pi N}{30}$$

$$P \text{ (kW)} = \frac{\Delta P \times Q}{600}$$

(theoretical hydraulic power) where:

**N** = speed in rpm

$\Delta P$  = working pressure in bar

**Q** = flow in l/minute

## Ideal installation: tank above the pump

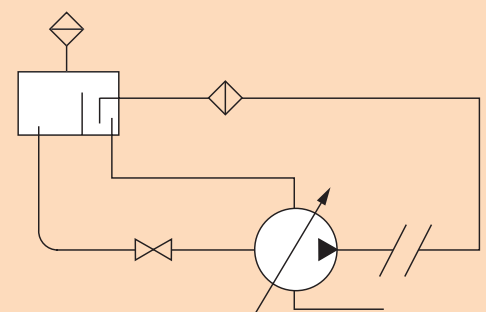

These graphs are the results of tests carried out by the HYDRO LEDUC Research Laboratory, on a specific test bench, with ISO 46 fluid at 25°C (100 cSt), a 50 mm diameter supply line 1.5 m long, and a tank with oil level at the same height as the pump.

# Control devices DELTA series pumps

Reference		Designation	Weight (kg)
PC	0519180	Constant Pressure	1.10
PCD	0519070	remote control constant pressure	1.10
PCDM	0519340 + adjustable displacement screw 0512602	constant pressure with minimum flow control	2.50
LS	P001992	flow-pressure regulation	1.10
LSD	0519080	remote control flow-pressure regulation	1.10
KPF	0520693	plate + fixation screw	0.30

## PC - Constant Pressure

The pressure control maintains constant pressure in the hydraulic system. As soon as pressure reaches the level set on the control, the flow of the pump automatically regulates itself according to what the application requires. This minimizes system heat and energy for those applications requiring pressure to be held constant.

Examples:  
 - hydraulic press,  
 - compression mold,  
 - manufacturing of composites...

**Important note!**  
 otherwise specified by customer:  
**PC will be set at 100 bar**

4

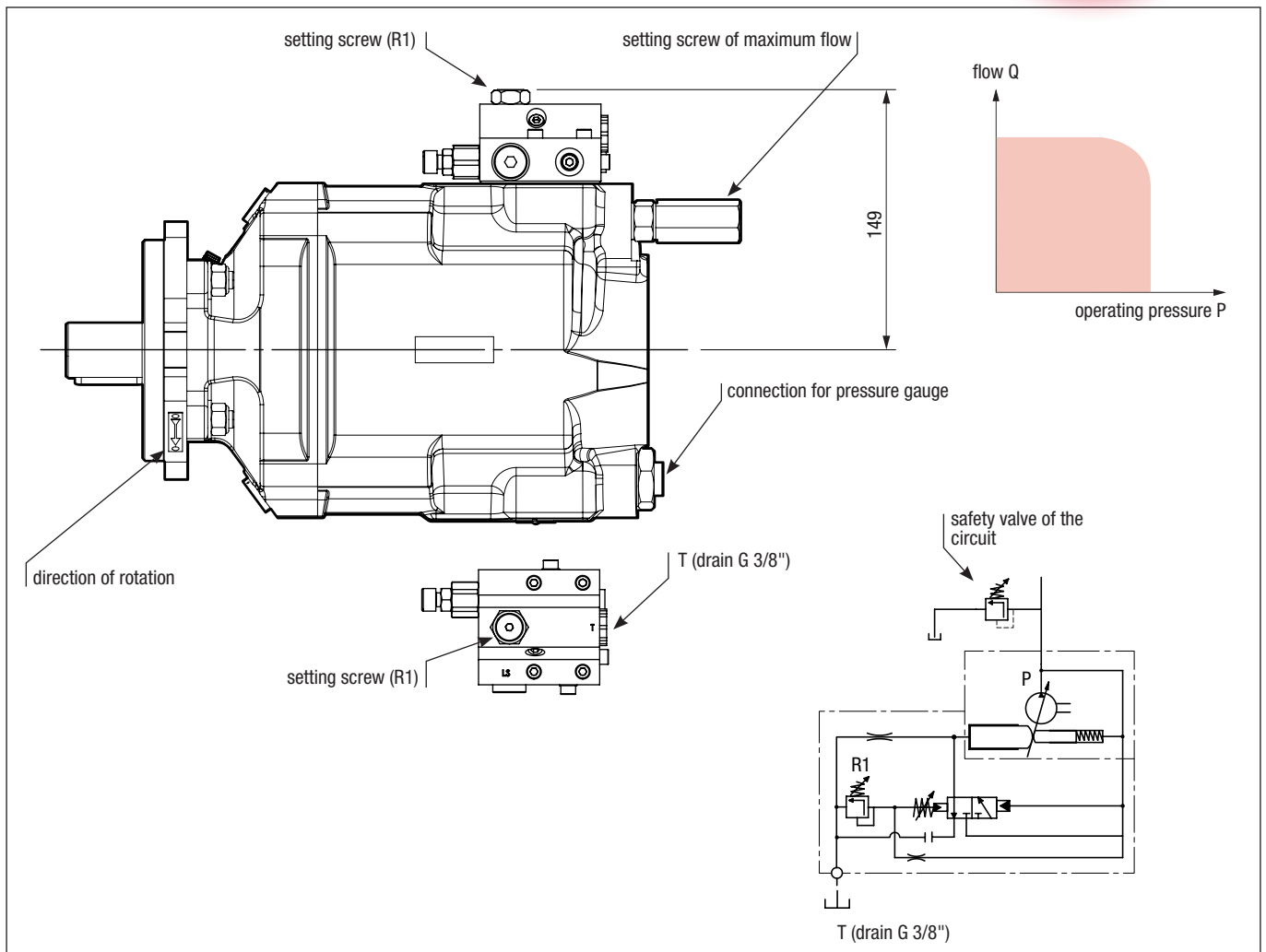

## ■ PCD - Remote control constant pressure

This allows to control the pressure setting according to the requirements of the different devices within the circuit.

Examples:

- control of a cylinder under maximum pressure of 300 bar,
- control of a hydraulic motor at 200 bar.

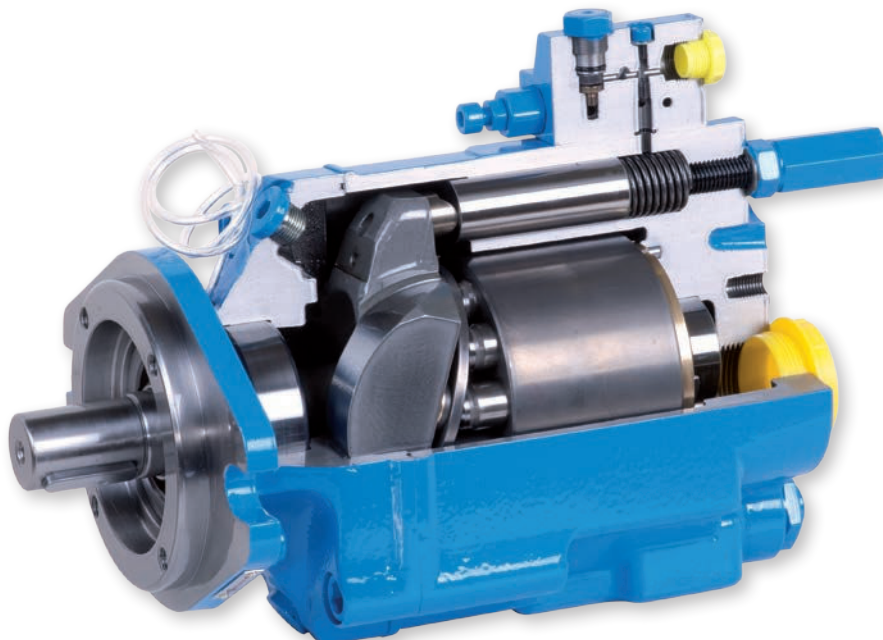
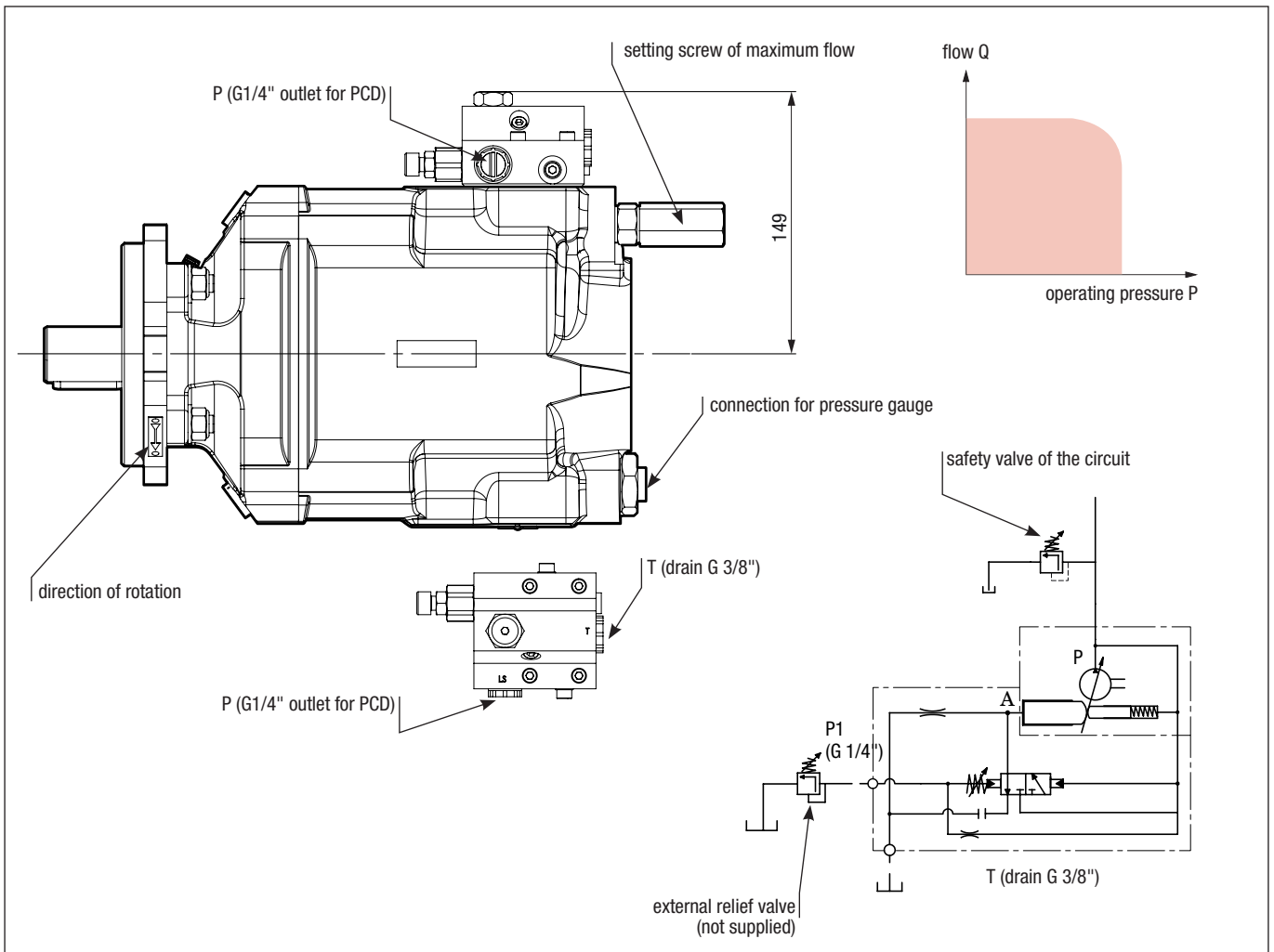

## PCDM - constant pressure with minimum flow control

**Constant pressure with minimum flow control: PCDM** (can also be remote PCD-DM).

This is used in every case where the reduction of the main flow must still allow the flow of a separate device.

### Capacity to control minimum displacement

The DELTA pumps are designed to regulate flow from maximum flow to flow cancellation mode. However, some applications require a minimum outlet flow to be maintained, regardless of how flow is controlled from maximum to minimum.

The PCDM control device must always be used with a pressure relief valve (not supplied) to cancel pump flow when maximum pressure is reached.

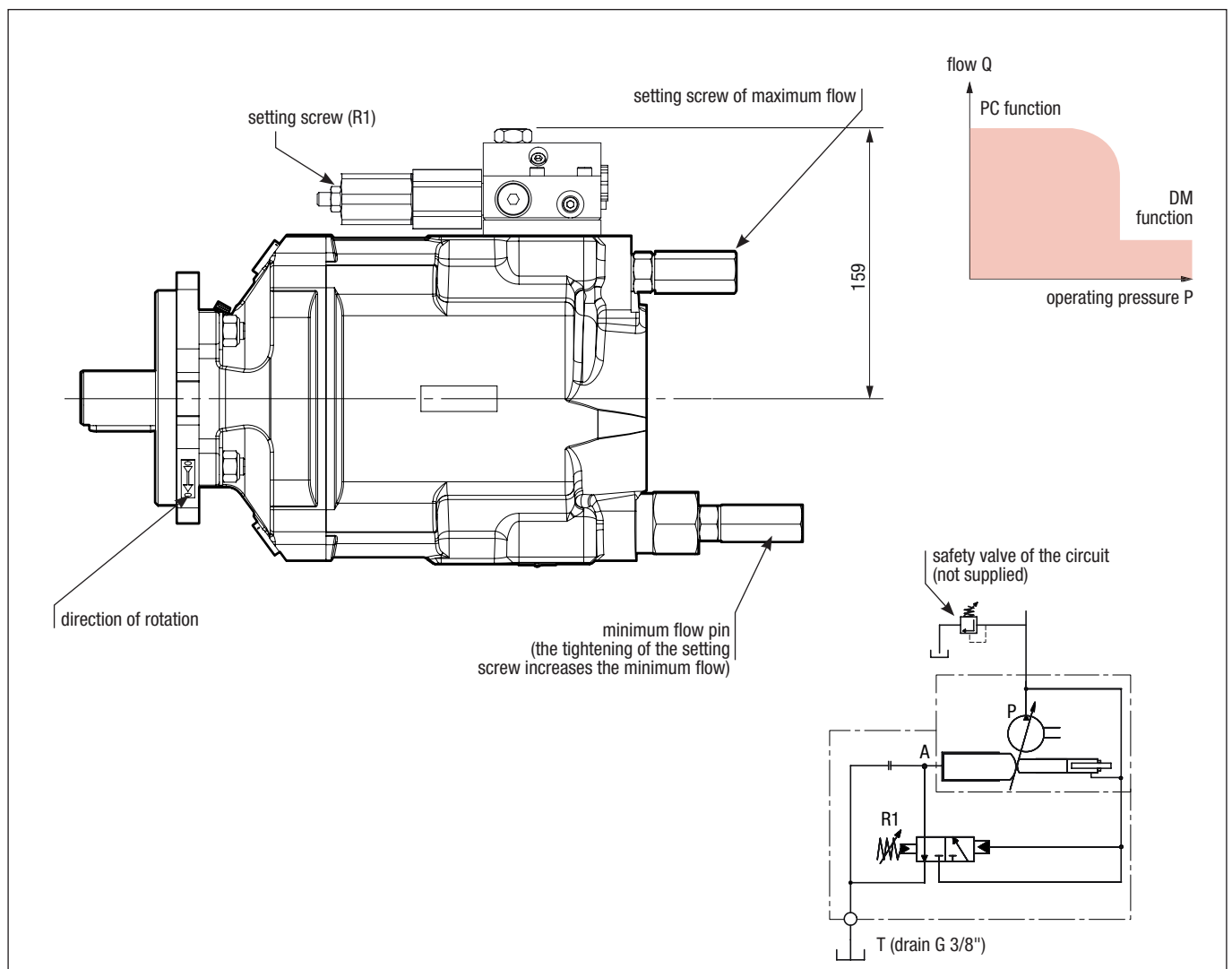
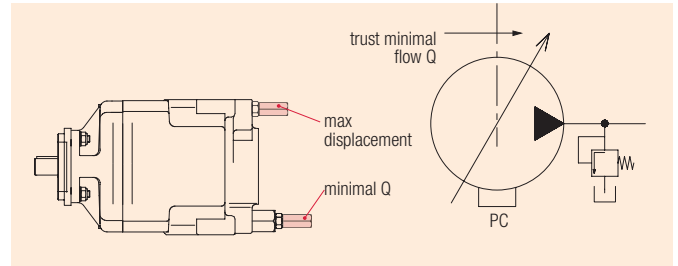



**Important note !**  
 otherwise specified by customer:  
 PC will be set at 100 bar  
 stand-by at 30 bar

## ■ LS - Flow-pressure control

### ■ Contrôle Q et P (LS : Load-Sensing)

This control device (LS) enables the flow and the maximum output pressure of the pump to be controlled continuously.

From this, it is easy to imagine all possible combinations:

- large flow and small pressure,
- high pressure and small flow.

This type of control can be fitted with remote control to control pressure and flow.

### ■ Principle of flow-pressure control

The flow of the pump **Q** through the application **E** must ensure a constant  $\Delta P$  set at 20 to 30 bar.

**S**: surface of the cross section of oil passage

This  $\Delta P$  is proportional to:

$$\frac{Q}{S} \text{ soit } \Delta P = f\left(\frac{Q}{S}\right)$$

Each time the  $\Delta P$  varies due to a change at **E**, the pump will vary its flow **Q** to suit and to ensure:

$\Delta P = \text{constant}$ .

**E** can be:

- a flow control,
- a proportional valve,
- a simple restriction device.

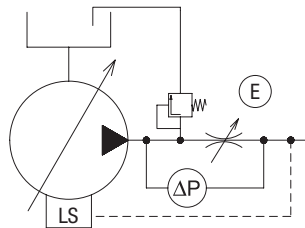

### ■ Principle of pressure control

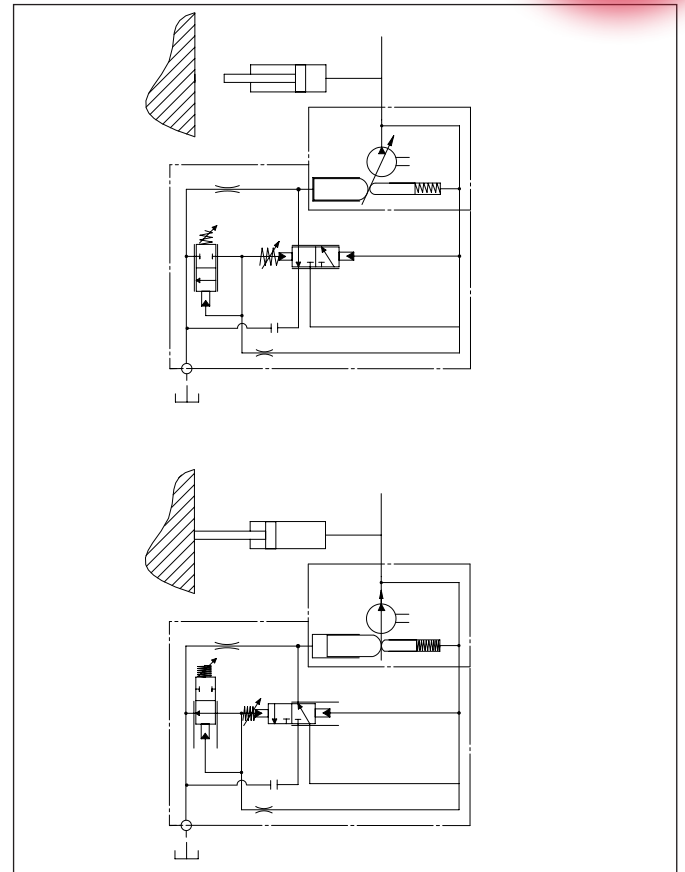

## LSD - Remote control flow-pressure regulation

### Flow-pressure regulation

This control device means flow can be controlled continuously with remote control pressure compensation (LSD).

The pressure is controlled via an external pressure relief valve (not supplied).

### Principle of flow-pressure control

The flow of the pump **Q** through the application **E** must ensure a constant  $\Delta P$  set at 20 to 30 bar.

**S**: surface of the cross section of oil passage

This  $\Delta P$  is proportional to:

$$\frac{Q}{S} \text{ soit } \Delta P = f\left(\frac{Q}{S}\right)$$

Each time the  $\Delta P$  varies due to a change at **E**, the pump will vary its flow **Q** to suit and to ensure:

$\Delta P = \text{constant}$ .

**E** can be:

- a flow control,
- a proportional valve,
- a simple restriction device.

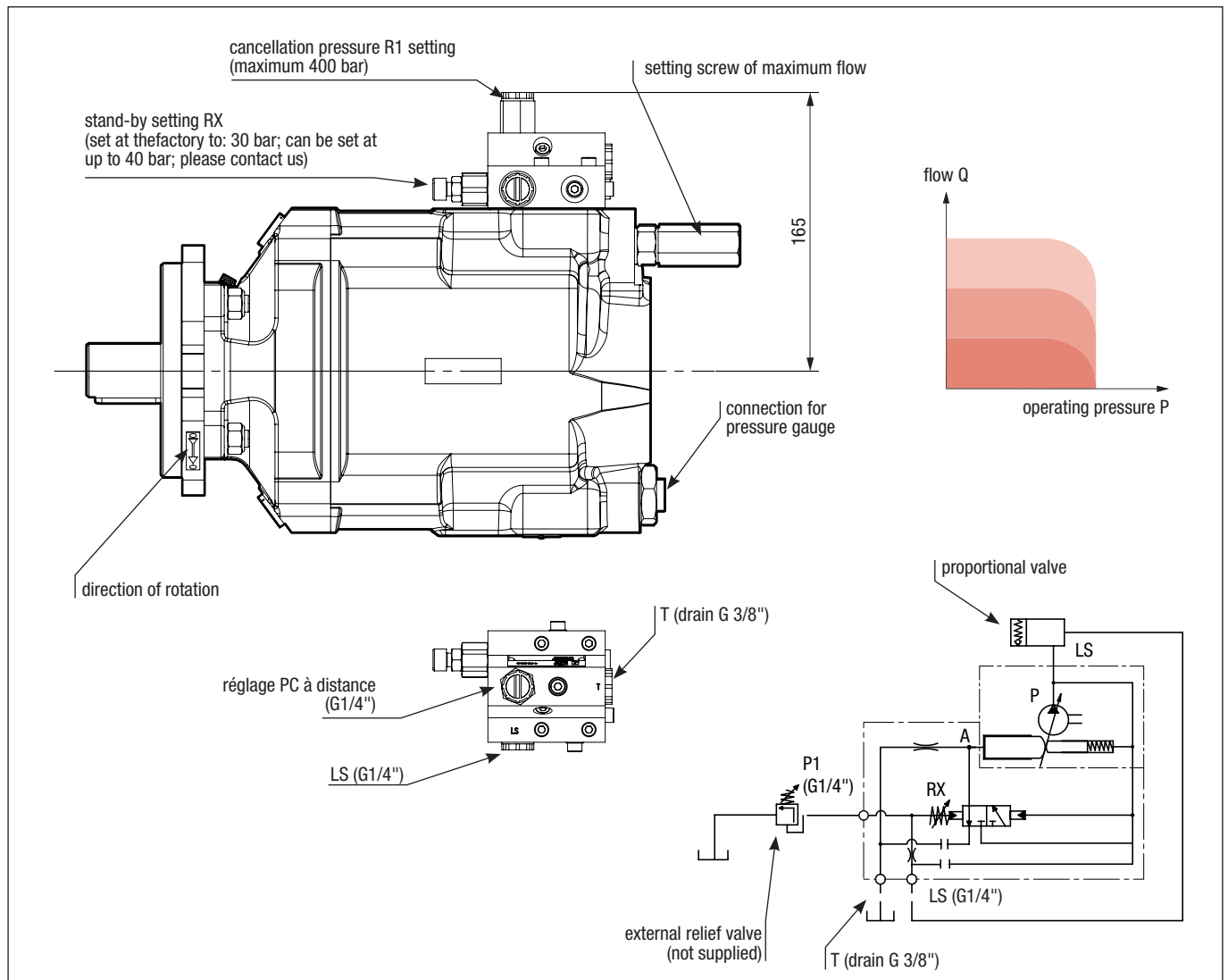

## DELTA pump with constant torque LS control

Under development

### Description

This constant torque control for the DELTA pumps ensures that the power installed in the circuit cannot be exceeded, whilst still allowing control of flow and of maximum circuit pressure. The constant torque LS control is available for DELTA pumps of 40, 60, 75, 92 and 92cc.

The dimensions of the constant torque LS control are the same as for the standard LS valve.

**Warning: this control device can only be associated with a DELTA pump provided with a constant torque LS control.**

Pump		Direction of rotation	Max displacement (cc)	Maximum operating pressure (bar)	Maximum peak pressure (intermittent 5%)	Max operating pressure t flow cancellation (bar)	Torque at 300 bar (Nm)	Max speed (rpm)	Weight (kg)
DELTA 40	0521300	CW	40	400	420	440	220	3000	29
	0521305	CCW							
DELTA 60	0521310	CW	60	400	420	440	295	2600	29
	0521315	CCW							
DELTA 75	0521320	CW	75	400	420	440	410	2000	29
	0521325	CCW							
DELTA 92	0521330	CW	92	380	400	420	483	1900	29
	0521335	CCW							

The constant torque control on the TXV pump shaft is controlled by the Load Sensing device (flow and pressure regulation).

### Principle

The constant torque control means “pressure x flow = constant” is permanently achieved. Precision is 5% to 10% around the theoretical curve. The setting is done at the factory. For each order, please stipulate the pump displacement, standby pressure, and the constant torque level required. The constant torque control is always complete with constant pressure (PC) control and flow control.

The constant torque LS control device must always be used with a pressure relief valve (not supplied) to cancel pump flow when maximum pressure is reached.

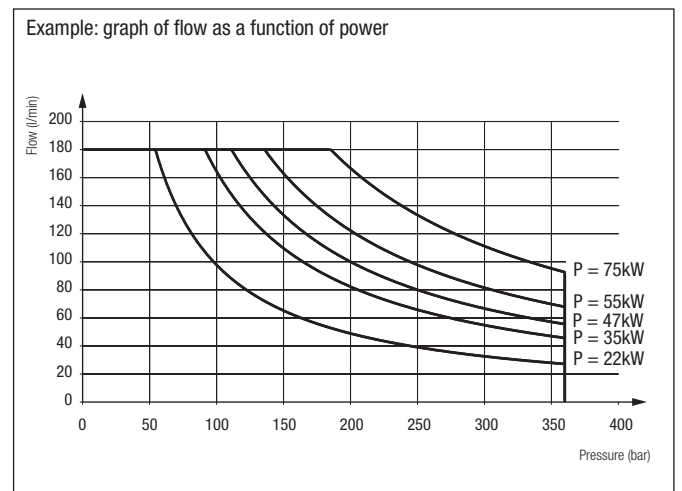
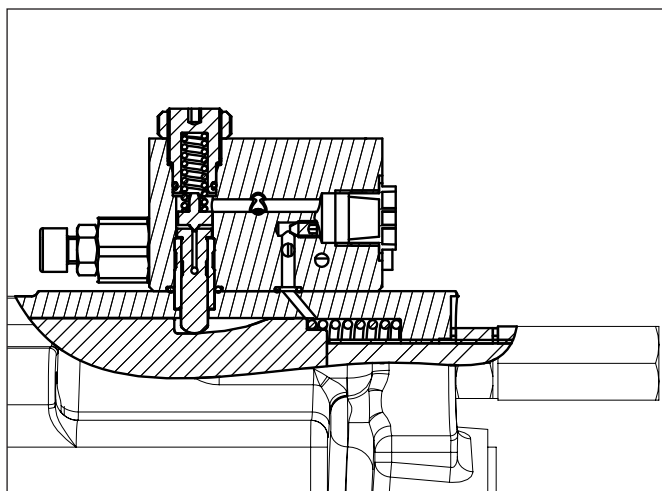
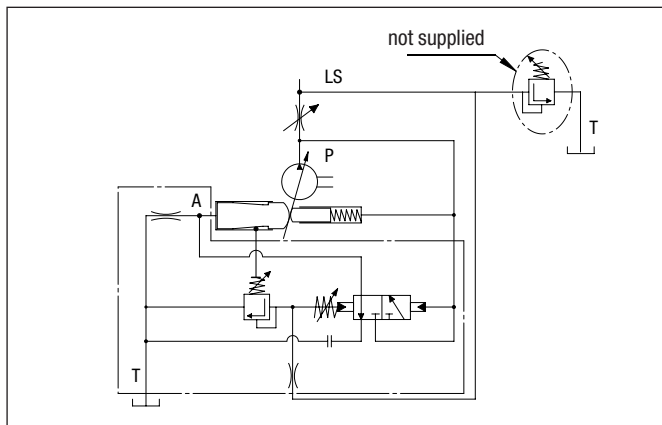

## Inlet fittings

To be used on the inlet orifice of the DELTA pumps.

### 90° elbow fittings, swivel

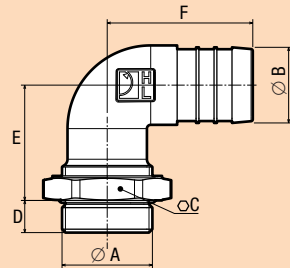

Reference	A	Ø B	C	D	E	F
240131	G 1"½	40	60	17	61	77
240133	G 1"½	50	60	17	65	82

### Straight fittings

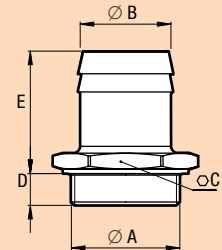

Reference	A	Ø B	C	D	E
051523	G 1"½	40	56	14	54
240067	G 1"½	50	52	14	66
240066	G 1"½	60	64	14	69
240186	G 1"½	63,5	64	14	69
240201	G 1"½	76.2	80	14	89

## Force on pump shaft

**Fr** : acceptable max radial force = 3000 N,

**Fa** : acceptable axial force = 1600 N.

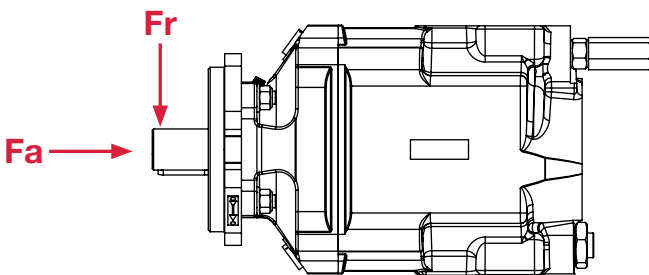

## Optimization of the transmission of power to the shaft of the pump

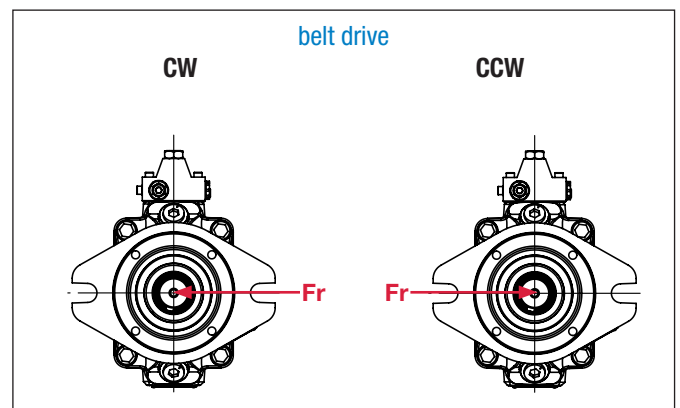
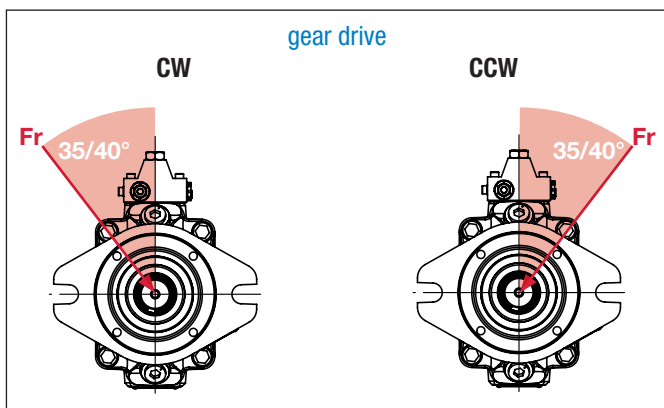

**LEDUC pumps destined for truck hydraulics are all fitted with reinforced sealing comprising:**

- two radial seals: an external seal adapted to the needs of PTOs and gear-boxes; and an internal seal adapted to the needs of hydraulic performance;
- an original protection of the pump shaft seals. This is a flexible transparent tube which avoids any entry of contaminants between the two seals, and to assure air vent of the space between the two seals.



 **Recommendations for attaching the protective tube:**

- make a siphon with the tube so as to avoid any introduction of:
  - dirt from road;
  - water or damp from high pressure washing of vehicle.
- put the end of the tube downwards, or in a place sheltered from any projections;
- fix the tube in place using a collar/clip.

 **Avoid:**

- attaching the tube to any parts which may move, this could lead to it being damaged or torn off;
- any pinching or folds in the tube when fixing it in place;
- any obturation of the end of the tube.

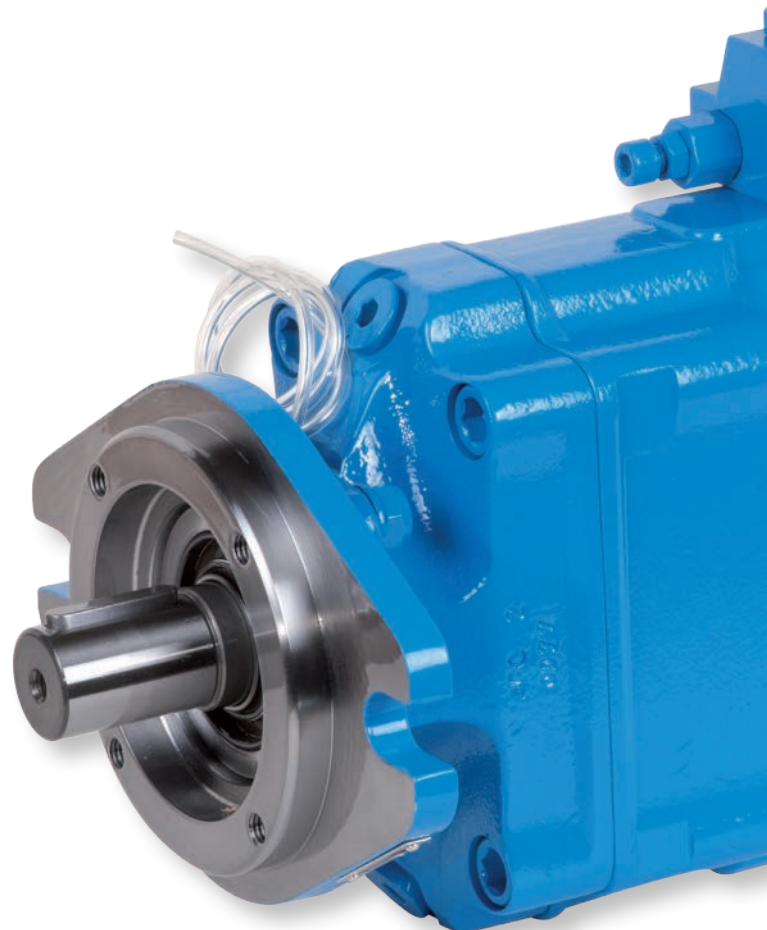

*Make sure your pump lives a long happy life !*

## ■ The tank:

Generally, hydraulic pumps much prefer a tank **above** the pump. LEDUC pumps can also operate with oil level beneath the pump, for further information on such installations, please contact our Technical Department. Correct inlet conditions are between 0.8 to 2 bar absolute pressure. The tank should preferably have a separation between inlet side and return. This avoids fluid emulsion and the introduction of air into the hydraulic circuit. Ensure also that the suction is not from the very bottom of the tank, so as to protect the pump from any deposits (particles).

## ■ Hosing:

Should be dimensioned to ensure flow between 0.5 and 0.8 m/second. Choose as direct a supply line as possible, avoiding sharp bends.

## ■ Filtration:

HYDRO LEDUC recommends using a very clean tank, filtered during filling and with filter on air vent.

The pump supply line must be cleaned (decontaminated) and the return line should be filtered as follows:

### For relatively simple circuits

Use a 20 micron filter on pump return line.

### For more complex circuits

Ideal solution: high pressure filter between the pump and the hydraulic circuit, 10 to 20 micron filter, clogging indicator.

## ■ The fluid

Use a mineral hydraulic oil with viscosity between 10 and 400 cSt. It is in this viscosity range that the pumps keep their volumetric characteristics.

If you wish to use other fluids, please consult our Technical Department. Maximum temperature of fluid in the pump should not exceed 100°C.

## ■ Drive and assembly recommendations

For PTO mount applications, be careful to respect the tightening recommendations in terms of pump onto PTO and PTO onto vehicle gearbox. DELTA pumps are not designed to withstand any axial load on the pump shaft. Check your installation conforms to this requirement.

## ■ Preparation of the pump

Before start-up, the pumps should preferably be filled with oil.

## ■ Start-up

- open the supply valve if there is one;
- check the valve is in "back to tank" position;
- partially unscrew the output fitting;
- start up at low speed, or by successive starts/stops;
- retighten the output connector as soon as air bubbles have disappeared;
- let the pump run for one to two minutes, and check that the flow is well established;
- check the pump is running correctly, with no vibrations nor abnormal noise;
- after several hours of operation, check the tightening torque of the pump fixture to PTO.

## ■ Maintenance

Some regular checks are necessary, namely:

- tightening of pump to PTO;
- cleanliness of fluid;
- state of filter.



If you notice traces of oil in the plastic tube, it is essential to check the sealing between PTO and pump.

Each LEDUC pump is supplied with a leaflet with installation and start-up recommendations.

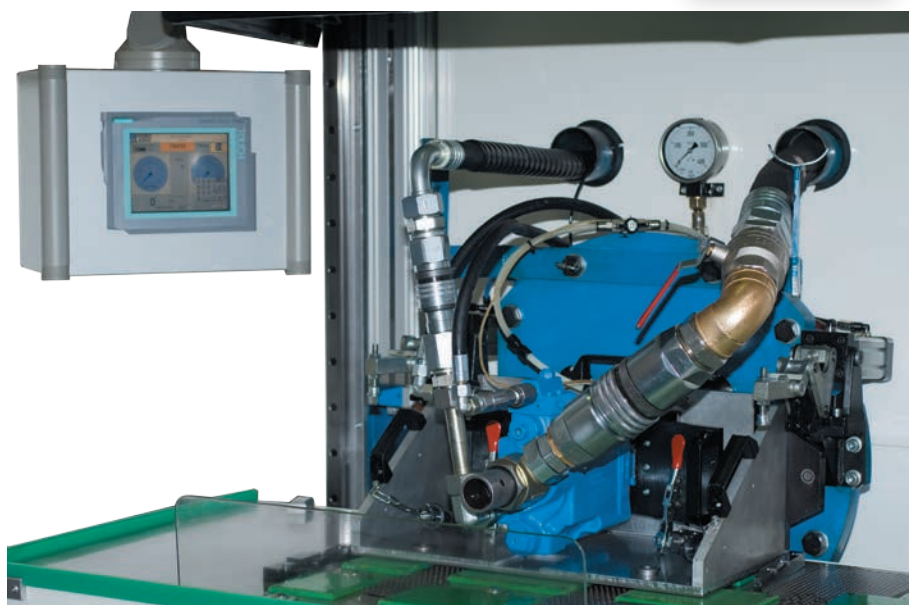

## other product lines

### hydraulic motors

Fixed displacement bent-axis piston motors. Models from 5 to 180 cc. Available both in ISO and SAE versions.

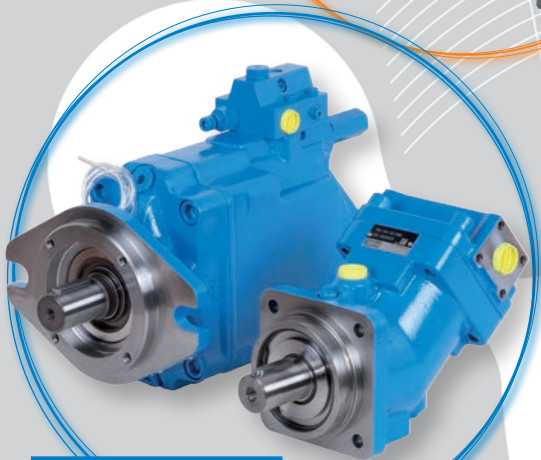
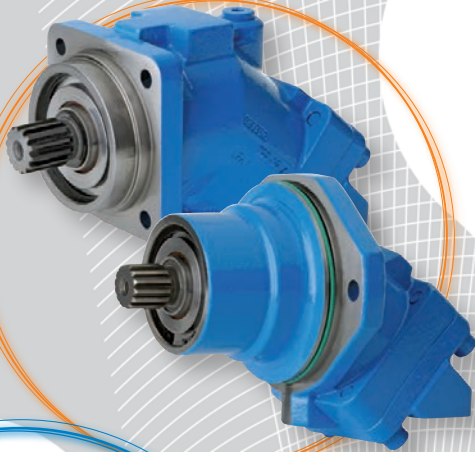

### mobile and industrial pumps

Fixed displacement pumps, the W series, and variable displacement pumps, the DELTA series. High pressure capabilities within minimal size.

**W** series: flanges to ISO 3019/2, shafts to DIN 5480.  
**DELTA** series: SAE shafts and flanges.



### hydro-pneumatic accumulators

Bladder, diaphragm accumulators.  
Spherical and cylindrical accumulators.  
Volume capacities from 20 cc to 50 liters.  
Pressures up to 500 bar.  
Accessories for use with hydraulic accumulators.

TXV

XP

PA  
PAC  
PAD

### piston pumps for trucks

HYDRO LEDUC offers 3 types of piston pumps perfectly suited to all truck and PTO-mount applications. Fixed and variable displacement from 12 to 150 cc.

### micro-hydraulics

This is a field of exceptional HYDRO LEDUC know-how:

- axial and radial piston pumps, of fixed and variable displacement,
- axial piston micro-hydraulic motors,
- micro-hydraulic units incorporating pump, electric motors, valving, controls, etc.

To users of hydraulic components which have to be housed in extremely small spaces, HYDRO LEDUC offers complete, original and reliable solutions for even the most difficult environments.



we are passionate about hydraulics...

**HYDRO LEDUC**

A dedicated R&D team means HYDRO LEDUC is able to adapt or create products to meet specific customer requirements. Working in close cooperation with the decision-making teams of its customers, HYDRO LEDUC optimizes proposals based on the specifications submitted.

**a passion for hydraulics**

### **HYDRO LEDUC**

Head office and Factory  
BP 9 - F-54122 AZERAILLES (FRANCE)  
Tél. +33 (0)3 83 76 77 40 - Fax +33 (0)3 83 75 21 58

### **HYDRO LEDUC GmbH**

Haselwander Str. 5  
D-77746 SCHUTTERWALD (GERMANY)  
Tel. +49 (0) 781-9482590 - Fax +49 (0) 781-9482592

### **HYDRO LEDUC AB**

Göteborgsvägen 74  
SE-433 02 Sävedalen (SWEDEN)  
Tel. (+46) 070 26 17 770

### **HYDRO LEDUC N.A., Inc.**

19416 Park Row - Suite 170  
HOUSTON, TEXAS 77084 (USA)  
Tel. +1 281 679 9654 - Fax +1 832 321 3553



Complete catalogues available at:  
[www.hydroleduc.com](http://www.hydroleduc.com)



HYDRO LEDUC

SAS with capital of 4 065 000 euros

Siret 319 027 421 00019

RC Nancy B 319 027 421

[mail@hydroleduc.com](mailto:mail@hydroleduc.com)

 **HYDRO  
LEDUC**  
*make it simple*