

HYDROPNEUMATIC ACCUMULATORS

DIAPHRAGM
BLADDER
BLADDER-DIAPHRAGM
PISTON

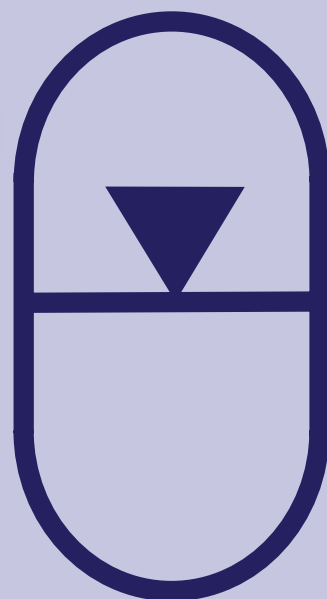

**HYDROPNEUMATIC
ACCUMULATORS**
BLADDER, DIAPHRAGM
BLADDER-DIAPHRAGM,
PISTON



Operating principle, functions and characteristics . 4

ACS(L) Welded accumulators 6

Technical description	6
Dimensions and characteristics	7
Order code system	8
Hydraulic connections	9
Gas connections	10
Accessories	11

AS Spherical accumulators 12

Technical description	12
Characteristics and dimensions	13
Order code system	14
Accessories	15

ABVE Bladder accumulators 16

Technical description	16
Characteristics and dimensions	17
Order code system	18
Accessories	19

AP(L) Piston accumulators 20

Technical description	20
Characteristics and dimensions	21
Order code system	22
Hydraulic connections	23
Gas connections	24
Accessories	25

Safety blocks 26

Pressure relief valves 28

Monitoring equipment 30

Charging equipment 33

Safety precautions & maintenance recommendations 35

The complete LEDUC product range 38

ACS(L)

- Nitrogen capacities from 0.7 to 4 litres
- Maximum pressure 330 bar depending on model
- Low temperature version: -40°C to +100°C depending on model



ACS(L) series

AS

- Nitrogen capacities from 0.02 to 10 litres
- Maximum pressure 400 bar depending on model
- Extreme operating temperatures: -20°C to +120°C



AS series

ABVE

- Nitrogen capacities from 4 to 50 litres
- Maximum pressure 330 bar depending on model
- Extreme operating temperatures: -20°C to +100°C



ABVE series

AP(L)

- Nitrogen capacities from 0.16 to 4 litres
- Maximum pressure 350 bar depending on model
- Extreme operating temperatures: -20°C to +80°C



AP(L) series

OPERATING PRINCIPLE

► Energy storage

A hydro-pneumatic accumulator is a vessel which, in hydraulic circuits, is capable of storing a large amount of energy in a small volume.

► A simple principle

If the very low compressibility of fluids makes it difficult to store their energy in small volumes, it does, however, enable them to transfer a significant force. Gas on the other hand is highly compressible, and can therefore store considerable amounts of energy in small volumes. The hydropneumatic accumulator makes use of these two properties.

- ① The hydropneumatic accumulator is a tank divided into two chambers by a flexible separator. One chamber is for fluid under pressure, the other for nitrogen gas.
- ② It is pre-charged with nitrogen to a pressure P_0 .
- ③ When a fluid travels through the accumulator, and the pressure P_1 of that fluid is higher than the pre-charge pressure P_0 of the accumulator, then the gas compresses to P_1 , the separator changes shape, and the accumulator can take in the corresponding volume of fluid.
- ④ Any pressure drop in the hydraulic circuit causes the accumulator to return fluid to the circuit, until pressure reverts to the initial P_0 .

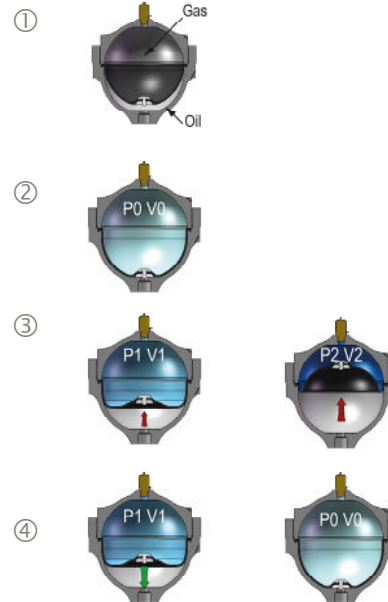

FUNCTIONS

► Surge control

The accumulator takes in the kinetic energy produced by a moving column of fluid when the circuit is suddenly shut off (valve, solenoid etc.), or more generally, when there is a sudden change in circuit pressure.

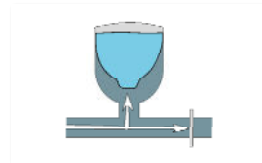

► Thermal expansion

The increase in volume due to increased temperature will be absorbed by the accumulator.

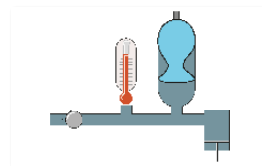

► Shock absorbing – suspension

The accumulators, in a shock absorbing function, reduce fatigue of hydraulic and mechanical components.

Examples: lifts, forklift trucks, agricultural machinery, construction equipment, etc.

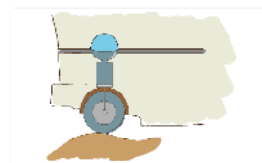

► Energy recovery and restitution

The energy supplied by a given load can be absorbed by the accumulator and put back into a hydraulic cylinder to produce a mechanical movement.

Example: closing railcar hopper doors.

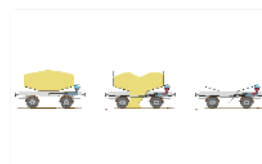

► Leak compensation

A leak in a hydraulic circuit can lead to pressure drop.

The accumulator compensates the loss in volume and thus maintains circuit pressure virtually constant.

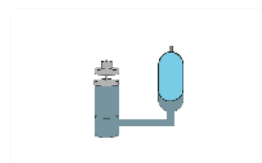

► Pulsation dampening

Adding a LEDUC accumulator to a hydraulic circuit smooths out any flow irregularities from the pumps. This leads to better operation of the system, protection of the components and thus increased service life, and reduced noise levels.

Example: dosing pumps.

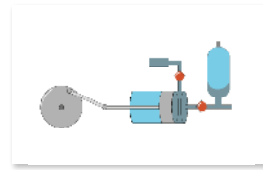

► Transfer of fluid

The LEDUC accumulator makes it possible to transfer hydraulic pressure between two incompatible fluids, via the diaphragm which separates the two fluids.

Examples:

- transfer between hydraulic fluid and sea water,
- test bench, etc.

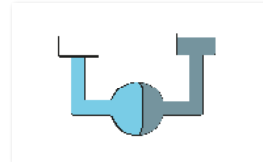

► Energy storage

In a circuit under pressure, the LEDUC accumulators allow a reserve of fluid to be kept permanently available. Thus a large amount of energy, accumulated by a low power system during periods of low or no usage, can be used in a very short time and within one cycle.

Examples:

- automatic machines,
- braking or declutching of vehicles or construction equipment
- emergency completion of working cycle in case of failure of main power source.

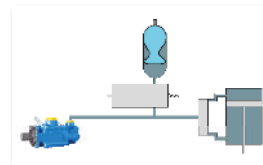

CHARACTERISTICS

Main characteristics	Diaphragm	Bladder	Bladder-diaphragm	Piston
Volumetric ratio (capacity to store a volume)	0.75	0.75	0.75	Without limit except to reach service pressure
Mounting position	For higher volumetric ratio, vertical position preferred	Vertical position	Vertical position	Any positions
Capacity for total discharge	Yes	No, except particular conditions	Yes, in particular conditions	Yes
Flow control	No	No	No	Yes
Control of the presence of fluid	No	Reduced	No	Yes (indicator possible)
Use with special fluids	Limited	Limited	Limited	Suitable (special seals)
Service life	Good	Good	Good	Very good
Resistance to contaminations	Good	Good	Good	Low
Response time	Good	Medium	Good	Low
Maintenance interval	Short	Short	Short	Long



► Technical description

The ACS(L) type welded accumulators are made up of a shell in high resistance steel containing a fluid-gas separator called a bladder-diaphragm. This bladder-diaphragm is made of nitrile for the standard range, and of hydrogenated nitrile for low temperature applications. The bladder-diaphragm is fitted with an anti-extrusion stud, thus allowing rapid and total discharge of the accumulator.

► Advantages

- Low temperature versions suitable for operation at temperatures down to -40°C (only for ACS series)
- Completely modular from 0.7 to 4 litres. This design concept means easy addition of intermediate models if required
- The bladder-diaphragm offers exceptionally good resistance to fatigue
- Rapid and total discharge possible due to the anti-extrusion stud actually fitted onto the bladder-diaphragm.

► Operating fluids

- Mineral-based hydraulic fluids.
- Other fluids: please ask.

► Examples of applications

Energy storage

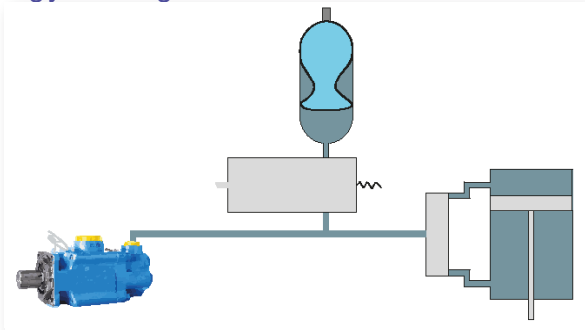

Suspension

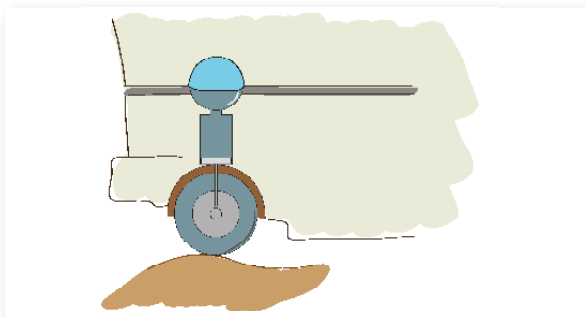

ACS 330 bar

Maximum pressure: 330 bar

Extreme operating temperatures :

- Standard version : -20°C to $+100^{\circ}\text{C}$
- Low temperature version : -40°C to $+100^{\circ}\text{C}$

ACSL 250 bar

Maximum pressure 250 bar.

Extreme operating temperatures :

- Standard version : -20°C to $+100^{\circ}\text{C}$

► Deformation of the bladder-diaphragm

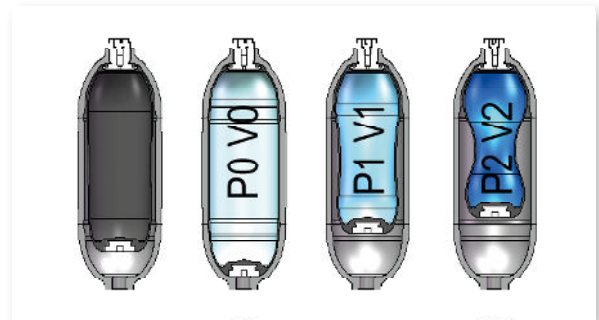

► Filling gas

Nitrogen only.

► Volumetric ratio $(V0-V2)/V0$

The recommended volumetric ratio of this type of accumulator is 0.75. For example: an ACS 4 accumulator can take in a maximum volume $0,75 V0 = 0,75 \times 4 = 3$ litres.

► Tests et certificates

Designed and certified according to the European Directive 2014/68/UE. Other certificates on request.

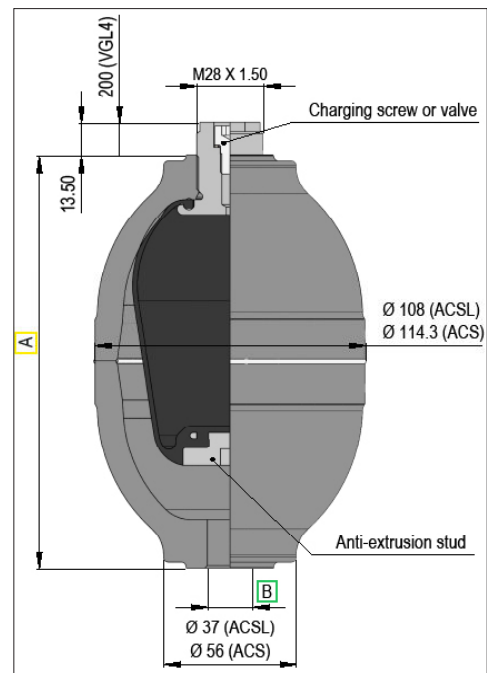
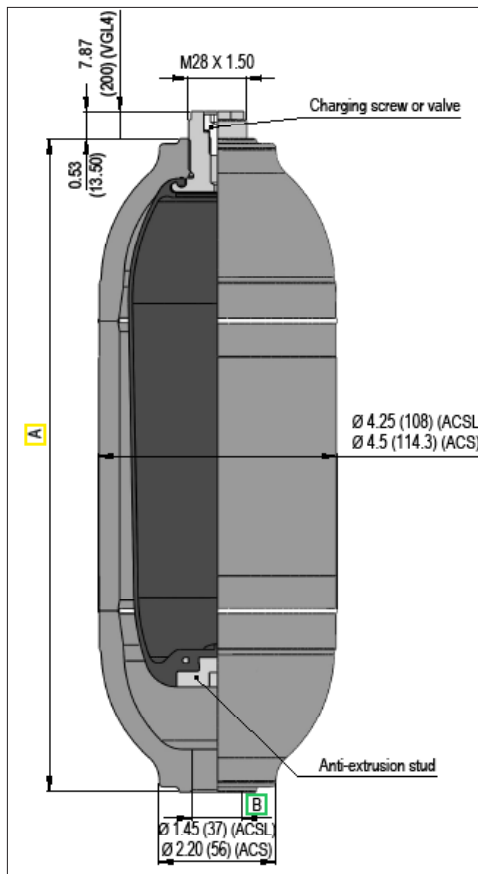

ACS(L) 0.7 L.

For **A** and **B** see the following table.

CHARACTERISTICS AND DIMENSIONS

	Volume (L)	Max. pressure (bar)	Weight (kg)	Length A (mm)	Diameter B (inches)
ACS	0.7	330	4	175	G1/2" or G3/4"
	1		5.9	236	
	1.5		7.8	315	
	2		9.9	392	
	2.5		11.5	463	G3/4"
	4		17.5	695	
ACSL	0.7	250	3	175	G1/2" or G3/4"
	1		4.5	241	
	1.5		5.9	315	
	2		7.6	392	
	2.5		8.9	463	G3/4"
	4		13.9	696	

ACS(L) Order code system

ACS(L)
01	02	03	04	05	06	07

To obtain the code of your welded cylindrical accumulator ACS(L), complete the different parameters from 01 to 07 in the table on the left according to the options you require (see table below).

Accumulator type														
		ACS	ACSL	ACS	ACSL	ACS	ACSL	ACS	ACSL	ACS	ACSL	ACS	ACSL	
01	ACS 330 bar	•		•		•		•		•		•		ACS
	ACSL 250 bar		•		•		•		•		•		•	ACSL

Volume (L)							
02		0.7	1	1.5	2	2.5	4

Operating temperature														
03	-20 +100°C	•		•		•		•		•		•		S
	-40 +100°C		•				•			•			•	F

Fluid side connections														
04	Male M33x1.5 - Female G1/2"	•		•		•		•		•		•		01
	Male M33x1.5 - Female G1/2" + M33x1.5 nut	•		•		•		•		•		•		02
	Female G1/2"	•		•		•		•		•		•		10
	Female G3/4"	•		•		•		•		•		•		11
	Female G3/8"	•		•		•		•		•		•		12
	Female M16x1.5	•		•		•		•		•		•		13
	Female M18x1.5	•		•		•		•		•		•		14
	Female 3/4"-16UNF-2B	•		•		•		•		•		•		15
	Female 1"1/16-12UNF-2B	•		•		•		•		•		•		16
Male G3/4"	•		•		•		•		•		•		50	

Gas side connections														
05	Charging screw M28 x 1.5	•	•	•		•	•	•	•	•	•	•	•	V
	P1620 valve (M16x200)	•		•		•		•		•		•		W
	SCHRADER valve (8V1)	•		•		•		•		•		•		Y

Gas side connections protection														
06	Without protection (P1620, SCHRADER) Plastic plug (M28 x 1.5 screw)	•		•		•		•		•		•		N
	With metallic plug	•		•		•		•		•		•		P

Charging pressure													
07	Specify the charging pressure (in bar).												

► Hydraulic connections - Code **04**

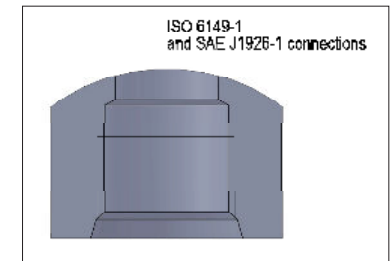
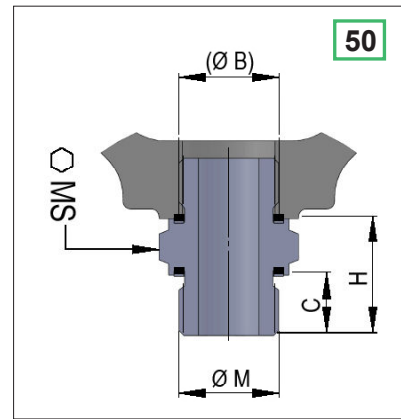
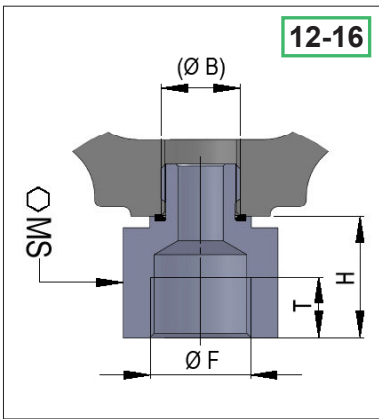
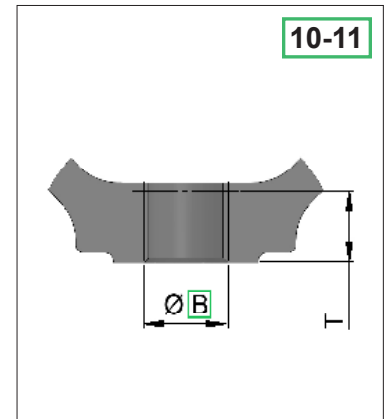
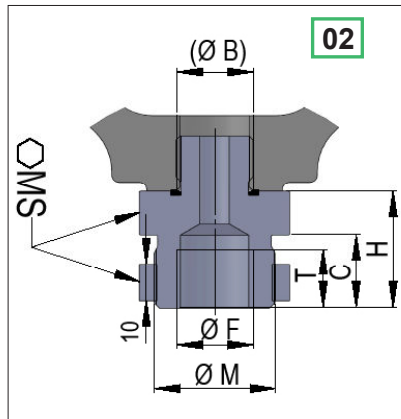
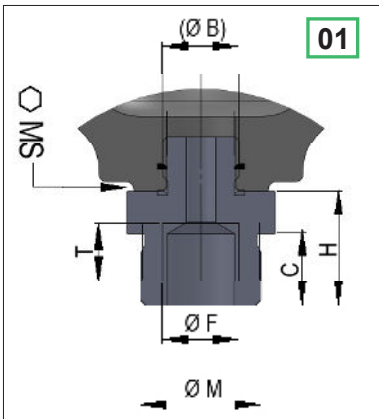

Connection for fittings : 13,15 and 16.

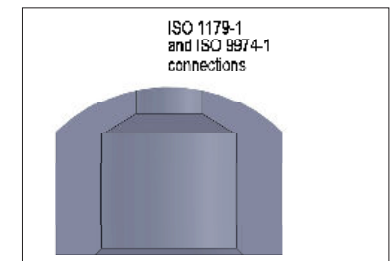

Connection for fittings : 02,01,12 and 14.

Code	Ø B	Ø F	H	SW	T useful	C	Ø M	
01	G1/2"	G1/2 - ISO 1179-1	32	41	16	20	M33x1.5	
02		without fitting	-	-	18			
10		without fitting	-	-	18			
11	G3/4"	G3/8 - ISO 1179-1	10	32	12			
12		M16x1.5 - ISO 6149-1	10	32	13			
13		M18x1.5 - ISO 9974-1	10	32	12			
14		3/4-16UNF-2B - SAE J1926-1	25	32	14.3			
15		1 1/16-12UNF-2B - SAE J1926-1	27	46	19			
16		-	-	31	32	-	16	G3/4 - DIN 3852-11
50								

Dimensions in mm.

► Gas side connections - Code **05**

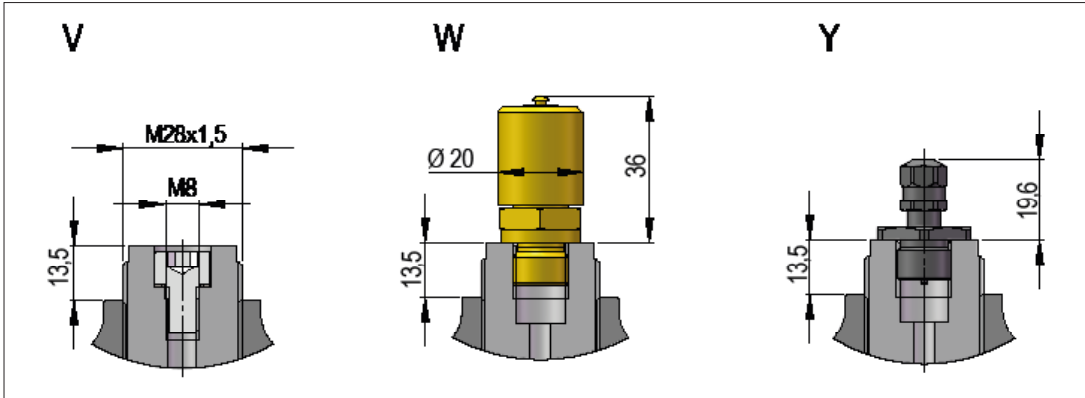

Dimensions in mm.

► Gas side options - Code **06**

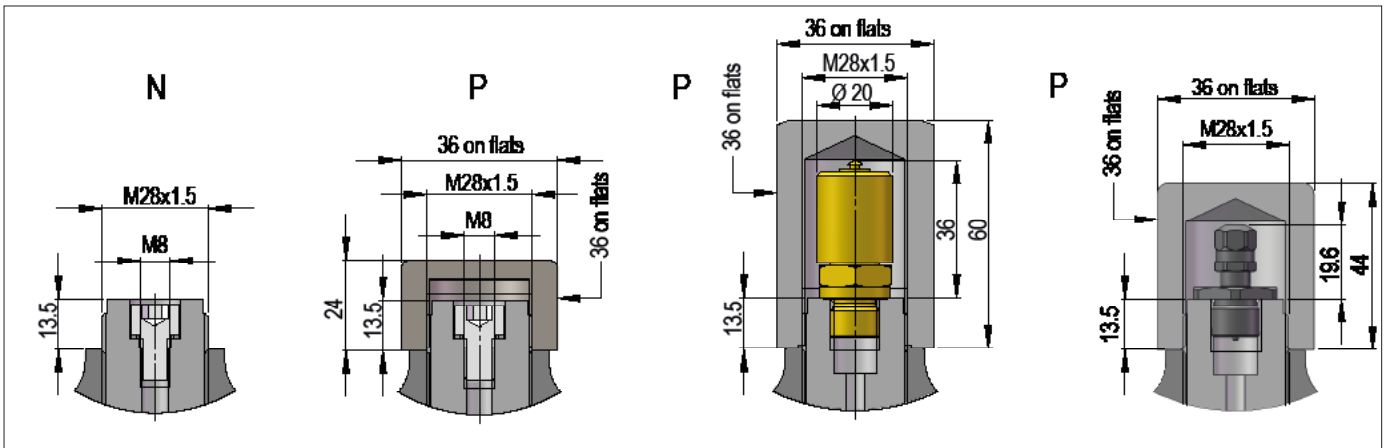

Dimensions in mm.

ACCESSORIES

► **ACS(L) adjustable clamps** ①

Volume (L)	Characteristics	Code LEDUC
0.7 - 1 - 1.5 2 - 2.5 - 4	Zinc-plated steel	254021
	Zinc-plated steel quick-tightening	254031
	Stainless steel	254032

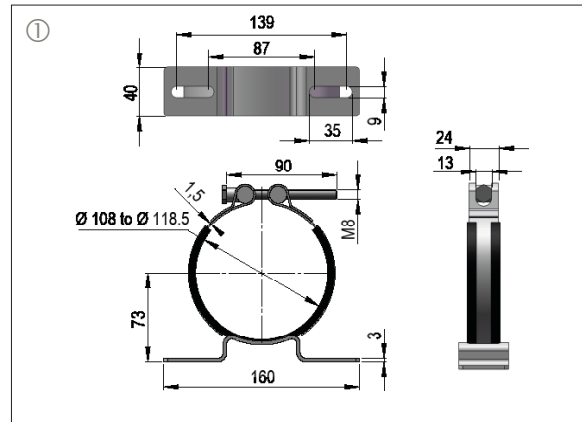

► **ACS(L) fixed clamp** ②

Volume (L)	Characteristics	Code LEDUC
0.7 - 1 - 1.5	Zinc-plated steel	C001028

Tightening torque of the fixation screws: 20 Nm.

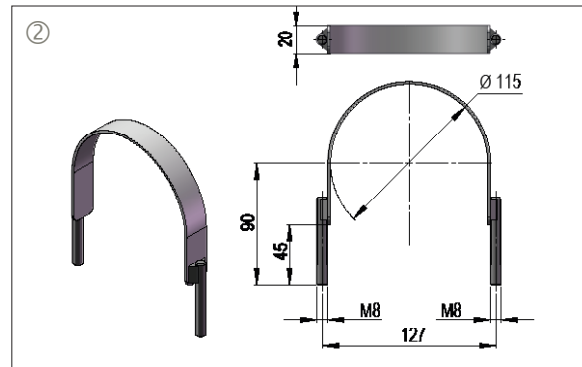

► **ACS(L) clamps** ③

Volume (L)	Characteristics	Code LEDUC
0.7 - 1 - 1.5 2 - 2.5 - 4	Zinc-plated steel	C001031
	Stainless steel	C001032

Tightening torque of the fixation screws: 20 Nm.

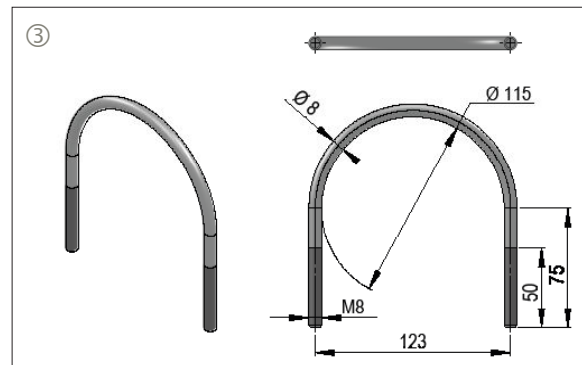



► Technical description

LEDUC spherical accumulators consist of two hemispherical shells which are screwed together and which hold a diaphragm. This diaphragm has a metal stud which closes off the operation hole when the fluid is completely discharged. There is therefore no danger of damage to the diaphragm.

The gas side port is fitted with a charging valve allowing the pressure in the accumulator to be checked or changed.

Separator:

- Standard, Nitrile: from -20°C to +100°C
- Other diaphragms are available on request.

► Advantages

The diaphragm only changes position, the elastomer in fact works little. The LEDUC spherical accumulator owes most of its qualities to its diaphragm and metal stud :

- excellent gas/fluid tightness
- possibility of total and rapid discharge
- can be adapted to suit a wide range of fluids.

► Operating fluids

- Mineral-based hydraulic fluids: standard diaphragm
- Corrosive or non-standard fluids: please consult our Customer Service Department.

► Examples of applications

Pulsation dampening

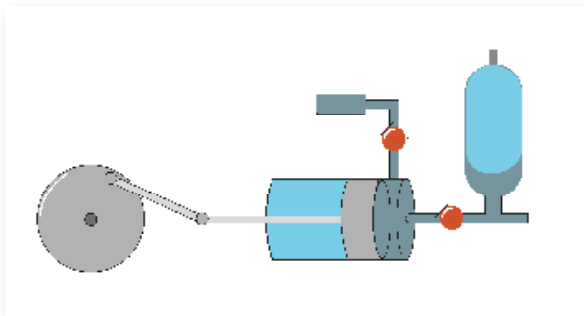

Transfer

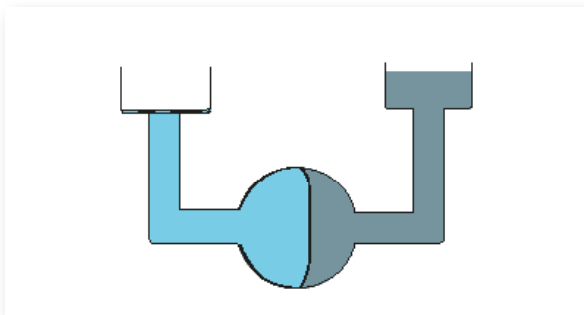

AS 400 bar

Maximum pressure : 400 bar (except for AS 0.7 L)
Extreme operating temperatures : - 20°C to + 120°C

► Deformation of the diaphragm



► Filling gas

Nitrogen only.

► Volumetric ratio(V0–V2)/V0

The volumetric ratio of this type of accumulator is 0.75.

For example: an AS 1 accumulator can take in a maximum volume of 0.75 V0:
 $0.75 V0 = 0.75 \times 1.1 = 0.82$ litres.

► Protection

On request, ARCOR® anti-corrosion treatment or paint.

► Tests and certificates

Designed and certified according to the European Directive 2014/68/UE. Other certificates on request.

► After-sales service

HYDRO LEDUC provides after sales service and supplies spare parts.

CHARACTERISTICS AND DIMENSIONS

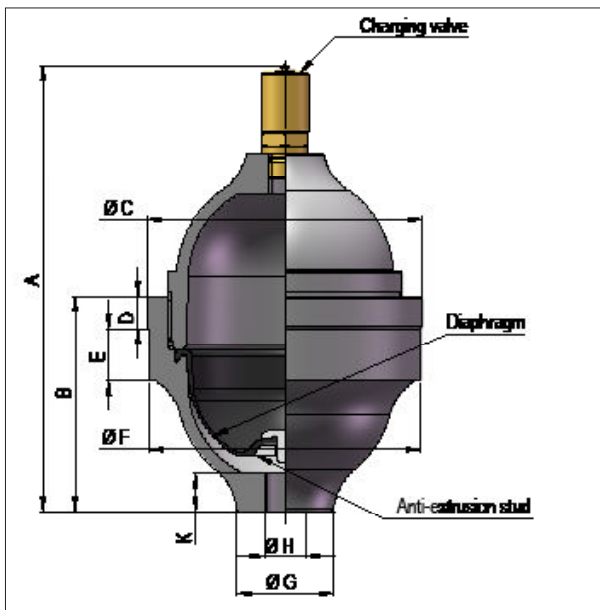

AS	Nitrogen capacity Vo (litres)	Max. pressure (bar)	Weight (kg)	Dimensions (mm)								
				A	B	Ø C	D	E	Ø F	Ø G	Ø H	K
AS 00 20	0.19	400	1.2	150	69	84.5	9	20	83.5	29	G1/4"	12
AS 00 50	0.45	400	2.8	184	89	114	12	23	112.5	40	G3/8"	16
AS 00 70	0.65	250	3	197	89	119.5	9	24	118.5	30	G3/8"	13
AS 01 00	1.1	400	5.5	197	112	163.5	50.5	50.5	163.5	40	M18 x 1.5	12
AS 02 50	2.55	400	14	251	161	213.5	37	29	210	51	G3/4"	17
AS 04 00	4.1	400	22	298	202	251	44	40	247	105	M33 x 2	20
AS 10 00	10.19	400	53	391	268	339	52.5	52.5	333	105.1	M33 x 2	20

AC	Nitrogen capacity Vo (litres)	Max. pressure (bar)	Weight (kg)	Dimensions (mm)								
				A	B	Ø C	D	E	Ø F	Ø G	Ø H	K
AC 00 02	0.017	400	0.640	See drawing below.								

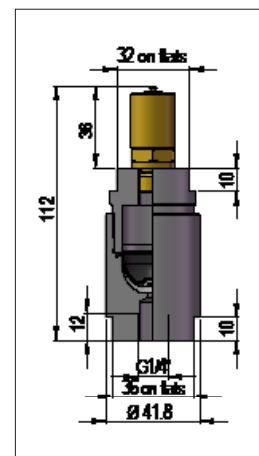

AS Spherical accumulators

To obtain the code of your AS or AC accumulator, complete the different parameters from 01 to 06 in the table on the left according to the options you require (see table below).

AS/AC					
01	02	03	04	05	06

Accumulator type										
01	Spherical accumulator		•	•	•	•	•	•	•	AS
	Compact accumulator	•								AC
Nominal size (L)										
02		0,02	0,2	0,5	0,7	1	2,5	4	10	
Shell protection										
03	Without protection	•	•	•	•	•	•	•	•	N
	ARCOR® treatment	○	○	○	○	○	○	○	○	P
Diaphragm material										
04	NBR		•	•		•	•	•	•	12R
	NBR with adherized metal stud	•	○	○	•	○	○	○	○	12A
	NBR with stainless steel stud		○	○		○	○	○	○	11R
	EPDM (epr)		○	○		○		○		31R
	FKM (Viton®)		○		○		○	○		41R
Charging valve										
05	P1620 valve (M16x200)	•	•	•	•	•	•	•	•	W
	P1620 stainless steel valve (M16x200)	○	○	○	○	○	○	○	○	X
	SCHRADER valve (8V1)	○	○	○	○	○	○	○	○	Y
Gas charging pressure										
06	Specify the charging pressure (in bar)									

- Standard version
- Special version on request.

ACCESSORIES

► Fixation clamps ①

Volume (L)	Characteritics	Code LEDUC
0.5 - 0.7	Zinc-plated steel	254021
	Zinc-plated steel quick tightening	254031
	Stainless steel	254032

Dimensions in mm.

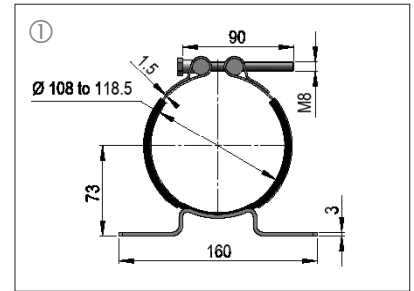

► Fixation clamps ②

Volume (L)	Dimensions (mm)			Characteritics	Code LEDUC
	Ø D	L1	L2		
1	168	184	148	Zinc-plated steel	254022
2.5	210	254	212		254006
4	247	300	248		254005

Dimensions in mm.

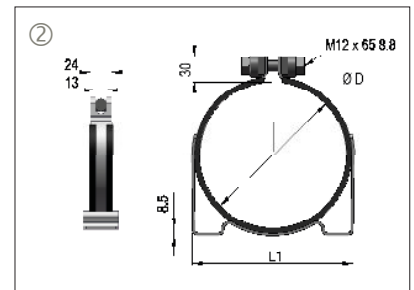

► Technical description

The ABVE bottle type accumulators consist of:

- a forged steel body
- a bladder
- a charging valve
- an oil side orifice fitted with a poppet valve which prevents extrusion of the bladder, and an air bleed screw used during system start-up.

► Advantages

Bladder accumulator component parts are interchangeable with those of major accumulators available. Dimensions allow for easy installation and also use in batteries.

► Operating fluids

- Mineral-based hydraulic fluids: standard bladder
- Non-standard and/or corrosive fluids: please consult our Customer Service Department.

► Examples of applications

Energy storage

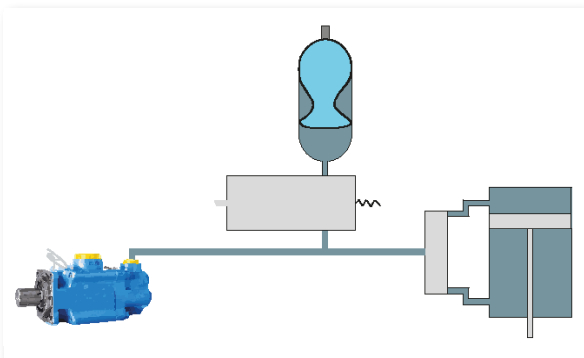

ABVE 330 bar

Maximum pressure : 330 bar
ABVE 4 maximum pressure : 350 bar

Extreme operating temperatures :

- Standard version : -20°C to +100°C



► Deformation of the bladder

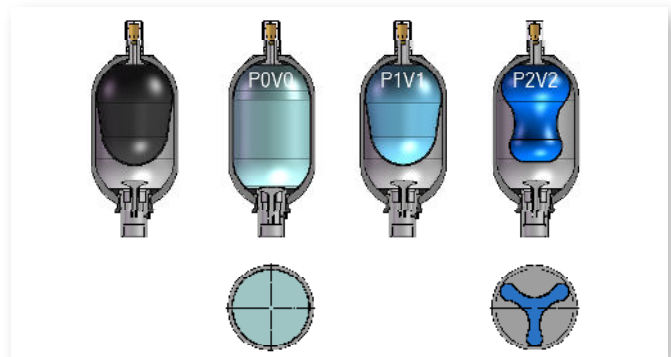

► Filling gas

Nitrogen only.

► Volumetric ratio (V0–V2)/V0

The volumetric ratio of this type of accumulator is 0.75.

For example, an ABVE 4 accumulator can take in a maximum volume of : $0.75 V_0 = 0.75 \times 3.7 = 2.8$ Litres.

► Tests et certificats

Designed and certified according to the European Directive 2014/68/UE. Other certificates on request.

HYDRO LEDUC ABVE accumulators have been qualified for 2,000,000 cycles with $\Delta P = 300$ bar.

► After-sales service

HYDRO LEDUC provides after sales service and supplies spare parts.

CHARACTERISTICS AND DIMENSIONS

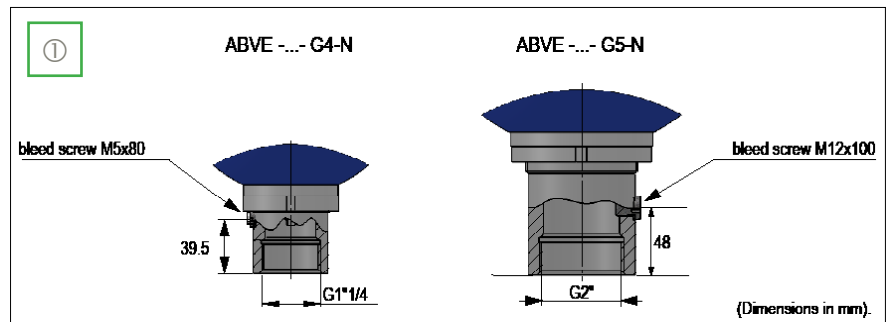
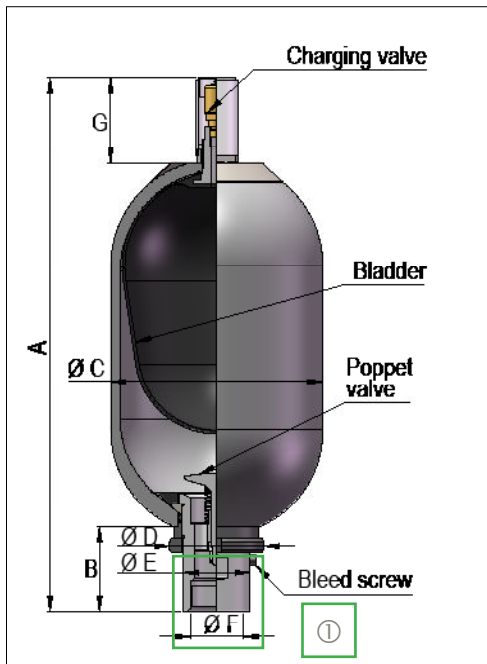

ABVE	Nitrogen capacity Vo (litres)	Max. pressure (bar)	Weight (kg)	Dimensions (mm)						
				A	B	Ø C	Ø D	Ø E	Ø F	G
ABVE 4	3.7	350	13	417.4	64	168	68	53	G1 1/4"	65.4
ABVE 10	9.6	330	32.5	575.4	102	223	101	76	G2"	65.4
ABVE 20	17.6	330	45	878.4	102	223	101	76	G2"	65.4
ABVE 32	32.7	330	80	1403.4	102	223	101	76	G2"	65.4
ABVE 50	48.9	330	110	1926	102	223	101	76	G2"	73

ABVE						
01	02	03	04	05	06	07

To obtain the code of your ABVE accumulator, complete the different parameters from 01 to 07 in the table on the left according to the options you require (see table below).

Accumulator type						
01	ABVE	<input type="checkbox"/>	<input type="checkbox"/>	<input type="checkbox"/>	<input type="checkbox"/>	ABVE
Volume (L)						
02		<input type="checkbox"/>	<input type="checkbox"/>	<input type="checkbox"/>	<input type="checkbox"/>	
		04	10	20	32	50
Gas side diameter						
03	Ø 22 mm	<input type="checkbox"/>	<input type="checkbox"/>	<input type="checkbox"/>	<input type="checkbox"/>	S2
Oil side connections						
04	G1 1/4"	<input type="checkbox"/>	<input type="checkbox"/>	<input type="checkbox"/>	<input type="checkbox"/>	G4
	G2"	<input type="checkbox"/>	<input type="checkbox"/>	<input type="checkbox"/>	<input type="checkbox"/>	G5
Gas side connections						
05	P1620 valve (M16x200)	<input type="checkbox"/>	<input type="checkbox"/>	<input type="checkbox"/>	<input type="checkbox"/>	W
	V15 valve (5/8"UNF)	<input type="checkbox"/>	<input type="checkbox"/>	<input type="checkbox"/>	<input type="checkbox"/>	T
Oil side options						
06	Without option	<input type="checkbox"/>	<input type="checkbox"/>	<input type="checkbox"/>	<input type="checkbox"/>	N
	G3/4"	<input type="checkbox"/>	<input type="checkbox"/>	<input type="checkbox"/>	<input type="checkbox"/>	A
	G2"→G1"	<input type="checkbox"/>	<input type="checkbox"/>	<input type="checkbox"/>	<input type="checkbox"/>	B
	G2»→full	<input type="checkbox"/>	<input type="checkbox"/>	<input type="checkbox"/>	<input type="checkbox"/>	C
Charging pressure						
07	Specify the charging pressure (in bar)					

ACCESSORIES

► Fixation clamps ①

Volume (L)	Dimensions (mm)			Characteristics	Code
	Ø D	L1	L2		
4	168	184	148	Zinc-plated steel	254022
10 - 20 32 - 50	221	258	216		254007

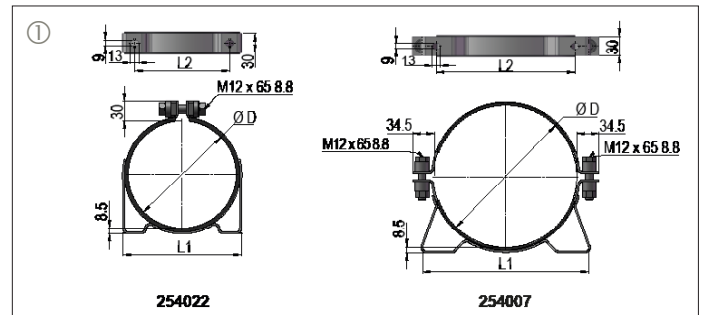

► Fixation seats ②

Volume (L)	Code LEDUC
4	254012
10 - 20 - 32 - 50	254008

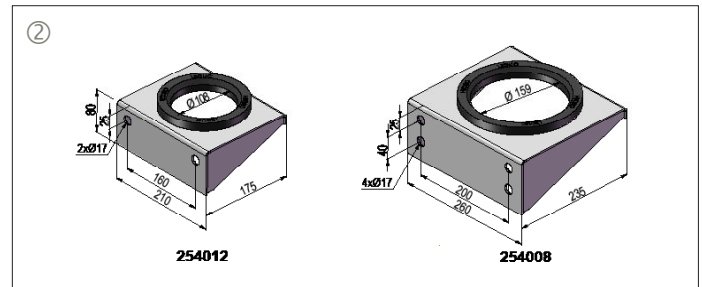

► Adaptors ③

Volume (L)	Dimensions			Characteristics	Code LEDUC
	A	B	C (mm)		
4	G1 1/4"	G3/4"	16	Steel	066305
		G3/4"	13		066074
10 - 20 - 32 - 50	G2"	G1"	19		066068
		Full	19		066069

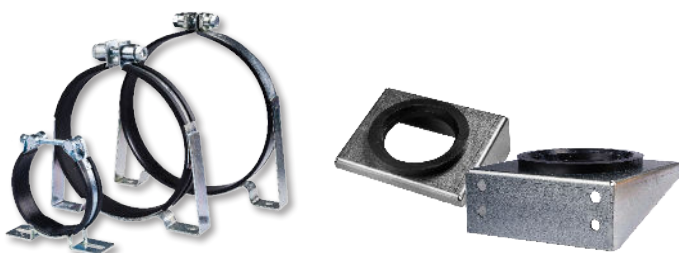
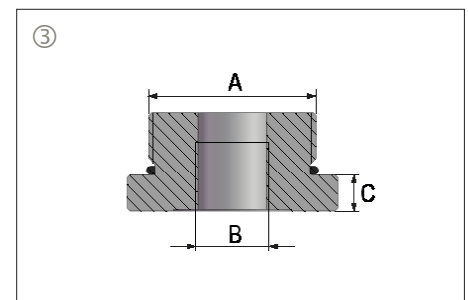

► Technical description

AP(L) accumulators are designed with a high mechanical resistance forged steel body.

The fluid-gas separating piston is equipped with seals adapted to:

- the fluids to convey
- the operating temperature.

The AP(L) accumulators can be fitted with a charging screw or charging valve, and are a modern solution for the needs of hydraulic circuits.

► Advantages

LEDUC AP(L) piston accumulators, are designed:

- to withstand very high volumetric ratios
- to ensure total and rapid discharge of fluid
- for assembly in any position
- to guarantee minimal nitrogen loss overtime
- for easy adaptation for use with different fluids and temperatures.

► Operating fluids

- Mineral-based hydraulic fluids
- Non-standard and/or corrosive fluids: please consult our Customer Service Department.

► Example of applications

Energy storage

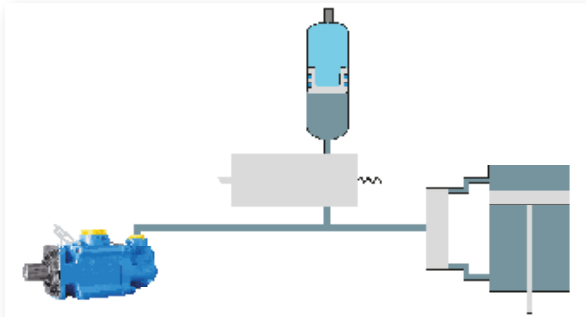

AP 350 bar

Maximum pressure: 350 bar

Extreme operating temperatures :

- Standard version: – 20°C to + 80°C
- For other temperatures, please consult us.



APL 250 bar

Maximum pressure: 250 bar

Extreme operating temperatures :

- Standard version: – 20°C à + 80°C
- For other temperatures, please consult us.

► Movement of the piston

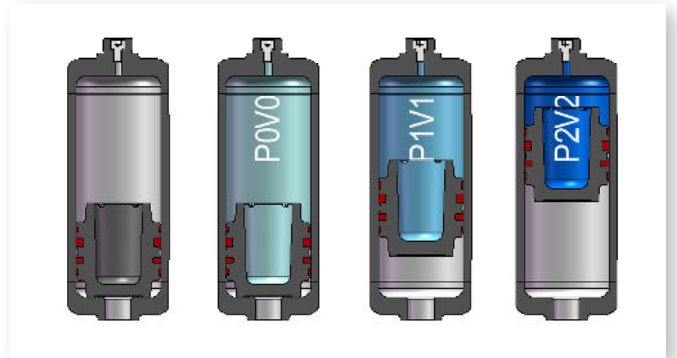

► Filling gas

Nitrogen only.

► Charging

Two versions available:

- with charging screw
- with charging valve.

For AP(L) series accumulators that are supplied pre-charged, P0 must be over 5 bar.

► Tests and certifications

Designed and certified according to the European Directive 2014/68/UE. Other certifications on request.

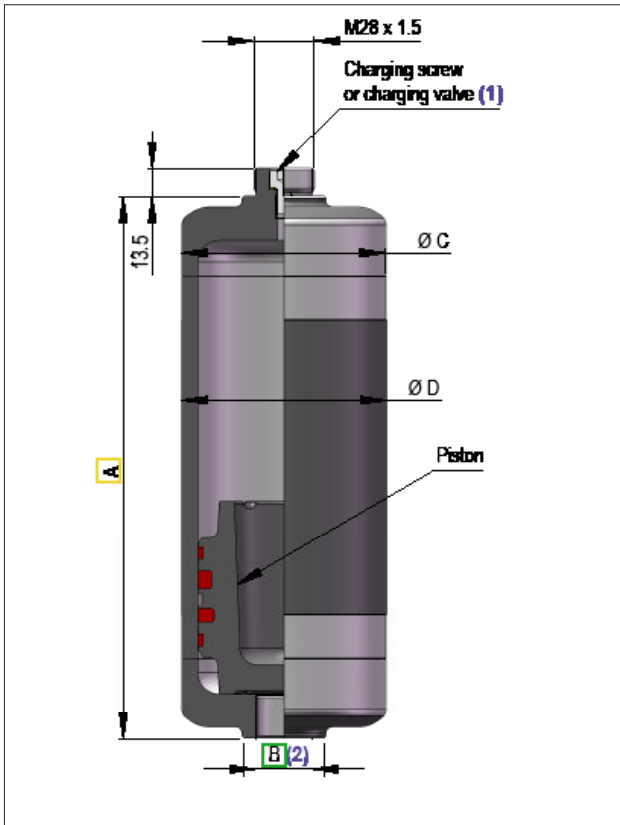

- (1) See order code system code **06** (next page)
- (2) Hydraulic connections - see order code system code **05** (next page)

CHARACTERISTICS AND DIMENSIONS

	Volume (L)	Max. pressure (bar)	A (mm)	B (inches)	Ø D (mm)	Ø C (mm)	Weight (kg)
AP	0.16	350	149.5	G1/2"	64	63.5	2.4
	0.32		231				3.2
	0.5		323				4.1
	0.75		450				6.1
	1		577				7.6
	1.25		705				9.6
	1.5		832				10.6

	Volume (L)	Max. pressure (bar)	A (mm)	B (inches)	Ø D (mm)	Ø C (mm)	Weight (kg)
APL	0.5	250	202.3	G1/2" or G3/4"	95	94.6	6.2
	0.75		252.1				7
	1		301.8				7.9
	1.5		401.3				9.5
	2		500.8				11.1
	2.5		600.2	12.8			
	3		699.7	14.4			
	3.5		799.2	16			
	4		898.6	17.6			

Dimensions in mm.

AP(L) Order code system

To obtain the code of your piston accumulator AP(L), complete the different parameters from 01 to 08 in the table on the left according to the options you require (see table below).

AP(L)																	
01	02	03	04	05	06	07	08										

Accumulator type																	
01	AP 350 bar	•	•	•		•		•		•		•					AP
	APL 250 bar				•		•		•			•	•	•	•	•	APL

Volume (L)																	
02		0.16	0.32	0.5	0.75	1	1.25	1.5	2	2.5	3	3.5	4				

Type of seal																	
03	Double sealing	•	•	•		•		•		•		•		•		•	D

Piston diameter																	
04	Ø 50 mm	•	•	•		•		•		•		•					05
	Ø 80 mm				•		•		•			•	•	•	•	•	08

Fluid side connection																	
05	Male M33x1.5 - Female G1/2"	•	•	•	•	•	•	•	•	•	•	•	•				01
	Male M33x1.5 - Female G1/2" + M33x1.5 nut	•	•	•	•	•	•	•	•	•	•	•	•				02
	Female G1/2"	•	•	•	•	•	•	•	•	•	•	•	•				10
	Female G3/4"				•		•			•	•	•	•				11
	Female G3/8"				•		•			•	•						12
	Female M16x1.5				•		•			•	•						13
	Female M18x1.5				•		•			•	•						14
	Female 3/4"-16UNF-2B				•		•			•	•	•	•	•	•	•	15
	Female 1"1/16-12UNF-2B				•		•			•	•	•	•	•	•	•	16
	Male G3/4"				•		•			•	•	•	•	•	•	•	50

Gas side connection																	
06	M28 x 1.5 screw	•	•	•	•	•	•	•	•	•	•	•	•	•	•	•	V
	P1620	•	•	•	•	•	•	•	•	•	•	•	•	•	•	•	W

Gas side options																	
07	Without protection (P1620) Plastic plug (M28 x 1.5 screw)	•	•	•	•	•	•	•	•	•	•	•	•	•	•	•	N
	With metallic plug	•	•	•	•	•	•	•	•	•	•	•	•	•	•	•	P

Charging pressure																	
08	Specify the charging pressure (in bar)																

► Hydraulic connections - Code 05

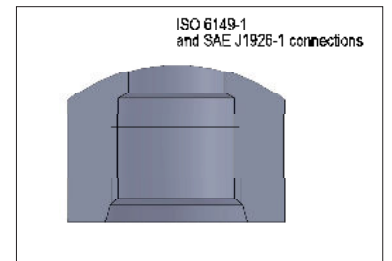
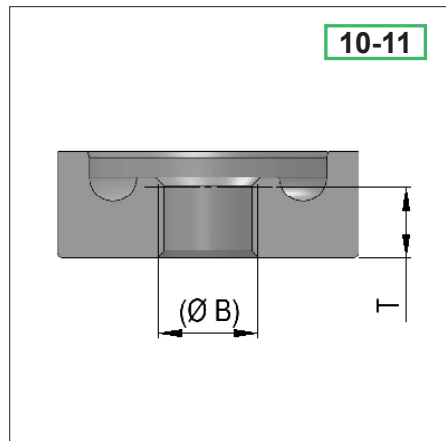
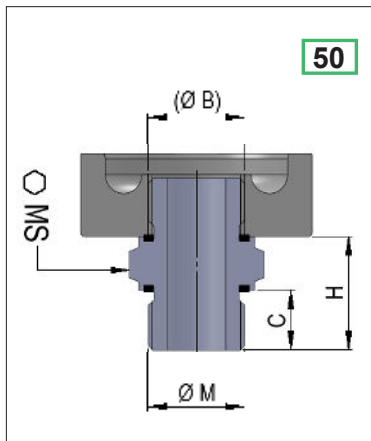
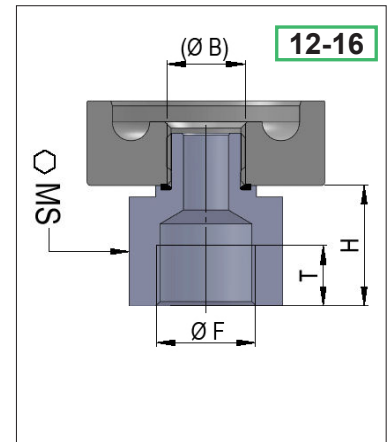
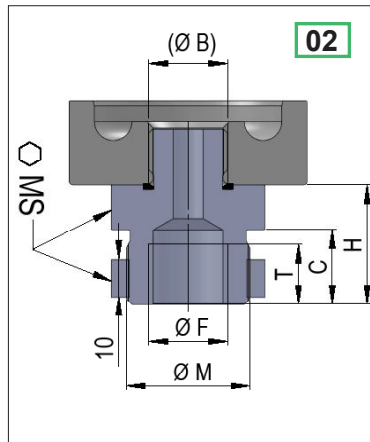
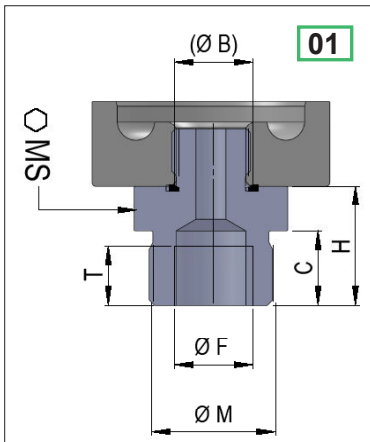

Connection for fittings : 13, 15 and 16.

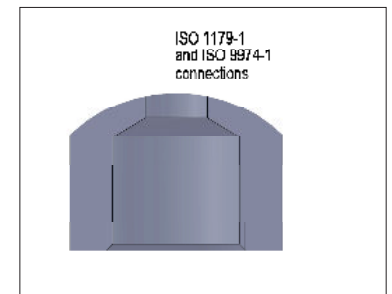

Connection for fittings : 02, 01, 12 and 14.

Code	Ø B	Ø F	H	SW	T useful	C	Ø M
01	G1/2"	G1/2 - ISO 1179-1	32	41	16	20	M33x1.5
02		without fitting	-	-	18		
10		without fitting	-	-	18		
11	G3/4"	G3/8 - ISO 1179-1	10	32	12		
12		M16x1.5 - ISO 6149-1	10	32	13	-	-
13		M18x1.5 - ISO 9974-1	10	32	12		
14		3/4-16UNF-2B - SAE J1926-1	25	32	14,3		
15		1 1/16-12UNF-2B - SAE J1926-1	27	46	19		
16							
50			-	31	32	-	16

Dimensions in mm.

► Gas side connexion - Code **06**

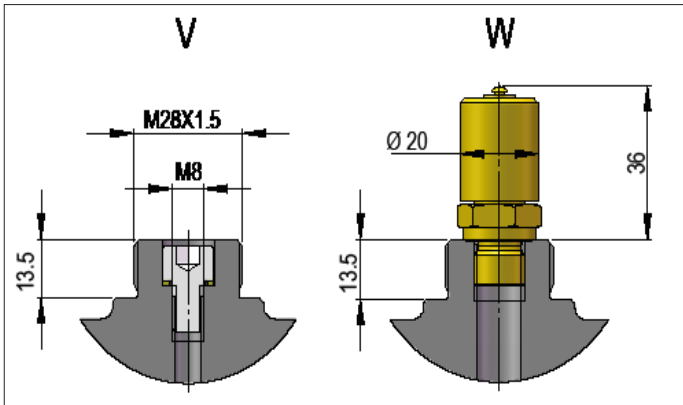

Dimensions in mm.

► Gas side connexion - Code **07**

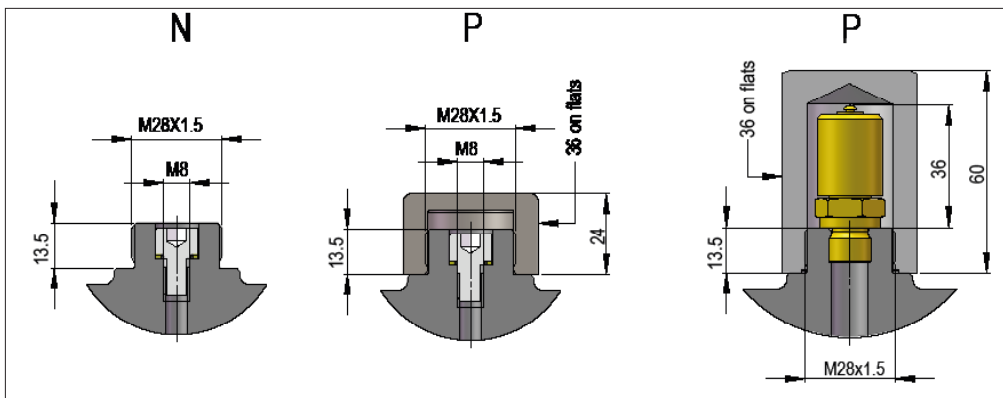

Dimensions in mm.

ACCESSORIES FOR APL

► Adjustable clamps ①

Model	Volume (L)	Dimensions (mm)							Characteristics	Code
		A	B	C	D	E	F	G		
APL	0.5 to 4	Ø 95 to 100	66	160	90	87	35	40	Zinc-plated steel	C001026
									Zinc-plated steel quick tightening	C001033
									Stainless steel	C001027
AP	0.16 to 1.5	Ø 60 to 70	40.5	120	70	85	19	50	Zinc-plated steel	C002160
									Zinc-plated steel quick tightening	C002162
									Stainless steel	C002161

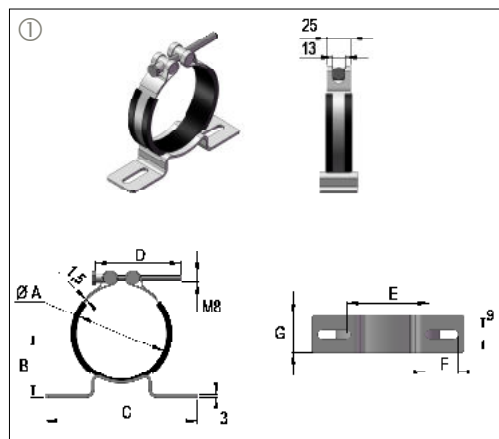

► Fixed clamps ②

Model	Volume (L)	Dimensions (mm)					Characteristics	Code
		A	B	C	D	E		
APL	0.5 to 4	100	112	70	55	35	Zinc-plated steel	C001029
							Stainless steel	C001030
AP	0.16 to 1.5	65	77	50	50	20	Zinc-plated steel	C002163
							Stainless steel	C002164

Tightening torque of the fixation screws: 20 N.m.

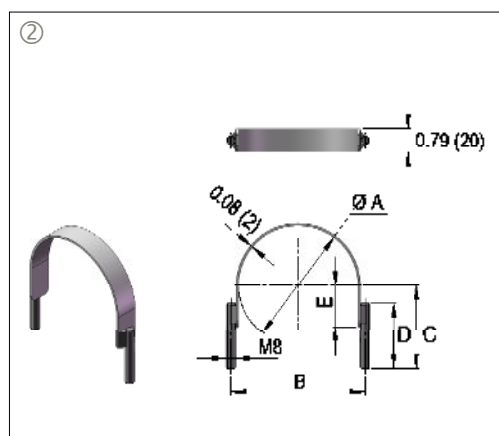

Dimensions in mm.

DESCRIPTION

These safety and shut-off blocks are designed to bring together in a single block the necessary safety organs required for the correct operation of hydraulic circuits incorporating accumulators.

The basic block consists of :

- a ball valve with quarter turn closure, to isolate the accumulator from the circuit
- needle valve ensuring the manual decompression of the circuit
- relief valve (directly operated) set at the maximum operating pressure of the accumulator. This relief valve should never be used as a limiter to protect the hydraulic pump
- the Q version is fitted with a one-way adjustable flow limiter. Mounted on the main block, this limiter controls the accumulator outlet flow, whilst inlet flow remains unrestricted.

► General technical characteristics

- nominal crossing diameter: 16 mm (BS 1 Block), 24 mm (BS 2 Block)
- maximum working pressure: 350 bar
- Temperature range : – 15°C to + 70°C
- fluid: mineral based hydraulic oil (for other fluids please contact our Customer Service department)
- flow: see pressure loss graph
- relief valve (nominal diameter): 6 mm (BS1), 10 mm (BS2)
- BS2 safety block output side connection : standard 400 bar CETOP flange
- Fitted with FKM seals.

NB : as standard, BS2 is fitted with a 2" port (accumulator side).

The safety and shut-off blocks are available in a simplified version.

They consist of a relief valve (directly operated) set at the maximum operating pressure of the accumulator. This relief valve should never be used as the limiter to protect the hydraulic pump.

► Graph of pressure drop as a function of flow

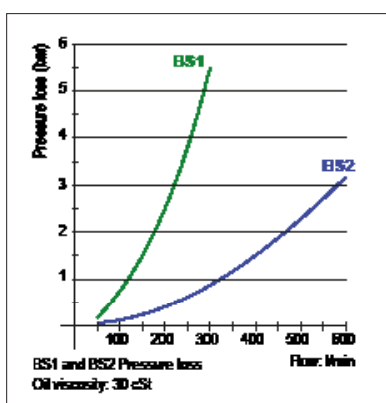

ORDER CODE

To obtain the code of your safety block, complete the different parameters from 01 to 06 in the table on the left according to the options you require (see table below).

BS					
01	02	03	04	05	06

Make your choice as a function of the possible combinations, using the columns below, and use the code in the far right-hand column.

Type				
01	Safety blocks			BS

Nominal crossing diameter				
02	DN16	•	•	1
	DN24			2

Decompression control				
03	Without control	•		N
	Manual		•	M

Flow limiter				
04	Without limiter	•	•	N

Safety relief valve setting*				
05	210 bar	•	•	210
	250 bar	•	•	250
	330 bar	•	•	330
	350 bar	•	•	350

Adapter connection				
06	Without flange	•	•	N
	G3/4"	•	•	A
	G1 1/4"	•	•	B
	G2"	•	•	C

*The pressure limiter setting is given for a flow at 50 l/min.



DIMENSIONS

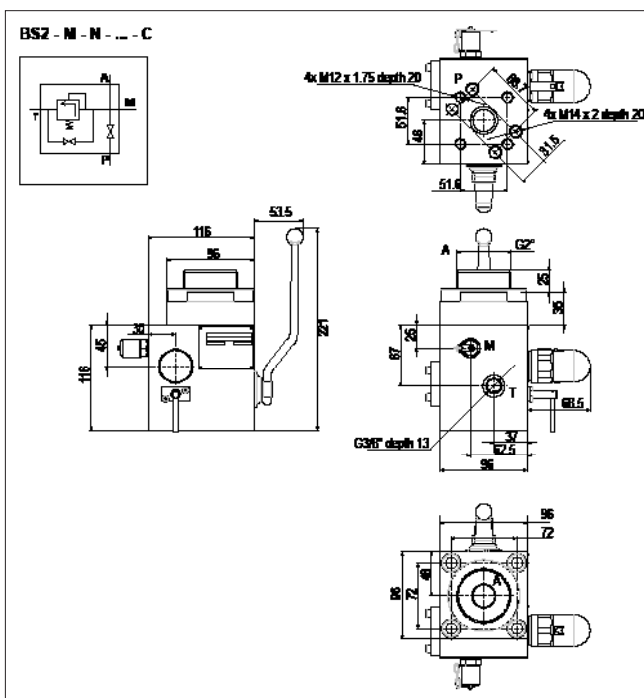
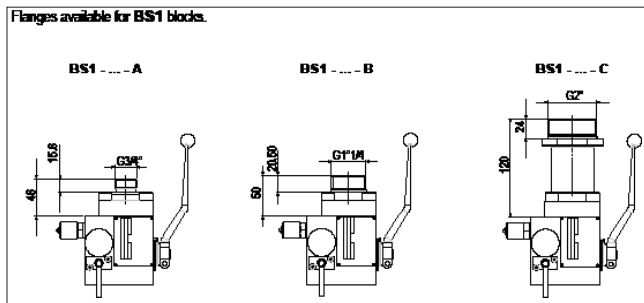
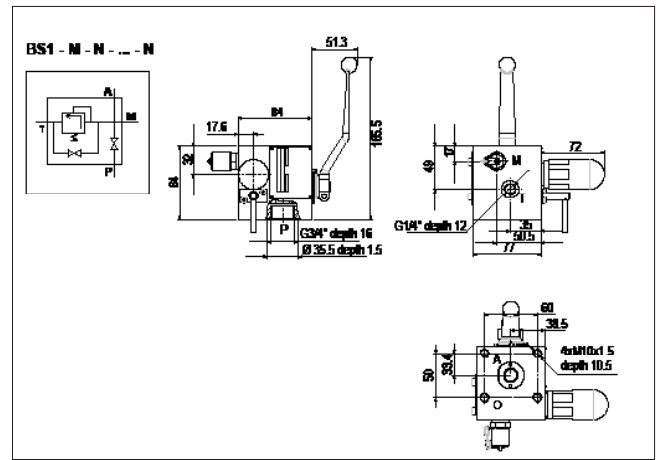
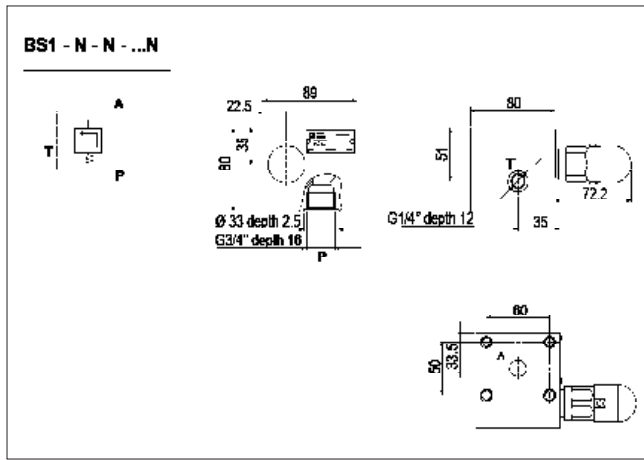



DBDS cartridges

The pressure relief valve integrated in BS1 and BS2 safety blocks (see pages 26-27) are designed to limit the maximum pressure of the circuit to ensure it cannot exceed the maximum rated pressure of the accumulator.

► General technical characteristics

Type	LEDOC code	Reference	Pressure range* (bar)	Ø D11	Tightening torque (N.m)	Weight (kg)
Size 6	DBDS 6	C001997	210	M 28 x 1.5	80	0.4
		C001998	250			
		C001999	330			
		C002000	350			
		C002001	400			
Size 10	DBDS 10	C002003	210	M 35 x 1.5	140	0.5
		C002004	250			
		C002005	330			
		C002006	350			
		C002007	400			

*The pressure limiter setting is given for a flow at 50 l/min.

Hydraulic fluid	Mineral hydraulic oil	
Required fluid cleanliness class	ISO 4406 class 20/18/15	
Nominal fluid viscosity	37 mm ² /s at 55°C	
Viscosity range	De 2.8 at 380 Cst	
Fluid temperature range (in tank)	Recommended: from 40°C to 55°C Maxi: from -20°C to +70°C	
Ambient temperature range	From -20°C to +70°C	
Max. operating pressure	DBDS 6	DBDS 10
	400 bar	630 bar
Max. pressure in T port	3 bar	

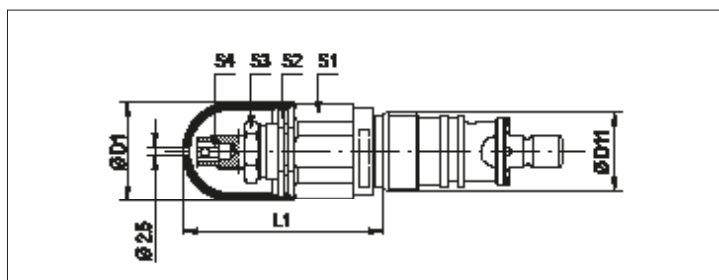

► Dimensions

Type	S1	S2	S3	S4	L1
Size 6	32	30	19	6	72
Size 10	36	30	19	6	68

These dimensions (mm) are given as an indication.

► Dimensions

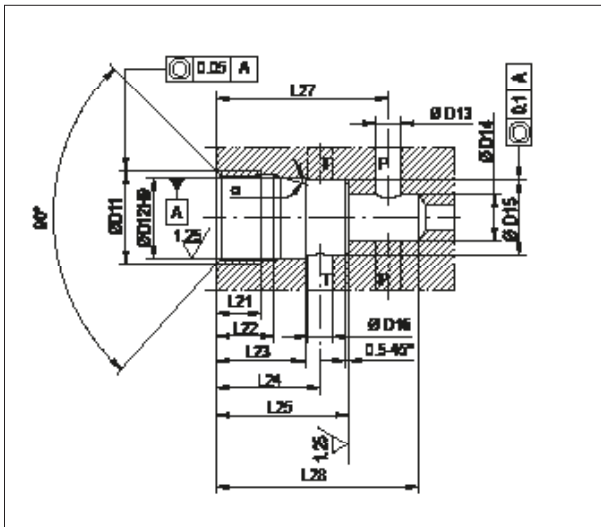

► Dimensions of the implantation of the DBDS cartridge

Type	Ø D11	Ø D12	Ø D13	Ø D14	Ø D15	Ø D16	L21	L22	L23	L24	L25	L27	L28	α
Size 6	M 28 x 1.5	25	6	15	24.9	6	15	19	30	35	45	56.5 ± 5	65	15°
Size 10	M 35 x 1.5	32	10	18.5	31.9	10	18	23	35	41	52	67.5 ± 7	80	15°

► Performance curve

Measured at:

- Viscosity $\nu = 41$ Cst
- Temperature $t = 50^\circ\text{C}$.

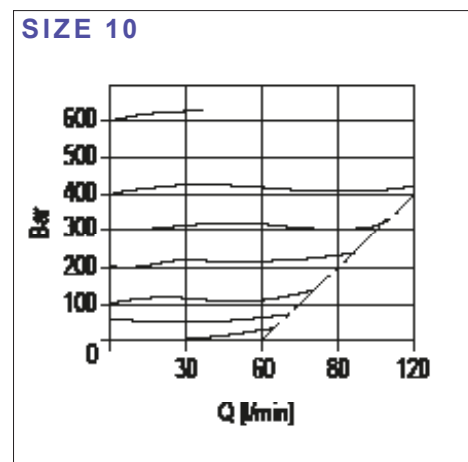
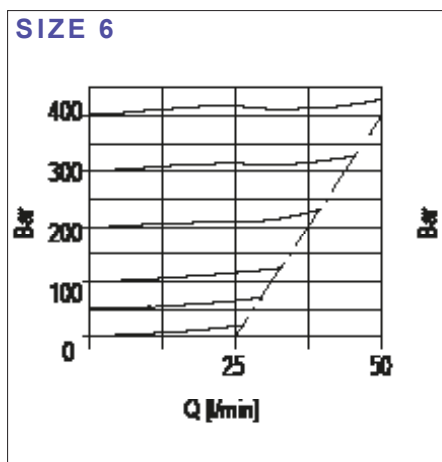

These dimensions (mm) are given as an indication.

CHARGING VALVES

The P 1620 universal valve exists in two versions:

- P 1620: standard valve, thread M 16 x 200
- PX 1620: stainless steel valve, thread M 16 x 200.

Valve type	LEDUC code	Gas side Implantation	Accumulator type	Remark	Charging device	Adapter
P1620	310367	G 1/4"	ACS-ACSL-AS-APL	Standard	VGL4	M 16 x 2.00
	310379	M 10 x 1.50	ABVE	Standard		
PX1620	310527	G 1/4"	AS	Stainless steel		
V15N	310308	M10 x 1.50	ABVE	Stainless steel		5/8" 18 UNF
Screw	066542	M8 x 1.25 with bonded seal 130331A	ACS - ACSL	Standard	VGL 4	None
Schrader	067210	G1/4	ACS-ACSL-AS-APL	Standard	VGL 4	8V1

LEDUC code	B	C on flats
310367	36	19
310379	38	17
310527	36	19

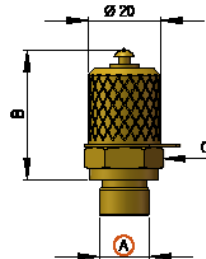

CHARGING AND GAUGING DEVICE

Reference : VGL 4 066660

Description:

The VGL 4 charging and gauging device is the essential instrument to check and to bleed the accumulator nitrogen.

The VGL 4 includes:

- a charging device VGL 4 for gas valve M 28 x 1,50
- a pressure gauge kit from 0 to 400 bar
- an adapter for connection to gas valve M 16 x 200.

Technical characteristics:

- max. pressure: 400 bar.
- pressure gauges : Ø 63 with rear connection suitable to control nitrogen pressure of accumulators fitted with P1620 valves
- scale 0 to 400 bar (or other on request) with accuracy of 1.6
- the universal charging device has a female adapter M28X1.50
- 6 mm "Allen" key.

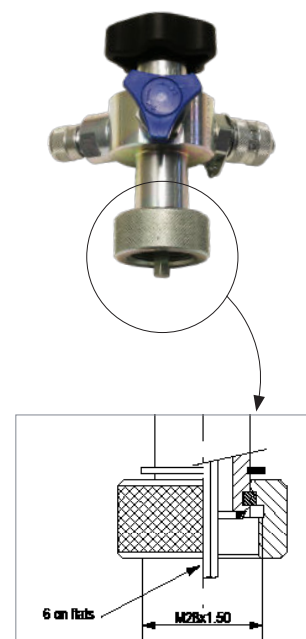

CHARGING KIT

Reference : CGLU 4F 066650

Designed to work with operating pressure up to 400 bar.

Includes:

- VGL 4 universal pressure charging and gauging device (M28 x 1.50 outlet)
- one pressure gauge from 0 to 25 bar
- one pressure gauge from 0 to 250 bar
- (additional pressure gauges on request 0-100 ; 0-400)
- adapters for connection to charging valves (M 16 x 200 - 5/8" 18UNF - G3/4" - 7/8" 14UNF - 8V1)
- 2 m-long hose, for connection to a source of nitrogen, max. pressure at 400 bar as standard (fitted with adapters for French or German bottles)
- 6 mm "Allen" key
- spare seal kit.



Precautions and maintenance

► Installing your accumulator:

Before installation, it is essential to visually check the accumulator for any external damage.

For optimal operation, the accumulator should be placed as close as possible to the application. It should be installed in a vertical position with the charging valve or screw at the top. For use in a horizontal position, please contact our Technical Department. The accumulator should be installed in an easily accessible place and be fixed using robust collars ①, a seat etc.



It is strictly forbidden to make any modification to the accumulator (welding, grinding, machining etc.), or to change the information engraved on the accumulator.

The circuit should include an isolation valve to isolate the accumulator, and also a means of checking that the hydraulic pressure never exceeds the maximum service pressure engraved on the accumulator. The accumulator must be connected to a relief valve ④ set at the accumulator's maximum authorized service pressure. All of these functions are ensured by HYDRO LEDUC safety and shut-off blocks BS1M and BS2M (see pages 26-27).

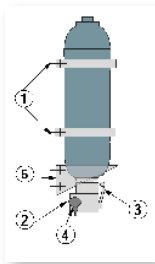

Check that the fluid is compatible with the materials used in the accumulator: the shell, elastomer, and the fluid used for the hydraulic testing. Suitable fluid : mineral-based hydraulic fluid or equivalent. For other fluids, please consult our Technical Department.

► Start up:

Accumulators are supplied either with a pre-charge pressure for storage of around 5 bar, or with pre-charge pressure as specified and corresponding to the requirement, calculated depending on working conditions. The pre-charge pressure is engraved on the accumulator shell.

Pre-charge pressure of LEDUC accumulators (all sizes) :

For all pre-charge pressures greater than or equal to 20 bar, the tolerance is $-2/+6$ bar. For a tighter tolerance, please contact our Technical Department.

All pre-charge pressures done by HYDRO LEDUC are adjusted at ambient temperature of 20°C.

- Pre-charge pressure must be checked before start-up : see the recommendations sheet supplied with each accumulator.
- Check pre-charge pressure, or charge to required pressure level, using the charging and gauging device (see also instructions supplied with the device). The influence of temperature on pre-charge pressure must be taken into consideration.
- Please note that a slight loss of nitrogen is possible when checking pre-charge pressure.



It is strictly forbidden to use any gas containing oxygen or an air compressor which would lead to danger of explosion. Use only bottled dry nitrogen.

Check that the hydraulic installation is capable of withstanding the maximum service pressure engraved on the accumulator. Check that maximum service pressure of the accumulator never exceeds the maximum service pressure engraved on the shell and on the name plate.

Volumetric ratio $((V0-V2))/V0$ must not be exceeded, see page 5.

Bleed the pipework of any air.

► Maintenance:

- Before intervening on any circuit which has a gas filled pressure vessel, the pressure must be discharged from the circuit.
- Check nitrogen pressure during the first few weeks of operation and adjust the frequency of checks depending on application.
- Ensure at every check that the accumulator has been isolated from the circuit, and that there is no more pressure on fluid side. Use the charging and gauging device VGL reference 066660 (see page 30).

Be careful to use a manometer with a measuring range compatible with the nitrogen pressure to be checked.

- Visually inspect the accumulator regularly for any signs of deterioration such as corrosion, deformation etc.
- A nondestructive testing (under using responsibility), must be made no later than when 50% of the allowable number of cycles is reached.
- For cleaning recommendations and precautions : please contact our Technical Department.
- For spare parts, only use LEDUC parts.
The user is not authorized to change any part of the accumulator without the manufacturer's prior approval. An accumulator is made up of sub-assemblies. Any modification not authorized by the manufacturer and its notified body invalidates the CE certification of the whole accumulator.

► Legislation

Hydraulic accumulators are gas pressure vessels.

The manufacture of such products must conform to European Directive 2014/68/UE.

Local regulations and legislation must be strictly respected regarding the use of accumulators.

► Pressure Equipment Directive (PED) 2014/68/EU

LEDUC accumulators up to and including 1 litre capacity are supplied with a declaration of conformity and instruction manual. They cannot be stamped CE, but conform to the Directive 2014/68/UE.

LEDUC accumulators with capacity greater than 1 litre are supplied with a declaration of conformity and instruction manual. They bear the CE stamp and the reference of the official organisation certifying their conformity.

Use of these accumulators in France is governed by decree dated 20 novembre 2017 (J.O. N°96).

► Useful addresses:

- French legislation and application of directive 2014/68/UE: <http://www.admet.com/jo>
- European legislation: <http://europa.eu.int>

Independent approved organisations: APAVE, TÜV, VERITAS...

Determine the right LEDUC accumulator for your application:
<http://toolaccumulator.hydroeduc.com/> to use our calculation program.



The LEDUC range

PISTON PUMPS FOR TRUCKS

MOBILE & INDUSTRIAL PUMPS

HYDRAULIC MOTORS



HYDRO LEDUC offers 3 types of piston pumps perfectly suited to all truck and PTO-mount applications.

- Fixed displacement from 12 to 130 cc/rev
- Fixed displacement, twin-flow, from 2x25 to 2x75 cc/rev
- Variable displacement, with LS control (load sensing) from 40 to 150 cc/rev.

The W range is composed of fixed displacement pumps, and the TXVA range, of variable displacement pumps. These pumps can operate at high pressures within minimal size.

► W and WA (SAE)* pumps:

- Fixed displac. from 12 to 180 cc/rev
- ISO 3019/2 or SAE flanges
- DIN 5480 or SAE shafts

► TXVA pumps:

- Variable displac. from 40 to 92 cc/rev
- SAE shafts and flanges.

* For SAE version, please ask.

Fixed and variable displacement piston motors

- Models from 5 to 250 cc/rev
- Available in DIN and SAE versions
- In fixed displacement, special drainless motor.



HYDROPNEUMATIC ACCUMULATORS



Diaphragm, bladder, bladder-diaphragm and piston accumulators.

Capacities from 0.02 to 50 litres

- Operating pressure up to 400 bar
- Accessories for use with hydraulic accumulators.

MICRO HYDRAULICS



This is a field of exceptional HYDRO LEDUC know-how:

- Axial and radial piston pumps, of fixed and variable displacement
- Axial piston micro-hydraulic motors
- Micro-hydraulic units incorporating pump, electric motors, valving, controls, etc.

HYDRO LEDUC offers complete, original and reliable solutions for even the most difficult environments, and within the smallest size envelopes.

A dedicated R&D team means HYDRO LEDUC is able to adapt or create products to meet specific customer requirements.

Working in close cooperation with the decision-making teams of its customers, HYDRO LEDUC optimizes proposals based on the specifications submitted.



A passion for hydraulics



HYDRO LEDUC SAS

Head Office and Factory
BP 9

F-54122 AZERAILLES

FRANCE

Tel. +33 (0)3 83 76 77 40

Fax +33 (0)3 83 75 21 58

HYDRO LEDUC GmbH

Am Ziegelplatz 20

D-77746 SCHÜTTERWALD

DEUTSCHLAND

Tel. +49 (0) 781-9482590

Fax + 49 (0) 781-9482592

HYDRO LEDUC AB

Betongvägen 11

461 38 TROLLHÄTTAN

SWEDEN

Tel. + 46 (0) 520 10 820

HYDRO LEDUC BV

Ericssonstraat 2

5121 ML RIJEN

THE NETHERLANDS

Tel. +31 6 202 40 651

HYDRO LEDUC N.A. Inc.

Grand Parkway Industrial Park

23549 Clay Road

KATY, TX 77493

USA

Tel. +1 281 679 9654



www.hydroleduc.com



HYDRO LEDUC

SAS au capital de 4 066 000 €

EORI FR31902742100019

RC Nancy B 319 027 421

contact@hydroleduc.com

EN_ACCUS_09102024